

# Pakistan Women-Centered Postabortion Care: Reference Manual



Ministry of National Health Services,  
Regulations and Coordination,  
Government of Pakistan



NATIONAL COMMITTEE FOR  
MATERNAL & NEONATAL HEALTH



2015 Edition

© 2004, 2013, 2015 Ipas.

Produced in the United States of America; printed in Pakistan. Adapted from: Ipas. (2013). *Woman-centered postabortion care: Reference manual* (second ed.) K. L. Turner & A. Huber (Eds.), Chapel Hill, NC: Ipas.

Ipas is a registered 501(c)(3) nonprofit organization. All contributions to Ipas are tax deductible to the full extent allowed by law.

Illustrations: Stephen C. Edgerton, Kwikpoint and Siddiq ul Hassan

The illustrations and photographs used in this publication are for illustrative purposes only. No similarity to any actual person, living or dead, is intended.

For more information, please contact:

Ipas Pakistan  
P.O. Box 12412  
Karachi – 75500  
Pakistan

NCMNH  
36-C, Street 14  
D.H.A Phase V  
Karachi – 75500  
Pakistan  
92-21-5341597 - 8  
info@ncmnh.org.pk  
www.ncmnh.org.pk

Ipas  
P.O. Box 9990  
Chapel Hill, NC 27515  
USA  
1-919-967-7052  
info@ipas.org  
www.ipas.org

# Foreword



As a part of its ongoing efforts to ensuring provision of high quality integrated reproductive health services at all levels of the health care delivery system in Pakistan, the Ministry of National Health Services, Regulations and Coordination is committed to provide quality technical assistance and support to all the provincial health departments for standardization and quality of trainings.

Unsafe abortion has been recognized as a major public health problem in the developing world. WHO estimates that there are approximately 22 million unsafe abortions annually, resulting in 47000 deaths and 5 million complications resulting in hospital admission. Nearly all unsafe abortions (98%) occurred in low- and middle-income countries. In Pakistan, 2.2 million abortions take place each year and almost 698,000 women were treated at health facilities for the complications due to unsafe abortions in 2012. Unsafe abortion accounts for almost 6% of maternal deaths in Pakistan.

In collaboration with Ipas Pakistan and National Committee for Maternal and Neonatal Health, the Ministry has reviewed the draft on Women-Centered Postabortion Care Reference Manual adapted from the second edition of Ipas' Woman-centered Postabortion Care: Reference Manual (2013), and hereby endorse the Reference manual for its use during the trainings of the health care professionals on safe postabortion care across the country.

The development of this training manual for training of Doctors and Midlevel Providers including Nurses, and Midwives on women-centered postabortion care is therefore a major leap towards the provision of quality and integrated RH services at all levels of health care. This manual thus aims at empowering service providers to competency manage cases of incomplete and missed abortion and deliver quality postabortion care services including postabortion family planning counseling and services, thereby ensuring optimal care of the women.

It is hoped that the use of this training manual will contribute to improving maternal health care and reducing the maternal morbidity and mortality in Pakistan.

*September 28, 2015*



Ministry of National Health Services,  
Regulations and Coordination,  
Government of Pakistan



**Dr. Assad Hafeez**  
**Director General Health,**  
**Ministry of National Health Services,**  
**Regulations and Coordination,**  
**Islamabad**

# Table of Contents

Acknowledgments.....	ii
Overview and Guiding Principles.....	1
Reproductive Rights.....	10
Community Linkages.....	23
Uterine Evacuation Methods.....	33
Monitoring to Improve Services.....	48
Informed Consent, Information and Counseling.....	61
Contraceptive Services.....	79
Infection Prevention.....	103
Clinical Assessment.....	115
Ipas MVA Instruments.....	132
Uterine Evacuation Procedure with Ipas MVA Plus.....	154
Uterine Evacuation with Misoprostol.....	190
Complications.....	206
Glossary.....	224

# Acknowledgments

This manual is based on the second edition of *Ipas' Woman-centered Postabortion Care: Reference Manual* (2013), revised by Ms. Katherine L. Turner, Ms. Amanda Huber, and Ms. Jennifer Soliman, with clinical and technical review from Dr. Alice Mark, Dr. Bill Powell, Ms. Joan Healy, Ms. Alyson Hyman, Ms. Anna de Guzman, and Ms. Nadia Shamsuddin.

The National Committee for Maternal and Neonatal Health (NCMNH) is deeply grateful to Ipas for its commitment to enhance the capacity of local partners to improve women's access to safe postabortion care services in Pakistan. We extend our sincere gratitude to Ipas for granting us permission to adapt the global curriculum according to our national context, resources and requirement.

We are grateful to Ipas staff—both in Pakistan and the United States—for their technical assistance in making this publication possible: Dr. Ghulam Shabbir, Dr. Nasira Malik, Dr. Mariam Waqas, Dr. Bill Powell, Ms. Eva Canoutas, Dr. Alice Mark, and Ms. Sara Dunbar.

In addition we sincerely thank our NCMNH-Ipas team, Dr. Ambreen Shahab, Dr. Yasmin Soomro and Dr. Erum Tanzeem for their able assistance during all stages of revision.

The national adaptation has been greatly strengthened by the support and input of our esteemed colleagues from across Pakistan. Specifically, we thank the National Technical Review Committee for reviewing and commenting on the draft changes prepared by NCMNH.

Prof. Sadiqua N. Jafarey  
Professor of Obstetrics & Gynecology,  
President NCMNH

Dr. Azra Ahsan  
Technical Consultant- NCMNH  
Technical Advisor-Ipas

*For Information please contact:*

**National Committee for Maternal & Neonatal Health**

36-C, Street 14, D.H.A Phase V,  
Karachi, Pakistan

Tel: 92-21-35341597-8

Email: [info@ncmnh.org.pk](mailto:info@ncmnh.org.pk)

Website: <http://www.ncmnh.org.pk>

## National Technical Review Committee

Dr. Anjum Afshan  
Associate Professor  
Department of Obstetrics & Gynecology  
Ziauddin Medical University  
Karachi

Prof. Aftab Munir  
Department of Obstetrics & Gynecology  
Isra University  
Hyderabad

Prof. Azizunnisa Abbasi  
Head Department of Obstetrics & Gynecology  
Ayub Medical College & Teaching Hospital  
Abbottabad

Prof. Batool Mazhar  
Chairperson MCH Centre  
Department of Obstetrics & Gynecology  
Pakistan Institute of Medical Sciences (PIMS)  
Shaheed Zulfiqar Ali Bhutto Medical  
University (SZABMU)  
Islamabad

Prof. Farrukh Zaman  
Department of Obstetrics & Gynecology  
Rashid Latif Hospital  
Lahore

Prof. Haleema Hashmi  
Professor and Academic Head  
Department of Obstetrics & Gynecology  
Liaquat National Hospital and Medical College  
Karachi

Dr. Haleema Yasmin  
Assistant Professor  
Department of Obstetrics & Gynecology  
Jinnah Postgraduate Medical Centre, (JPMC)  
Karachi

Prof. Huma Quddusi  
Professor and Head  
Department of Obstetrics & Gynecology  
Nishter Medical College  
Multan

Mrs. Imtiaz Kamal  
Secretary General- NCMNH  
Karachi

Dr. Khadija Bano  
Associate Professor  
Department of Obstetrics & Gynecology  
Jinnah Postgraduate Medical Centre (JPMC)  
Karachi

Prof. M. Tayyab  
Department of Obstetrics & Gynecology  
Allama Iqbal Medical College, Lahore  
Vice President, Society of Obstetrician and  
Gynecologists of Pakistan  
Dean Faculty of Obstetrics & Gynecology,  
College of Physician and Surgeon of Pakistan

Dr. Noreen Zafar  
Consultant Obstetrician & Gynecologist  
Provincial Coordinator Punjab, NCMNH  
Lahore

Prof. Rahat Qureshi  
Chairperson and Associate Professor  
Department of Obstetrics & Gynecology  
Aga Khan University and Hospital  
Karachi

Prof. Razia Korejo  
Department of Obstetrics & Gynecology  
Bahria Medical College  
Karachi

Dr. Rafat Jan  
President Midwifery Association of Pakistan,  
(MAP)  
Karachi

Prof. Rubina Hussain  
Chairperson and Professor  
Department of Obstetrics & Gynecology  
Ziauddin Medical University  
Karachi

Prof. Rubina Sohail  
Department of Obstetrics & Gynecology  
Allama Iqbal Medical College  
Lahore

Prof. Roshan Ara Qazi  
Department of Obstetrics & Gynecology  
Liaquat University of Medical and Health  
Sciences  
Jamshoro  
Hyderabad

Dr. Sadiya Ahsan Pal  
Consultant Obstetrician & Gynecologist  
OMI Hospital, Concept Fertility Center &  
Medicell  
Karachi

Prof. Shahida Shaikh  
Department of Obstetrics & Gynecology  
Chandka Medical College  
Shaheed Mohtarma Benazir Bhutto Medical  
University  
Larkana  
Sindh  
Member Executive Committee SOGP

Prof. Shabnum Shamim  
Department of Obstetrics & Gynecology  
Karachi Medical and Dental College (KMDC)  
Karachi

Prof. Saadiya Aziz Karim  
Chairperson  
Department of Obstetrics & Gynecology  
Karachi Medical and Dental College (KMDC)  
Karachi

Prof. Tazeen Fatima Munim  
Professor of Obstetrics & Gynecology  
Karachi Medical & Dental College (KMDC) &  
Abbasi Shaheed Hospital  
Karachi

Prof. Tasneem Ashraf  
President SOGP  
Department of Obstetrics & Gynecology  
Bolan Medical College Complex  
Quetta

# Overview and Guiding Principles

## 1.0 Introduction

Postabortion care (PAC) is a series of interventions designed to manage a woman presenting after spontaneous or induced abortion (with or without complications). It is an important

*Women-centered postabortion care is a comprehensive approach to meeting each woman's medical and psychosocial needs at the time of treatment for abortion complications.*

*Healthcare workers take into account the factors influencing a woman's need for and access to care, such as her personal circumstances and living situation. Healthcare workers provide women with respectful, confidential services, offering as many choices as possible and ensuring that women's rights to high-quality care are honored.*

component of comprehensive reproductive health services, saving women's lives and reducing morbidity.

Woman-centered PAC is a comprehensive approach which takes into account a woman's individual physical and emotional health needs and circumstances and ability to access care. It includes treatment of incomplete, missed or unsafe abortion; compassionate counseling; contraceptive services; related sexual and reproductive health services provided onsite or via referrals to accessible facilities; and community-service provider partnerships.

Based on a human rights framework, all women have the right to abortion-related

care. When referring to women's right to postabortion care, Ipas includes women of all ages, including young and unmarried women. If a provider cannot provide safe abortion-related care, he/she should refer the woman to a skilled provider.



The conditions that enable or hinder a woman's access to postabortion care determine her ability to exercise that right. These conditions include:

- A supportive legal system;
- The government and public's commitment to women's health;
- The freedom of women to exercise their sexual and reproductive rights;
- Adequate infrastructure and economic resources for the health system to serve all women in need;
- Social and cultural support of women's rights.

A woman's right to high-quality postabortion care is honored only when:

- She is provided as many choices as possible.
- She can gain access to services.
- She is offered respectful, non-stigmatizing, confidential care.

In legally-restricted settings, induced abortion should be offered for all legal indications to the fullest extent of the law.

*The number of declarations and resolutions signed by countries over the past two decades indicates a growing consensus that unsafe abortion is an important cause of maternal death that can, and should, be prevented through the promotion of sexuality education, family planning, safe abortion services to the full extent of the law, and postabortion care in all cases. The consensus also exists that postabortion care should always be provided, and that expanding access to modern contraception is critical to the prevention of unplanned pregnancy and unsafe abortion. Thus, the public health rationale for preventing unsafe abortion is clear and unambiguous. (WHO, 2012)*

*In countries where abortion is legally highly restricted, unequal access to safe abortion may result. In such contexts, abortions that meet safety requirements can become the privilege of the rich, while poor women have little choice but to resort to unsafe providers, which may cause disability and death. (WHO, 2012)*

This module provides the foundation for the curriculum. It is a recommended prerequisite for health-care providers receiving training in postabortion care and provides an introduction to the following concepts:

- postabortion care
- client rights
- provider ethics

More information on delivering care based on the concepts included in this module is in subsequent modules. For information on providing woman-centered abortion care, refer to the companion Ipas curriculum, *Woman-Centered, Comprehensive Abortion Care: Reference Manual*, Second Edition.

## 2.0 Key elements of woman-centered postabortion care

Postabortion care consists of five elements:

- *Treatment* of incomplete and unsafe abortion and abortion-related complications that are potentially life-threatening;
- *Counseling* to identify and respond to women’s emotional and physical health needs and other concerns;
- *Contraceptive and family-planning services* to help women prevent an unwanted pregnancy or practice birth spacing;
- *Reproductive and other health services* that are preferably provided onsite or via referrals to other accessible facilities in providers’ networks;
- *Community and service-provider partnerships* to prevent unwanted pregnancies and unsafe abortion, mobilize resources to help women receive appropriate and timely care for complications from abortion, and ensure health services reflect and meet community expectations and needs. (Adapted from Postabortion Care Consortium, 2002)

Each of these elements will be addressed in subsequent modules.

## 3.0 International commitment to reduce unsafe abortion

Every year, according to the WHO, millions of women have unsafe abortions performed “either by persons lacking the necessary skills or in an environment lacking the minimal medical standards or both.” Deaths and injuries from unsafe abortions continue to be a serious public health problem. Postabortion care is a response to this problem.

In 1994, at the International Conference on Population and Development (ICPD) in Cairo, governments agreed that timely life-saving treatment should be provided to women and that contraception should be made available to prevent unwanted pregnancy. Almost all countries agreed that where abortion is legal, it should be safe.

Governments later reaffirmed and built on this consensus at four global conferences:

- The 1995 Fourth World Conference on Women (FWCW) in Beijing;
- The five-year review of ICPD in 1999 (ICPD+5);
- The five-year review of FWCW in 2000;

**Spontaneous abortion:** Loss of pregnancy before fetal viability (sometimes called early pregnancy loss or miscarriage)

**Induced abortion:** Termination of pregnancy before fetal viability; can be either safe or unsafe

**Incomplete abortion:** A spontaneous or induced abortion in which some pregnancy tissue passes out of the uterus but some remains

**Missed abortion:** A spontaneous abortion in which the pregnancy ends, but the tissue remains in the uterus

- The Millennium Summit in 2000, at which the Millennium Development Goal to dramatically reduce maternal mortality was set out.

They agreed that when abortion is not against the law, health systems have an obligation to “train and equip health-service providers and [to] take other measures to ensure that such abortion is safe and accessible” (Paragraph 63iii of the ICPD+5 Conference document).

Regardless of laws and policies, all health systems are confronted with the reality of women in need of postabortion care. Women’s access to PAC is an essential part of any safe motherhood initiative. Governments and health-care workers have an ethical obligation to fulfill this right by delivering high quality, compassionate reproductive health services that include postabortion care. Timely, clinically competent postabortion care saves women’s lives. (Please see the see the Reproductive Rights module for more information on rights and policy related to postabortion care.)

#### 4.0 Woman-centered postabortion care

Woman-centered postabortion care includes a range of medical and related health services and is composed of three aims:

1. Choice
2. Access
3. Quality

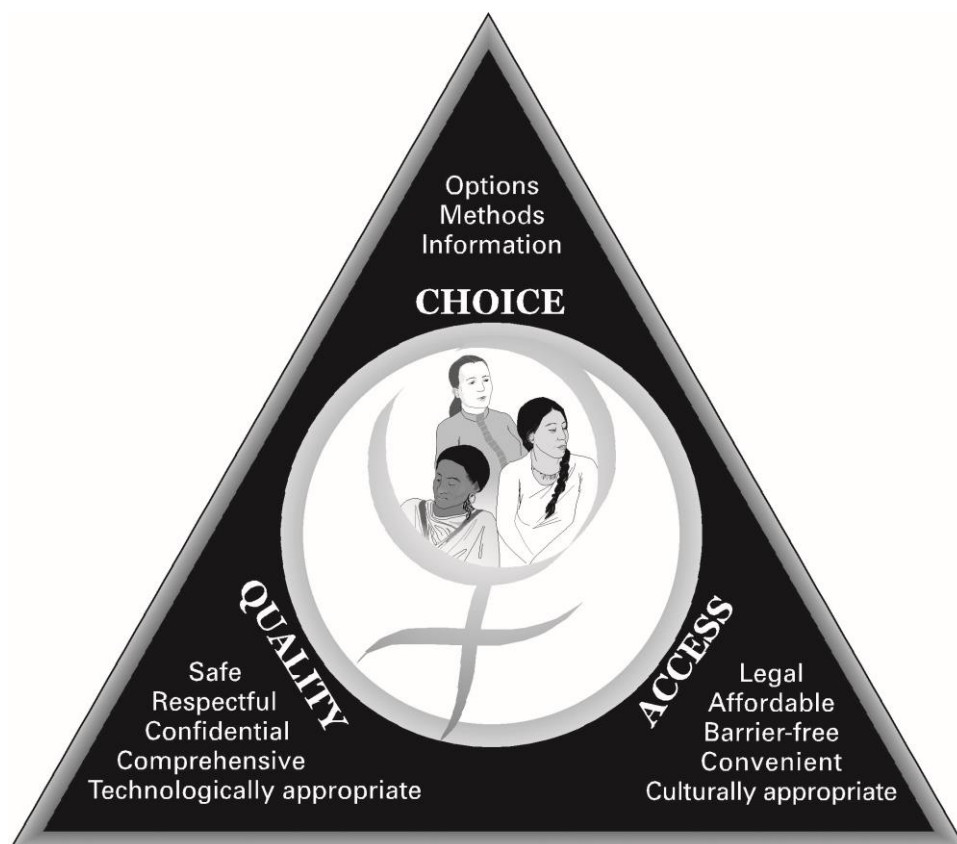

## 4.1 Choice

With regard to sexual and reproductive rights, choice means that others should not interfere with a woman's choices and decisions about her body and health. In postabortion care, choice means that it is a woman's right to:

- Determine which available postabortion care procedures, contraceptives, providers and facilities she will use;
- Be provided the means to determine if and when to become pregnant in the future;
- Obtain complete and accurate information so that she can make informed choices;
- Have the opportunity to ask questions and express concerns to providers.

To be woman-centered in their care, health workers must recognize and respond to a woman's right to choices, regardless of her age or marital status.

## 4.2 Access

A woman's access to services is determined in part by the availability of trained, technically competent providers who:

- Use appropriate clinical technologies;
- Are easily reached in local communities;
- Have many service-delivery points;
- Charge affordable fees and deliver services in a timely manner without undue logistical and administrative obstacles, and provide emergency services regardless of a woman's ability to pay;
- Display respectful, caring, empathetic attitudes;
- Do not deny services based on her economic or marital status, age, educational or social background, religious or political views, race or ethnic group or sexual preference.

Access is also influenced by cultural factors and the long-term sustainability of services.

## 4.3 Quality

Some fundamental aspects of high-quality care are:

- Tailoring care to social circumstances and individual needs;
- Providing information and counseling that supports fully informed choices, including for young women who may need more information or time to make an informed choice;
- Ensuring confidentiality, privacy, respect and positive interactions between women and staff of the health facility, regardless of age or marital status;
- Using internationally recommended medical technologies, particularly manual vacuum aspiration (MVA) and misoprostol;

- Using appropriate clinical standards and protocols for infection prevention, pain management, and managing complications;
- Providing contraceptive services and a range of contraceptive method choices at the time of postabortion services to help women prevent unwanted pregnancies and ensure healthy spacing of children;
- Providing reproductive and other health services, such as screening, diagnosis and treatment of sexually transmitted infections (STIs), including HIV, and screening and counseling for sexual violence;
- Ensuring the unique needs of young women are addressed;
- Having systems in place for monitoring adverse events;
- Having systems in place for quality improvement, including involvement from community members.

## 5.0 Upholding women's rights in a postabortion care setting

All women have the right to prompt, high-quality postabortion medical care and counseling, whether their abortion was spontaneous or induced and regardless of the legal status of the abortion. Women also have the right to information about their medical condition and to make informed decisions regarding their medical and reproductive options.

The International Planned Parenthood Federation (IPPF) has produced a formal statement declaring sexual and reproductive rights to be essential components of human rights. The 12 principles are as follows:

1. *The Right to Life.* No woman's life should be put at risk by reason of pregnancy.
2. *The Right to Liberty and Security of the Person.* No woman should be forced into pregnancy, sterilization or abortion.
3. *The Right to Equality and to Be Free from All Forms of Discrimination.* This extends to women's sexual and reproductive lives.
4. *The Right to Privacy.* All sexual and reproductive health-care services should be confidential. All women have the right to make independent reproductive choices.
5. *The Right to Freedom of Thought.* This includes freedom from the restrictive interpretation of religious beliefs and customs as tools to curtail freedom of thought on sexual and reproductive health care.
6. *The Right to Information and Education.* This includes information and education about sexual and reproductive health, access to full information, and free and informed consent.
7. *The Right to Choose Whether or Not to Marry and to Found and Plan a Family.*
8. *The Right to Decide Whether or When to Have Children.*
9. *The Right to Health Care and Health Protection.* This includes the right to the highest possible quality of care and freedom from traditional practices that are harmful to health.

10. *The Right to the Benefits of Scientific Progress.* This includes the right to new reproductive-health technologies that are safe, effective and acceptable.
11. *The Right to Freedom of Assembly and Political Participation.* This includes the right of all persons to seek to influence communities and governments to prioritize sexual and reproductive health and rights.
12. *The Right to Be Free From Torture and Ill-Treatment.* This includes the right to protection from violence, sexual exploitation and abuse.

(Adapted from International Planned Parenthood Federation, 1996)

### 5.1 Values, attitudes, empathy and respect

Health-care workers must separate their personal beliefs from their professional practices and treat all women equally, regardless of age or marital status. Health-care workers' attitudes toward women have a strong influence. Positive encounters with empathetic, respectful health-care workers heighten women's satisfaction with their care, increase their adherence to medical care instructions and make them more likely to trust health-care workers and seek appropriate medical care in the future. Positive encounters also are a foundation for good relationships between providers and the community they serve, which can create a supportive environment for their work.

### 5.2 Interaction and communication

Positive interactions and communications between health-care workers and clients are essential to high-quality medical care. It is important not to make assumptions about women seeking these services. Health-care workers need to think, speak and act as neutrally as possible, adapting their behavior and language according to cues given by each woman. This is particularly true for young women. Because abortion is a highly stigmatized area of health care, providers need to take extra measures to ensure they are not contributing to further stigmatization through their actions and words.

### 5.3 Privacy and confidentiality

It is essential that postabortion counseling and care are private and confidential.

- Managers should post confidentiality policies in client-care areas.
- Staff should explain the privacy policies to each woman.
- Administrators should establish and enforce strict confidentiality policies and procedures that apply to all health-care workers.
- Access to client information should be secured.
- Audio and visual privacy should be established before talking to or examining a woman.

### 5.4 Voluntary, informed consent

Health-care workers should not proceed with medical services until the woman has given her informed consent and signed a written consent form. All women are capable of

making the decision to seek postabortion care. In some settings, it is appropriate and common to provide witnessed verbal consent in lieu of written consent. Obtaining informed consent should not delay emergency procedures needed to save a woman's life.

## 6.0 Summary

- This module serves as the recommended prerequisite for this curriculum.
- All women, including young women, have the right to high quality postabortion care.
- Woman-centered postabortion care includes: treatment of incomplete, missed or unsafe abortion; compassionate counseling; contraceptive services; related sexual and reproductive health services provided on site or via referrals to accessible facilities; and community-service provider partnerships.
- PAC composed of five elements designed to manage incomplete abortion and ensuing complication or issues:
  - Treatment
  - Counseling
  - Contraceptive services
  - Reproductive and other health services
  - Community and service-provider partnerships
- Choice, access and quality are three key elements of woman centered postabortion care.
- Women's choices must be informed by complete and accurate information.
- Health-care workers must understand the concept of women's rights in order to conduct professional interactions and to provide compassionate, high-quality care.
- Health-care workers should exhibit empathy and respect for women and ensure privacy and confidentiality.
- Health-care workers should explain the woman's condition and options to her in non-technical language and obtain her voluntary, informed consent prior to initiating care.
- Health-care workers must be trained, technically competent, and use appropriate clinical technologies in order to provide high-quality care.

## References

- Alan Guttmacher Institute & World Health Organization. (2012). *Facts on induced abortion worldwide*. New York, NY: Alan Guttmacher Institute.
- Burns, A. A., Lovich, R., Maxwell, J., & Shapiro, K. (2012). *Where women have no doctor: A health guide for women*. Retrieved from [http://en.hesperian.org/hhg/Where\\_Women\\_Have\\_No\\_Doctor](http://en.hesperian.org/hhg/Where_Women_Have_No_Doctor).
- Cook, R. J., & Dickens, B. M. (2000). *Considerations for formulating reproductive health laws*, second edition. Geneva: World Health Organization.
- Corbett, M. R., & Turner, K. L. (2003). Essential elements of postabortion care: Origins, evolution and future directions. *International Family Planning Perspectives*, 29(3), 106-111.
- Creinin, M. D., Schwartz, J. L., Guido, R. S., & Pymar, H. C. (2001). Early pregnancy failure: Current management concepts. *Obstetrical and Gynecological Survey*, 56(2), 105-113.
- Family Health International. (1999). Client-provider interaction: Family planning counseling. *Contraceptive Technology and Reproductive Health Series*. Retrieved from <http://www.fhi360.org/sites/default/files/webpages/Modules/CPI/s1pg1.htm>
- Grimes, D. A., Benson, J., Singh, S., Romero, M., Ganatra, B., Okonofua, F.E., & Shah, I. H. (2006). Unsafe abortion: The preventable pandemic. *Lancet*, 368(9550), 1908-1919.
- Hall, J. A., Roter, D. L., & Katz, N. R. (1988). Meta-analysis of correlates of provider behavior in medical encounters. *Medical Care*, 26(7), 657-675.
- International Planned Parenthood Federation. (1996). *The IPPF charter on sexual and reproductive rights*. London, UK: International Planned Parenthood Federation.
- John, J. (1991). Improving quality through patient-provider communication. *Journal of Health Care Marketing*, 11(4), 51-60.
- Leonard, A. H., & Winkler, J. (1991). A quality of care framework for abortion care. *Advances in Abortion Care*, 1(1).
- Nations, U. (1995). *Programme of action of the fourth world conference on women*. Paper presented at the Fourth World Conference on Women, Beijing, China.
- Postabortion Care (PAC) Consortium. (2013). PAC Consortium's five essential elements of PAC. Retrieved from <http://www.pac-consortium.org/index.php/PACmodel>.
- Ipas. (2013). *Woman-centered postabortion care: Reference manual* (second ed.). K.L. Turner & A. Huber (eds.). Chapel Hill, NC: Ipas.
- United Nations. (1994, 5-13 September 1994). *Programme of Action of the United Nations International Conference on Population and Development*. Paper presented at the International Conference on Population and Development, Cairo, Egypt.
- United Nations. (1999). *Report of the Ad Hoc Committee of the Whole of the Twenty-First Special Session of the General Assembly, including key actions for the further implementation of the programme of action of the International Conference on Population and Development*. (A/S-21/5/ Add.1). New York, NY: United Nations.
- United Nations General Assembly. (2000). *United Nations Millennium Declaration*. (55/2). New York, NY: United Nations.
- United Nations Secretary-General. (2010). *Global strategy for women's and children's health*. Geneva, Switzerland: United Nations.
- Winkler, J. & Gringle, R. E. (1999). *Postabortion family planning: A two-day training curriculum guide for improving counseling and services*. Chapel Hill, NC: Ipas.
- World Health Organization (2012). *Safe abortion: Technical and policy guidance for health systems*. Geneva: World Health Organization (WHO).
- Yellen, E., & Davis, G. C. (2001). Patient satisfaction in ambulatory surgery. *Association of Operating Room Nurses (AORN) Journal*, 74(4), 483-498



# Reproductive Rights

## Key topics in this module:

- International human rights framework for postabortion care
- Barriers to postabortion services

## 1.0 Introduction

This module is designed to give an overview of the legal, policy and human rights support for the provision of postabortion care in all circumstances; and safe abortion care for all legal indications.

Several international human rights documents have addressed sexual and reproductive health. The first section of this module presents information on these documents. The second part of this module addresses obstacles that prevent women from accessing postabortion care, and presents approaches health-care providers can take to overcome those obstacles.

## 2.0 Reproductive rights

*Reproductive health is a state of complete physical, mental and social well-being and not merely the absence of disease or infirmity, in all matters relating to the reproductive system and to its functions and processes ... Reproductive rights embrace certain human rights that are already recognized in national laws, international human-rights documents and other consensus documents. These rights rest on the recognition of the basic right of all couples and individuals to decide freely and responsibly*

*the number, spacing and timing of their children and to have the information and means to do so, and the right to attain the highest standard of sexual and reproductive health. It also includes their right to make decisions concerning reproduction free of discrimination, coercion and violence, as expressed in human rights documents.*

This comprehensive definition of reproductive health and rights was agreed upon at the 1994 UN International Conference on Population and Development (ICPD). It provides a framework for legitimizing and protecting women's reproductive rights.

Specific rights that support abortion-related care include:

- The right to decide whether and when to have children (for example, women to have access to the contraceptive methods they want);
- The right to life (for example, for women not to die due to unsafe abortion);
- The right to health (for example, for women not to suffer short- and long-term injuries due to unsafe abortion);
- The right to dignity and bodily integrity (for example, for young women to be able to consent to their own uterine evacuation procedure);
- The right to freedom from discrimination (for example, because uterine evacuation is a procedure only women and not men need);
- The right to freedom from inhumane and degrading treatment (for example, this is violated when postabortion care is denied or provided in a judgmental and punitive manner);
- The right to the benefits of scientific progress (for example, the use of WHO-recommended uterine evacuation methods);
- The right to freedom of opinion and expression (for example, for people to voice their support for safe abortion care).

## 2.1 Treaties and agreements

The principles of universal human rights are set out in international conventions (also called treaties, covenants and pacts). Governments (referred to as States in the human rights systems) first indicate their agreement to uphold an international convention by signing it. The next step is to ratify the convention, which legally binds the State to enforce the convention's purposes and objectives.

Various conventions oblige governments to respect, protect, and fulfill adult and young women's sexual and reproductive rights. The following, widely ratified conventions provide the basis for women's, including young women's, sexual and reproductive rights within a human rights framework:

- The International Covenant on Civil and Political Rights (CCPR)\*
- The International Covenant on Economic, Social and Cultural Rights (CESCR) \*
- The Convention on the Elimination of All Forms of Discrimination Against Women (CEDAW)\*

- The Convention on the Rights of the Child (CRC) \*
- The Convention against Torture and Other Cruel, Inhuman or Degrading Treatment or Punishment\*
- The African Charter on Human and Peoples' Rights (ACHPR) and Its Protocol on the Rights of Women in Africa
- The American Convention on Human Rights
- The Inter-American Convention on the Prevention, Punishment and Eradication of Violence Against Women (Belém do Pará)

\* *Pakistan signatory*

Advocates can use these conventions to recommend health care policies that protect women's reproductive and sexual health.

Treaty Monitoring Committees have been established to oversee State compliance with international conventions. They issue General Recommendations and General Comments to assist States in fulfilling their obligations under a convention. (Please see Appendix A: Treaty Monitoring Committees, for more information.)

## 2.2 Global commitments

Consensus statements and declarations from international conferences convened by the UN and affiliated agencies are valuable resources for furthering women's, including young women's, sexual and reproductive health and rights. Some treaty monitoring committees use them as part of a framework for evaluating State compliance with human rights agreements.

Several landmark international conferences in the 1990s addressed women's reproductive health and safe abortion care.

- *ICPD, Cairo, 1994*. For the first time, policymakers jointly addressed unsafe abortion as a public-health concern, agreeing that timely lifesaving treatment should be provided to women and that contraception should be made available to prevent unwanted pregnancy, and calling for safe abortion in instances in which abortion is permitted by law.
- *UN Fourth World Conference on Women, Beijing, 1995*. Policymakers called on governments to "consider reviewing laws containing punitive measures against women who have undergone illegal abortions."
- *ICPD Five-Year Review (ICPD +5), 1999*. Governments reaffirmed ICPD and agreed that adequate access to services must accompany laws and policies that permit safe, legal abortion, stating that "In circumstances where abortion is not against the law, health systems should train and equip health-service providers and should take other measures to ensure that such abortion is safe and accessible. Additional measures should be taken to safeguard women's health."

States also adopt resolutions at the Human Rights Council, which is responsible for strengthening the promotion and protection of human rights around the world. Such

resolutions contain recommendations for State actions and are often relevant to work on reproductive choice.

### 2.3 Statements from policymaking bodies

Major policymaking bodies can set standards that help advance women’s reproductive rights. Although such statements are not legally binding, they convey the authority and consensus of respected health-care experts.

#### *UN agencies*

- *UN Commission on Population and Development, Report on the Forty-Fifth Session, Resolution 27, April 2012.* “Urges Governments and development partners, including through international cooperation, in order to improve maternal health, reduce maternal and child morbidity and mortality, and prevent and respond to HIV and AIDS, to strengthen health systems and ensure that they prioritize universal access to sexual and reproductive information and health-care services, including...in circumstances where abortion is not against the law, training and equipping health-service providers and other measures to ensure that such abortion is safe and accessible...”
- *WHO Safe Abortion Guidance, Second Edition 2012 (updated from 2003 edition).* “[I]n countries with highly restrictive laws on induced abortion, services may be largely limited to the treatment of complications from unsafe abortion. Such treatment is often referred to as ‘postabortion care.’ Emergency treatment of abortion complications is essential to reduce deaths and injuries from unsafe abortion.”
- *Interim Report Prepared by the UN Special Rapporteur Of The Human Rights Council on the Right of Everyone to the Enjoyment of the Highest Attainable Standard of Physical and Mental Health, 2011.* Advised that “Women are entitled to equal health protection afforded by the State as part of the right to health. Regardless of the legal status of abortion, women are entitled to receive access to goods, services and information related to sexual and reproductive health. In particular, they are entitled to have access to quality health services for the management of complications, including those arising from unsafe abortions and miscarriages. Such care must be unconditional even where the threat of criminal punishment is present, and it should not be contingent on a woman’s cooperation in any subsequent criminal prosecution, or used as evidence in any proceeding against her or the abortion providers. Laws must not require health-care personnel to report women for abortion-related care to law enforcement or judicial authorities.”
- *Essential Interventions, Commodities and Guidelines for Reproductive, Maternal, Newborn and Child Health, 2011,* jointly published by PMNCH, WHO and Aga Khan University. The publication identifies the availability and provision of postabortion care as an evidence-based intervention for reducing maternal deaths.
- *UN Global Strategy for Women’s and Children’s Health, 2010.* The strategy states that guaranteed benefits should include “safe abortion services (when abortion is not prohibited by law)” as well as emergency obstetric care and other reproductive health services.
- *Consensus for Maternal, Newborn and Child Health, 2009.* The document states that

action to improve maternal, newborn and child health can be accomplished via health systems and includes safe abortion services, when abortion is legal, and emergency obstetric care.

- *Joint and Co-Sponsored UN Programme on HIV/AIDS (UNAIDS) and the Office of the High Commissioner for Human Rights Guidelines on HIV*, 2006. These guidelines acknowledge that women with HIV/AIDS are entitled to exercise their right to access abortion-related services.
- *The Committee on the Rights of the Child*, 2003. Specifies that governments should take measures to reduce maternal morbidity and mortality in adolescent girls, particularly caused by early pregnancy and unsafe abortion practices...”
- *Making Pregnancy Safer Initiative*, 2000. One of the selected strategies is to “establish (or update) national policy and standards for family planning, induced abortion (where not against the law), maternal and newborn care (including post-abortion care), and develop a combination of regulatory measures to support these policies and standards.”
- *Millennium Development Goals*, 2000. The first target of Millennium Development Goal 5 is to reduce the maternal mortality ratio by three-quarters between 1990 and 2015. The second goal is to achieve universal access to reproductive health by 2015.

#### *Professional Associations*

- *International Federation of Gynecology and Obstetrics (FIGO) Consensus Statement On Uterine Evacuation*, 2011. The statement advises that: “Evacuate the uterus with vacuum aspiration or medications, not sharp curettage,” is an important recommendation to ensure that women have the right to the benefits of scientific progress.
- *Council of the International Confederation of Midwives*, 2008. ICM strengthened previous 1996 and 2002 position statements to ensure that a woman who seeks or requires abortion-related services is entitled to be provided with such services by midwives, including postabortion care and safe abortion according to the laws and policies of his/her country.
- *International Federation of Gynecology and Obstetrics (FIGO), Code of Ethics: FIGO Professional and Ethical Responsibilities Concerning Sexual and Reproductive Rights*, paragraph A-5, 2003 -“Conscientious objection to procedures does not absolve physicians from taking immediate steps in an emergency to ensure that the necessary treatment is given without delay.”
- Also from the *FIGO Code of Ethics*, paragraph B-4- “Assure that adolescent women are treated without age discrimination, according to their evolving capacities – rather than merely their chronological age – in facilitating them to make free and informed decisions regarding their sexual and reproductive health.”
- *Latin American Federation of Obstetric and Gynecological Societies (FLASOG)*, 2002. The Federation adopted recommendations calling on regional obstetrics and gynecology societies to broaden the indications under which abortion is legally permitted to include fetal malformation and life-threatening conditions.

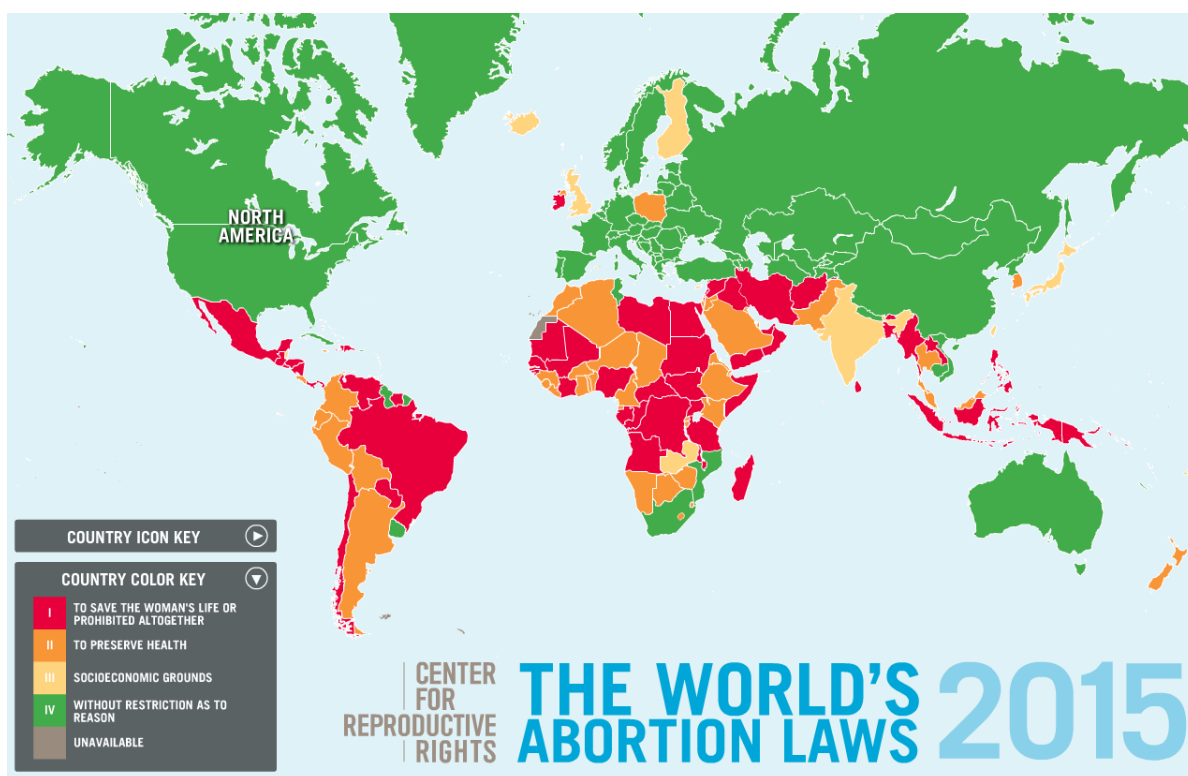

### 3.0 Barriers to delivery and access to postabortion care

Even health-care workers who do not perform clinical services have a role in ensuring that women receive high-quality PAC services. It is essential that all staff members deliver services that are based on an understanding and respect for human rights, and strive to minimize the barriers to postabortion care. Following are some of the barriers that women may face and possible actions that health systems can take to reduce barriers to postabortion care

#### 3.1 Laws, policies and practices

Some laws that affect abortion-related care have been revised or eliminated over the last several decades. Other laws remain and serve as barriers to access to abortion-related care,

#### Legal status of abortion in Pakistan

In 1990, the Pakistan Penal Code of 1860 and the Criminal Procedure Code of 1889 were amended. The purpose of the amendment was to bring the laws into conformity with the injunctions of Islam, as laid down in the Holy Quran and Sunnah.

Until 1990, the Pakistan Penal Code criminalized abortion unless it was performed in “good faith to save the woman’s life.”

Since 1997, as a result of the amendment of the Penal Code, abortion is allowed in the early stages of pregnancy, not only to “save the life of the woman,” but also to provide “necessary treatment.” This was widened legal permission for carrying out the abortion in the early stages of pregnancy, when done in “good faith.”

*Source: Patel R., Woman versus Man, Oxford Press, 2003.*

such as only authorizing physicians to perform uterine evacuation. In addition, unnecessarily narrow interpretations of existing laws and policies may lead to women being denied care or having their privacy violated.

Without clear guidance from policy and regulatory agencies such as a Ministry of Health, key stakeholders (including providers) may have difficulty knowing what they are authorized to provide under existing laws. Ministries of Health should work with medical professionals like Society of Obstetricians and Gynaecologists of Pakistan (SOGP) to develop and disseminate national clinical standards and guidelines that help ensure service delivery for abortion-related care and provide guidance on provision of induced abortion according to legal indications. If no national guidelines exist, health-care facilities should ensure that they have their own clear guidelines and protocols.

### 3.2 Restrictions that affect access

In addition to narrow interpretation of laws and policies, there are several restrictions that may affect a woman's access to postabortion care.

A few of these restrictions are:

- Lack of access to information on postabortion care services;
- Third party consent requirements (e.g., parental, guardian, spousal or judicial consent);
- Barriers to access to recommended medicines and technologies for postabortion care;
- Provider refusal to perform their professional obligation to deliver postabortion care;
- Only permitting physicians and not midlevel providers to perform postabortion care.

Even when laws or regulations do not carry restrictions, some providers will impose such restrictions, being overly cautious.

Health-care providers can work with professional associations and government or health-facility authorities to eliminate these types of restrictions. If no national policy exists regarding parental consent, health-care providers should follow the principle of the evolving capacity of the child, which states that there is no single, defined age at which a minor has the maturity and comprehension necessary to make her own decisions.

### 3.3 Provider shortages

Postabortion procedures can be accomplished competently by midlevel health professionals. Training and authorizing midwives, nurses, physician assistants and other midlevel health workers to offer all elements of postabortion care can increase access to services. This can reduce the cost and make it easier for women to obtain care closer to their homes.

### 3.4 Technological limitations

Another common barrier to safe postabortion services is the use of outdated technology,

specifically sharp curettage. This is problematic for two reasons:

- It denies women the benefits of safer and less painful methods;
- It increases the cost and complexity of services.

WHO recommends that health systems shift from using sharp curettage to vacuum aspiration or misoprostol for PAC and induced abortion services. In 2005, WHO added misoprostol to its Model List of Essential Medicines.

To ensure availability and use of recommended technologies, health-care providers can:

- Request that vacuum-aspiration equipment and misoprostol are added to their country's and facility's standard equipment lists and that procurement of supplies is handled in a timely manner;
- Commit to frequently updating their skills and encourage their colleagues to do the same;
- Train others to use newer technologies.

#### **Misoprostol in Pakistan**

*Misoprostol was registered in Pakistan for Reproductive Health indications in 2009.*

*It was included in the Essential Medicines List (EML) in 2013.*

Misoprostol for postabortion care (MPAC) has the potential to be used safely in health facilities where vacuum aspiration cannot be offered, further increasing access to postabortion care.

### 3.5 Provider attitudes and refusal of care

Health-care providers' values and beliefs about abortion-related care and the women who seek it inform their attitudes toward and interactions with women seeking postabortion care. This can affect the quality of care they deliver. Values clarification can help providers identify their values and beliefs, explore alternative values and attitudes and the consequences of their actions, learn how to separate their values from those of their clients and offer care in a way that is ethical and shows respect for a woman's rights and decisions.

Some health-care providers might be inclined to refuse to provide any abortion-related care, including postabortion care, claiming religious or moral objections. However, providers cannot refuse, or "conscientiously object" to provide postabortion care, which is considered life-saving treatment.

Health-care managers and providers should:

- Ensure that their facilities are offering postabortion care based on current standards and guidelines that are not adversely affected by the attitudes of managers and providers;
- Require that all providers offer emergency, life-saving services;
- Create a protocol that stipulates sanctions taken against providers who refuse to provide emergency care and appropriate counseling and referrals for women who are seeking induced abortion where legally indicated.



## 4.0 Providers as advocates

Some health-care providers may want to participate in broader advocacy efforts to change laws and policies that restrict women's, including young women's, reproductive rights.

Some ways to do this are:

- Partner with other advocates such as lawyers' associations and women's rights organizations to plan advocacy strategies;
- Write, publish, and encourage colleague organizations to publish statements recognizing reproductive rights as human rights or stating their support for access to postabortion care;
- Work with policymakers to take an active role in defining current laws and policies;
- Educate policymakers and others by disseminating statistics on abortion-related maternal mortality and morbidity;
- Connect with community-based advocacy efforts that demand postabortion care services, improved access to contraception, and/or sexual and reproductive health education for women, particularly young women.

## 5.0 Summary

- International treaties, conventions, consensus statements and declarations can help protect reproductive rights.
- Treaty Monitoring Committees exist to monitor State compliance with international conventions.
- Consensus statements, declarations and commitments provide an important basis for upholding women's and young women's sexual and reproductive health and rights.
- Statements by UN agencies and associations of health-care providers and policymakers can help set standards that can advance women's and young women's reproductive rights.
- Numerous statements, declarations and commitments by many international bodies, including the UN, support the provision of postabortion care.
- Postabortion care is sometimes subject to restrictions that impede many women's, including young women's, access to services.
- Provider attitudes have a significant impact on women's access to postabortion care and the quality of care.

## References

- Alan Guttmacher Institute. (1999). *Sharing responsibility: Women, society & abortion worldwide*. New York, NY: The Alan Guttmacher Institute.
- Association of Reproductive Health Professionals. (2012). Position Statements. Retrieved from <http://www.arhp.org/About-Us/Position-Statements>.
- Center for Reproductive Law and Policy, & Groupe de recherche femmes et lois au Senegal. (1999). *Women of the world: Laws and policies affecting their reproductive lives: Francophone Africa*. New York, NY: Center for Reproductive Law and Policy.
- Center for Reproductive Rights. (2006). *Bringing rights to bear: An Advocate's Guide to the Work of UN Treaty Monitoring Bodies on Reproductive and Sexual Rights*. New York, NY: Center for Reproductive Rights.
- Cook, R. J., & Dickens, B. M. (2000). *Considerations for formulating reproductive health laws*, second edition. Geneva: World Health Organization.
- International Confederation of Midwives. (2008). *Midwives' provision of abortion-related services*. The Hague, Netherlands: International Confederation of Midwives.
- International Federation of Gynecology and Obstetrics. (2011). *Consensus statement on uterine evacuation* (pp. 2). London, UK: International Federation of Gynecology and Obstetrics.
- Ipas. (2002). *Human rights, unwanted pregnancy, and abortion-related care: Reference information and illustrative cases*. M. de Bruyn (Ed.) Chapel Hill, NC: Ipas.
- Ipas, & Karolinska Institute: Division of International Health. (2002). *Deciding women's lives are worth saving: Expanding the role of midlevel providers in safe abortion care*. (Vol. 7). Chapel Hill, NC: Ipas.
- Joint United Nations Programme on HIV/AIDS (UNAIDS). (2011). *Community innovation: Achieving sexual and reproductive health and rights for women and girls through the HIV response*. Geneva, Switzerland: Joint United Nations Programme on HIV/AIDS (UNAIDS).
- Latin American Federation of Obstetric and Gynecological Societies (FLASOG). (2002). *Recommendations of the General Assembly, 17th Congress*. Paper presented at the XVII FLASOG Latin American Congress of Obstetrics and Gynaecology, Santa Cruz, Bolivia.
- Lichter, D. T., McLaughlin, D. K., & Ribar, D. C. (1998). State abortion policy, geographic access to abortion providers and changing family formation. *Family Planning Perspectives*, 30(6), 281-287.
- Office of the High Commissioner for Human Rights (OHCHR). (2013). United Nations Human Rights Council: Background information on the Human Rights Council. Retrieved September 2012, from <http://www.ohchr.org/EN/HRBodies/HRC/Pages/AboutCouncil.aspx>.
- Office of the United Nations High Commissioner for Human Rights, & Joint United Nations Programme on HIV/AIDS (UNAIDS). (2006). *International guidelines on HIV/AIDS and human rights, 2006 consolidated version*. Geneva, Switzerland: Joint United Nations Programme on HIV/AIDS (UNAIDS).
- Office of the United Nations High Commissioner for Human Rights and the Joint United Nations Programme on HIV/AIDS. (1998). *HIV/AIDS and human rights: International guidelines*. Paper presented at the Second International Consultation on HIV/AIDS and Human Rights, Geneva, Switzerland.
- Otsea, K., Baird, T. L., Billings, D. L., & Taylor, J. E. (1997). *Midwives deliver postabortion care services in Ghana*. Carrboro, NC: Ipas.
- Partnership for Maternal, Newborn and Child Health (2009). *Consensus for maternal, newborn and child health*. Geneva, Switzerland: Partnership for Maternal, Newborn & Child Health.
- Renner, R. M., Nichols, M. D., Jensen, J. T., Li, H., & Edelman, A. B. (2012). Paracervical block for pain control in first-trimester surgical abortion: a randomized controlled trial. *Obstetrics & Gynecology*, 119(5), 1030-1037.
- Starrs, A. (1997). The Safe Motherhood action agenda: Priorities for the next decade. *Proceedings of the Safe Motherhood Technical Consultation, 18-23 Oct. 1997, Colombo, Sri Lanka*. New York, NY: Inter-Agency Group for Safe Motherhood.

- The Partnership for Maternal Newborn & Child Health (PMNCH), World Health Organization (WHO), & Aga Khan University. (2011). *Essential interventions, commodities and guidelines for reproductive, maternal, newborn and child health: A global review of the key interventions related to reproductive, maternal, newborn and child health*. Geneva, Switzerland: World Health Organization.
- Turner, K. L., & Page, K. C. (2008). *Abortion attitude transformation: A values clarification toolkit for global audiences*. Chapel Hill, NC: Ipas.
- Turner, K. L., Weiss, E., & Gulati-Partee, G. (2009). *Providers as advocates for safe abortion care: A training manual*. Chapel Hill, NC: Ipas.
- UN Women. (2011). *In pursuit of justice: 2011-2012 progress of the world's women*. New York, NY: UN Women.
- United Nations. (1994, 5-13 September 1994). *Programme of Action of the United Nations International Conference on Population and Development*. Paper presented at the International Conference on Population and Development, Cairo, Egypt.
- United Nations. (1995). *Programme of Action of the Fourth World Conference on Women*. Paper presented at the Fourth World Conference on Women, Beijing, China.
- United Nations. (1999). *Report of the Ad Hoc Committee of the Whole of the Twenty-First Special Session of the General Assembly, including key actions for the further implementation of the programme of action of the International Conference on Population and Development*. (A/S-21/5/Add.1). New York, NY: United Nations.
- United Nations Commission on Population and Development. (2012). *Report on the forty-fifth session, resolution 27*. New York, NY: United Nations.
- United Nations Committee on the Rights of the Child. (2003). *General comment No. 4: Adolescent health and development in the context of the Convention on the Rights of the Child*. (CRC/GC/2003/4). New York, NY: United Nations.
- United Nations General Assembly. (1966). *The international covenant on economic, social and cultural rights*. New York and Geneva: United Nations General Assembly.
- United Nations General Assembly. (1989). *Convention on the rights of the child*. New York and Geneva: United Nations General Assembly.
- United Nations General Assembly. (2000). *United National Millennium Declaration*. (55/2). New York, NY: United Nations.
- United Nations Human Rights Council. (2011). *Interim report prepared by the Special Rapporteur of the Human Rights Council on the right of everyone to the enjoyment of the highest attainable standard of physical and mental health*. New York, NY: United Nations.
- United Nations Secretary-General. (2010). *Global strategy for women's and children's health*. Geneva: United Nations.
- World Health Organization. (2005). *WHO Model List of Essential Medicines*. (EML14). Geneva: World Health Organization.
- World Health Organization. (2012). *Safe abortion: Technical and policy guidance for health systems*. Geneva: World Health Organization.
- World Health Organization, John Snow Inc., International Planned Parenthood Federation, PATH, Population Action International, United Nations Population Fund, & World Bank. (2006). *Interagency Guidelines: Inter-agency list of essential medicines for reproductive health*. Geneva: World Health Organization.
- World Health Organization Executive Board 107th session. (2000). *Making pregnancy safer: Report by the Secretariat*. Geneva: World Health Organization.
- World Health Organization (WHO). (2000). *Pregnancy and HIV/AIDS. Fact Sheet No. 250, June 2000*.

## Appendix A: Treaty Monitoring Committees

Treaty Monitoring Committees have been established to oversee State compliance with international conventions. They issue General Recommendations and General Comments to assist States in fulfilling their obligations under a convention. For example, the Committee on the Rights of the Child has urged States: “(a) to develop and implement programmes that provide access to sexual and reproductive health services, including family planning, contraception and safe abortion services where abortion is not against the law.”

During the monitoring process:

- States submit regular reports, summarizing the actions they have taken toward compliance and identifying measures that are still needed;
- Individuals and organizations submit “shadow reports or letters,” providing the Committees with their own findings on State compliance;
- Committees make recommendations on how a State can improve compliance.

States are not legally obliged to carry out these recommendations but are expected to do so. Advocates can use those recommendations to hold governments accountable for making changes in laws and practices that uphold women’s sexual and reproductive rights. Some conventions also have Optional Protocols, which enable individuals and organizations to present complaints about human rights violations. For example, the CEDAW Committee has received complaints related to abortion and asked States to make legal abortion accessible to all women without delay.

Seven international human rights conventions have Treaty Monitoring Committees that monitor implementation of the conventions by the States that have ratified them. They are:

1. Committee on the Elimination of Discrimination Against Women (CEDAW) – Convention on the Elimination of All Forms of Discrimination Against Women, [www2.ohchr.org/english/bodies/cedaw/cedaws40.htm](http://www2.ohchr.org/english/bodies/cedaw/cedaws40.htm)
2. Committee on the Rights of the Child – Convention on the Rights of the Child, [www2.ohchr.org/english/bodies/crc/](http://www2.ohchr.org/english/bodies/crc/)
3. Committee Against Torture – Convention Against Torture and Other Cruel, Inhuman or Degrading Treatment or Punishment, [www2.ohchr.org/english/bodies/cat/](http://www2.ohchr.org/english/bodies/cat/)
4. Human Rights Committee – International Covenant on Civil and Political Rights, [www2.ohchr.org/english/bodies/hrc/index.htm](http://www2.ohchr.org/english/bodies/hrc/index.htm)
5. Committee on the Elimination of Racial Discrimination – International Convention on the Elimination of All Forms of Racial Discrimination, [www2.ohchr.org/english/bodies/cerd/](http://www2.ohchr.org/english/bodies/cerd/)
6. Committee on Economic, Social and Cultural Rights (CESCR) – International Covenant on Economic, Social and Cultural Rights, [www2.ohchr.org/english/bodies/cescr/](http://www2.ohchr.org/english/bodies/cescr/)
7. Committee on the Protection of the Rights of All Migrant Workers and Members of Their Families – International Convention on the Protection of the Rights of All Migrant Workers and Members of Their Families, [www2.ohchr.org/english/bodies/cmw/](http://www2.ohchr.org/english/bodies/cmw/)

Ipas has compiled the specific text from these and other conventions relevant to maternal mortality, unwanted pregnancy and abortion into three documents:

- Maternal Mortality, Unwanted Pregnancy and Abortion as Addressed by International Human Rights Bodies: Part One, [www.ipas.org/~media/Files/Ipas%20Publications/IHRCOMPAE12.ashx](http://www.ipas.org/~media/Files/Ipas%20Publications/IHRCOMPAE12.ashx)
- Part Two, [www.ipas.org/~media/Files/Ipas%20Publications/IHRCOMPBE12.ashx](http://www.ipas.org/~media/Files/Ipas%20Publications/IHRCOMPBE12.ashx)
- Part Three, [www.ipas.org/~media/Files/Ipas%20Publications/IHRCOMPCE12.ashx](http://www.ipas.org/~media/Files/Ipas%20Publications/IHRCOMPCE12.ashx)

# Community Linkages

## Key topics in this module:

- Partnerships with the community
- Community assessments
- Community-based interventions

## 1.0 Introduction

As with other essential health services, it is the obligation of health systems to make postabortion care available in communities where women live and work. Communities can play a key role in reducing maternal mortality and morbidity by partnering with facilities that offer sexual and reproductive health services to ensure that women have the information, support and means to access the care they need. In turn, health-care workers can reach out to community members to establish such partnerships. By working closely with the communities they serve, service providers can better understand women's life circumstances, the barriers to care they may face, and what women consider high-quality care. Mutual trust can be built through close, meaningful interactions between community members and health-facility personnel, leading to better care for women, including young women.

### Community Advisory Committees

*A Community Advisory Committee is made up of leaders in community, and serves as a steering committee for the project or services. It usually includes 12-20 interested individuals from the community, including young people and influential members from different sectors. The purpose of the group is to tailor the services or a project to the needs of the community, to gain the support of the whole community, and to provide general guidance.*

*The Committee should understand the reproductive health issues affecting the community, and often have direct access to those who can most benefit from information about these health services. The Committee can broaden the impact of health promotion, improve health services and reinforce relationships between the health services and the community at large. All Committee members should be active, and their ideas and opinions should be valued. The responsibilities of advisory committee members typically include:*

- *Advocacy*
- *Information and outreach in the community*
- *Informed guidance of project or services*
- *Holding health authorities accountable for providing needed services and using government funds appropriately*

The term *community* is commonly used to designate people residing in a common geographic location, such as a village or town. However, many diverse communities exist that are based on specific, shared interests or among people with a common history, culture or shared social, political or economic interest.

Such definitions stress the similarities and shared interests of community members. In reality, however, differences of opinion and conflicts also exist. These differences can have a significant impact on the health and well-being of community members, especially women.

The issue of abortion, in particular, can be very sensitive and a source of conflict within a given community. Overt or even subtle harassment of health workers who provide abortion-related care by community members can have a negative impact on provision of or access to care.

Providers may want to identify allies who can help educate community members about unsafe abortion and the need for postabortion care and promote women's access to high-quality care.

Postabortion care providers and other facility staff need to take an active role in building partnerships with community members. To establish strong relationships with community members, health workers can:

- Provide high-quality, respectful care to all women who seek services and protect women's confidentiality;
- Inform and consult with community leaders and representatives of different segments of the community, such as different ethnicities and young women;
- Establish ongoing mechanisms for community involvement in assessments of service delivery, adverse events, recommendations for quality improvements and positive community-provider partnerships, such as community advisory committees (see box) that include diverse representatives. When adverse events occur, facilitate discussions to prevent misunderstandings and even potential threats to providers;
- Set up community-based health worker outreach programs to provide locally appropriate information, support and care to community members.

Community members can also be proactive in defining community perspectives and problems and proposing appropriate solutions. Together, providers and community members can improve the quality of care and women's access to services.

## **2.0 Community assessment**

Community residents have a vested interest in their own health, safety and well-being. Rather than making assumptions, it is very important to gather information directly from community members as well as representative leaders and really listen to what women, including young women, say about health-related concerns and resources. Health-care providers can begin to create links in the community by identifying and talking with representational leaders, such as:

- Local government officials
- Traditional leaders
- Health-committee members
- Leaders of women's, men's and youth groups
- Religious leaders
- Law-enforcement officials
- Traditional birth attendants/quacks, homeopaths and medicine/faith healers
- Community-based health workers
- Student leaders

A special effort should be made to include young women in conversations with the community. They, and other groups in the community, may be hesitant to speak openly about their concerns, so one-on-one or small conversations may be productive.

Health-facility personnel and/or members of the community can conduct a community or situational assessment in order to better understand community members' health-related perceptions, challenges and resources that might affect service delivery and access. Community assessment surveys can determine to which reproductive health services women have access, what women's prior experiences with the health system have been, what existing health structures and mechanisms are in place, what is important to women and their families, and what is relevant to their real-life circumstances. Community members, as well as health-facility personnel, may require some guidance on how to do an assessment. This is an opportunity to create those skills in the community, which may also be useful in improving other health services. These findings will be critical to building partnerships and delivering care that meets community members' needs.

General elements of a community assessment might include:

- Where and how people prefer to receive sexual and reproductive health-related information;
- What sexual and reproductive health resources are available and whether women know about them;



- Where women in the community might be accessing abortion outside of the formal health system— from chemical sellers, traditional birth attendants (TBAs) and lay health workers and healers;
- How community members define high-quality care and competent health-care providers;
- Public-health issues of greatest concern and other issues that impact health, such as poverty, high unemployment and substandard housing, clean water and sanitation;
- Community perspectives about abortion and postabortion care;
- The level of concern about maternal mortality and morbidity and whether unsafe abortion is understood to be a contributing factor;
- Women’s prior experiences with local health care facilities;
- What health services and community support mechanisms are in place to specifically address women’s needs;
- What is important to women and their families;
- What is important specifically to young women.

### **3.0 Community-based interventions**

Health-care providers can use information gathered in the community assessment to design interventions that link abortion-related services and community members. Providers should be open to implementing community-generated solutions to problems. Interventions are most effective when they are community driven and championed by local, recognized leaders who can provide credibility and sustainability.

Women, their husbands and families need information about:

- Pregnancy signs and symptoms;
- Pregnancy options;
- Availability of contraceptive services, including emergency contraception;
- Dangers of unsafe abortion;
- Legal indications for induced abortion where applicable (for example, to save the life of the woman);
- Where they can obtain induced abortion for legal indications, if any;
- Where they can obtain care for abortion-related complications;
- Importance of seeking abortion-related care only from trained and authorized providers.

Women need to be able to exercise their reproductive rights, and providers should do what they can to facilitate that. They can do so in the following ways:

- *Educate women and their husbands about human reproduction, contraception and pregnancy options.* For example, health-care personnel can organize community

meetings and conduct educational sessions or train community-based health workers to do so.

- *Educate community leaders about the need for comprehensive sexual and reproductive health education for all women including young women.* Ensure they understand that information does not lead to wayward behavior but rather leads to better decision-making, more protected sex and fewer unplanned pregnancies and unsafe abortions.
- *Create a partnership with women.* Use this partnership to define and design more accessible and appropriate postabortion care for *all* women, evaluate quality of services, and influence quality improvement efforts.
- *Train and equip community-health workers to provide contraceptive counseling and method provision and referrals so women can get their contraceptive needs met closer to home.* Health-facility staff can identify resources and develop a referral system to accommodate women who need specialized services.
- *Train community health workers or local volunteers to refer women in emergency situations.* Making referrals to healthcare services, following up with women after treatment and linking women to other needed services are important referrals that community health workers can make.
- *Work with the community to set up systems for identification of complications of an unsafe abortion, and emergency transportation to a facility for immediate care.* In addition, the community can help find other ways to mobilize resources to ensure timely care for abortion complications.
- *Alert the community to negative public-health trends.* For example, if many women are coming in to health facilities with complications from unsafe abortion, providers could meet with community leaders to encourage local education on safe services and assistance for women who need care. Providers must always take care to maintain women's confidentiality.
- *Increase awareness and support for postabortion care providers.* Providers can conduct values clarification workshops in the community to increase knowledge. This would also create support and reduce stigma for women who have abortions and providers who offer abortion-related care. Health managers can make announcements, postings and media messages to ensure that the public is aware of their facility's services and commitment to uphold their confidentiality policies. Public campaigns can encourage women to only seek abortion-related care from trained and authorized providers.
- *Educate pharmacists and other drug sellers and women about misoprostol for postpartum haemorrhage and postabortion care.* Providers can educate women, pharmacists and others who use or dispense medications about proper doses of misoprostol for postabortion care and prevention and treatment of postpartum haemorrhage.

- *Identify community, regional or national resources available to meet specific client needs and develop a referral system to accommodate women who need specialized services.*

(For more information, please see Appendix A: Potential Audiences and Topics for Information, Education and Communication on Postabortion Care.)

### 3.1 Ensure immediate treatment of complications

Rates of abortion-related morbidity and mortality can be reduced by providing three key services:

- Early counseling
- Referrals for treatment of complications
- Adequate follow-up care

#### **Key messages:**

- *Preventing unwanted pregnancy is crucial to reducing abortion*
- *Legal indications for abortion in the country or region*
- *Women must avoid untrained providers and unsafe conditions*
- *If a woman has any problems after having an abortion she should go to a health facility as soon as possible.*

Providers can work with community leaders to educate women about the signs and symptoms of miscarriage or abortion complications that require prompt medical attention. They should also ensure that the women know where emergency care is available. Communities can pool resources to set up an emergency transportation system to prevent delays in getting women prompt treatment help for obstetrical emergencies. Health-facility staff can train community health workers or local volunteers to refer women in emergency situations to health-care services, to follow up with women after treatment and to link women to contraceptive services.

### 3.2 Monitor service delivery

Health facilities can form community advisory or quality of-care committees to assist in assessing services, making recommendations for improvements, and participating in the implementation of recommendations as appropriate. Health facility managers and providers can also train community members to conduct client-satisfaction surveys within the clinic or in the community, taking into account the need for client privacy and confidentiality. An important aspect of working with communities is to work with people on how to understand and use the collected information. Please see the Monitoring to Improve Services module for more information.)

Health providers should also consider attending appropriate local meetings to share their monitoring results and steps taken to enhance services. These exchanges can be useful in motivating community members to provide input for service-delivery improvements.

### 3.3 Share information about preventing infection

People who live near health-care facilities may be concerned about infectious waste, including products of conception. Health managers should share the protocols for infectious-waste disposal with community leaders, and work with them to ensure that the public's

health is protected. Health-care workers can also educate women and community members about actions they can take to prevent infections.

Improper processing and disposal of medical instruments is a public-health risk, particularly in settings where there are untrained providers and unhygienic conditions.

The risk of infection can be reduced when:

- Used medical instruments and other medical waste are disposed of appropriately, not in open dumps or other places the public can access;
- Health-care workers follow proper instrument-processing techniques and do not carry pathogens from the facility into the community.

(Please see the Infection Prevention module for more information.)

### 3.4 Advocate for improved policies

Health-care workers and community members can organize grassroots campaigns that encourage local representatives to prioritize sexual and reproductive health and rights. They can advocate that local health-care facilities offer postabortion care services. They can also advocate that facilities provide safe postabortion/ abortion services to the fullest extent of the law, and for improved access to reproductive health care for young women.

If providers see that large numbers of women need specialized services—such as screening, counseling, support or treatment for Hepatitis B and C and HIV—they can work with community leaders to advocate that health systems fill those service gaps. Community agencies and individuals may be interested in initiating services, such as support groups or peer education, on a volunteer basis.

## 4.0 Summary

- Partnerships between health-facility staff and communities play a key role in reducing maternal mortality and morbidity.
- Providers should be aware of their role in the community as role models and leaders, while working in partnership with community members to advance women's health.
- Community Advisory Committees can be a good way to partner with the community to take action, make changes, or monitor success.
- Include all women including those from vulnerable populations in community partnerships.

### Ways to increase public awareness of postabortion care services

- *Consistently deliver respectful, high quality care*
- *Advertise services*
- *Post signs, mural or billboards on health facilities or in communities*
- *Develop and disseminate community-specific flyers and mass-media messages*
- *Attend community activities*
- *Facilitate community discussions*
- *Use local media outlets such as newspaper and radio*
- *Encourage satisfied clients to talk to others*

- Community assessments can inform providers and other stakeholders about general health conditions and about abortion-related issues.
- Providers and staff members at health facilities, in coordination with or through community leaders, can raise public awareness about reproductive rights and provide information on sexuality, reproductive health and abortion-related care.
- Early referral for abortion complications and follow-up care are critical steps in reducing maternal morbidity and mortality. Communities can take steps to help prevent delays in getting women with obstetrical emergencies to life-saving health services.
- Health facilities that involve the community in monitoring service delivery can better ensure that community needs are met and that woman-centered PAC is accessible.
- Communities surrounding health-care facilities may be at risk for exposure to infectious waste, and health managers have a responsibility to ensure that proper protocols for infection prevention are followed.
- Communities and health staff can work together to advocate that authorities prioritize sexual and reproductive health and rights, provide necessary services, and adopt policies that serve women's needs.

## References

- Corbett, M. R., & Turner, K. L. (2003). Essential elements of postabortion care: Origins, evolution and future directions. *International Family Planning Perspectives*, 29(3), 106-111. Ipas. (2013).
- Johnston, H. B., Ved, R., Lyall, N., & Agarwal, K. (2001). From community to action: Managing postabortion complications and their management: A community assessment conducted in rural Uttar Pradesh, India. *PRIME Technical Report*, 23.
- McInerney, T., Baird, T. L., Hyman, A. G., & Huber, A. B. (2001). *Guide to providing abortion care*. Chapel Hill, NC: Ipas.
- Pathfinder International. (2001). Tapping community opinion on postabortion care services. *Pathfinder Technical Guidance Series*, 2.
- Postabortion Care (PAC) Consortium. (2013). Postabortion Care (PAC) Consortium. From <http://www.pac-consortium.org/>
- Rogo, K. O., Bohmer, L., & Ombaka, C. (1999). Developing community-based strategies to decrease maternal morbidity and mortality due to unsafe abortion: pre-intervention report. *East African Medical Journal*, 76(11 Suppl), S1-71.
- Turner K.L. & A. Huber (Eds.). *Woman-centered, comprehensive abortion care: Reference manual*, (Second ed.). Chapel Hill, NC: Ipas.
- Turner, K. L., Borjesson, E., Huber, A., & Mulligan, C. (2011). *Abortion care for young women: A training toolkit*. Chapel Hill, NC: Ipas.
- Varkey, S. J., Fonn, S., & Ketlhapile, M. (2001). *Health workers for choice: Working to improve quality of abortion services*. Johannesburg, South Africa: Women's Health Project, University of Witwatersrand.

## Appendix A: Potential audiences and topics for information, education and communication on postabortion care

Audience	Content	Communication Venues and Media
<ul style="list-style-type: none"> <li>• Young and adult women, their husbands, family members or guardians, teachers, women’s groups, men’s groups, adolescent groups, student groups, community groups, unions and apprentice groups including clubs based on sports, social exchange, theater/arts, etc.</li> <li>• Taxi drivers, pharmacists, and other local informants such as traditional midwives or birth attendants</li> </ul>	<ul style="list-style-type: none"> <li>• <b>Unwanted pregnancy:</b> Signs and symptoms of pregnancy and where to go for assistance; importance of seeking care early; pregnancy complications and where to go for assistance, dangers of unsafe abortion</li> <li>• <b>Abortion:</b> Abortion laws and service policies; where, how to recognize abortion complications and where and when to seek help; quick return to fertility after abortion; community role in emergency care in recognition and transport</li> <li>• <b>Contraception:</b> Information about modern methods of contraception (including emergency contraception), including safety and effectiveness; where and how methods can be obtained</li> </ul>	<ul style="list-style-type: none"> <li>• <b>Venues:</b> Health service facilities, schools and universities, workplace, youth centers, women’s centers, group meetings, markets</li> <li>• <b>Media:</b> Newspapers, magazines, posters, flyers, radio, TV, talks, dramas</li> </ul>
<ul style="list-style-type: none"> <li>• Health system officials, legislators and other policymakers</li> <li>• Professional associations (medical, legal, etc.)</li> <li>• Members of media</li> <li>• Non-traditional leaders such as film and sports stars</li> </ul>	<ul style="list-style-type: none"> <li>• Prevalence, health and resource impact of unsafe abortion and unwanted pregnancies on women and families</li> <li>• Women’s rights regarding abortion and postabortion care</li> <li>• Relevant access issues and the impact on health and resources</li> <li>• Costs of providing emergency treatment for unsafe abortion</li> <li>• Need to legislate for funding of high-quality</li> <li>• RH health services for women</li> </ul>	<ul style="list-style-type: none"> <li>• <b>Venues:</b> Conferences, governmental hearings</li> <li>• <b>Media:</b> Conversation, research reports for meetings and legislative hearings, communications to the staff of these officials, workshops, letter-writing campaigns, all other print and electronic media</li> </ul>
<ul style="list-style-type: none"> <li>• Traditional and religious leaders</li> </ul>	<ul style="list-style-type: none"> <li>• Importance of educating constituents to prevent and seek help with unwanted pregnancies</li> <li>• Where and how contraception and other RH services can be obtained</li> <li>• Relative costs to families and the community of maternal morbidity and mortality due to unwanted pregnancy and unsafe abortion</li> <li>• Current abortion law and service policies</li> <li>• How to counsel about pregnancy care and availability of family planning</li> </ul>	<ul style="list-style-type: none"> <li>• <b>Venues:</b> Formal and informal community and religious meetings, workshops by health professionals</li> <li>• <b>Media:</b> Conversation, dramas, talks, print and electronic media</li> </ul>

*Adapted from McInerney et al, 2001s*

# Uterine Evacuation Methods

## Key topics in this module:

- Recommended methods for evacuating the uterus: misoprostol, vacuum aspiration and expectant management
- Possible risks and side effects, cost and benefits of these methods

## 1.0 Introduction

Uterine evacuation is the removal of the contents of the uterus.

There are three recommended methods for evacuating the uterus in cases of incomplete and missed abortion, with uterine size under 13 weeks (3 months):

- Misoprostol
- Vacuum aspiration (electric or manual)
- Expectant management

Uterine evacuation to remove retained pregnancy tissue is often a life-saving component of postabortion care, so health-care workers who will be treating women with abortion-related complications, as well as those who will be providing safe abortion services, should be clinically competent in performing or facilitating uterine evacuation.

### *Misoprostol*

The medication misoprostol can be taken to empty the uterus. This is sometimes referred to as misoprostol for postabortion care (MPAC). WHO states that “medical methods of



abortion have been proved to be safe and effective.” Misoprostol is on WHO’s Model List of Essential Medicines, as well as the Interagency List of Essential Medicines for Reproductive Health, compiled by several of the UN agencies and other international NGOs.

### *Vacuum Aspiration*

During vacuum aspiration, the contents of the uterus are evacuated through a plastic or metal cannula using suction provided by a handheld, portable aspirator (manual vacuum aspiration) or by an electric pump (electric vacuum aspiration). Vacuum aspiration is an important alternative to and occasional back-up for medical abortion.

### *Expectant management*

Expectant management is a closely monitored process that allows the woman’s body to expel the uterine contents without any procedure or uterotonic medications. It is only appropriate for women having an uncomplicated spontaneous abortion.

This module is focused on uterine evacuation in the first trimester.

Many different types of health-care professionals can safely perform or assist with uterine evacuation. Pre- or in-service training provides an opportunity for health-care workers to achieve clinical competence in this skill.

This module provides:

- A brief overview of recommended uterine-evacuation methods for uterine size under 13 weeks;
- Information on clinical safety and effectiveness, cost, acceptability to women;
- Specific risks and side effects associated with each method.

This information is also summarized in Appendix A: PAC treatment options.

Sharp curettage (dilatation and curettage/ D&C) is not recommended by WHO. A description of the technique is included because it is still used in many settings.

## **2.0 Misoprostol**

Misoprostol can be used to expel the contents of the uterus. It was developed for gastrointestinal indications but also has the effect of softening the cervix and stimulating uterine contractions. It is used for many obstetric and gynecologic indications including labor induction, medical abortion, treatment of incomplete abortion, prevention and treatment of postpartum hemorrhage and cervical preparation.



**Misoprostol tablets**

### *Clinical safety and effectiveness*

Misoprostol for incomplete abortion has average efficacy rates of 91-99 percent reported in the literature, depending on the regimen used and the study. Misoprostol has been used safely for incomplete abortion in many different

countries, and shows similar success to VA. It has not been associated with any long-term effects on women's health. Misoprostol is not advised in cases where delayed uterine evacuation could add significant risk to the woman. In such cases, vacuum aspiration is the preferred method of treatment.

For missed abortion, a single dose of misoprostol results in successful uterine evacuation in more than 80 percent of women. Some studies have used repeat doses of misoprostol 800mcg vaginally after 24 or 72 hours with a resulting increase in the complete abortion rates. However, it is unclear whether the increase in complete abortion is due to the additional prostaglandin dose or the increased time to evaluation. When women are managed expectantly after a single dose of misoprostol, their complete abortion rates increase over time. Misoprostol repeated every three hours for a maximum of two more doses achieves similar success rates.

#### **Possible complications**

*Complications of medical methods are rare. However, possible complications include:*

- *Incomplete evacuation*
- *Infection*
- *Hemorrhage*
- *Allergic reaction*
- *Failed abortion*

Most women undergoing uterine evacuation with medical methods experience some amount of abdominal cramping and bleeding. Other possible side effects, depending on dosage and route of administration, include vomiting, nausea, diarrhea, chills and fever.

#### *Cost*

The cost of a uterine evacuation depends on the clinical regimen, the technology, and the cost of providing backup in case reevacuation is needed. Uterine evacuation with misoprostol is considered a low-cost treatment.

Misoprostol is a simple medication that is easy to store (no refrigeration required and a long shelf life) and use in a range of settings, by a range of clinicians. Misoprostol can stand alone where aspiration services are not feasible, or complement vacuum aspiration where there are existing postabortion care (PAC) services. Data from several studies show that in many settings, reorganizing services by reclassifying PAC treatment as an outpatient care procedure substantially reduces the resources used for PAC, along with the cost and average length of women's stay in health facilities. Misoprostol can substantially reduce service costs, allowing women to seek treatment for incomplete abortion at the primary care level and thus reducing the caseload at tertiary care facilities.

#### *Acceptability to women*

In studies reviewing acceptability, more than 90 percent of women have reported being satisfied or very satisfied with misoprostol for their postabortion treatment. A feasibility study in Nigeria showed high acceptability to women among a largely Muslim population in the north. The same study showed that participating clinicians (including doctors, midwives and nurses) also reported a high degree of satisfaction.

Women should be given a choice of method whenever possible and be provided sufficient information to make an informed decision.

(Please see the Uterine Evacuation with Misoprostol module for more information.)

### 3.0 Vacuum aspiration

Vacuum aspiration is considered an essential service by many national and international authorities such as WHO and the International Federation of Gynecology and Obstetrics (FIGO).

#### *Description*

Vacuum aspiration is a method by which the contents of the uterus are evacuated through a plastic or metal cannula that is attached to a vacuum source.

- Manual vacuum aspiration (MVA) uses a hand-held, portable aspirator.
- Electric vacuum aspiration (EVA) employs an electric pump.

#### **Potential side effects of all uterine evacuation procedures**

- *Abdominal cramping*
- *Nausea*
- *Vomiting*
- *Pain*
- *Bleeding*

The level of vacuum provided by the MVA aspirator decreases as the cylinder fills with blood and tissue, but an electric pump provides a constant level of suction.

The procedure involves dilating the woman's cervix if necessary, inserting a cannula through the cervix into the uterine cavity, and attaching the cannula to the vacuum source. The uterine contents are then suctioned out. Depending on the uterine size and amount of tissue, the procedure takes from 3 to 10 minutes to complete.

#### *Clinical safety and effectiveness*

Vacuum aspiration is extremely effective and safe, and is successful in 98 to 100 percent of cases for treatment of incomplete abortion. The method results in few complications, especially when performed up to 13 weeks uterine size. Safety and programmatic benefits of vacuum aspiration, compared to sharp curettage, include:

- Reduced blood loss
- Reduced procedure time
- Reduced risk of major and minor complications
- Reduced pain
- Reduced cost

Because many providers do sharp curettage in an operating theater with heavy sedation or general anesthesia, anesthetic risks are decreased with vacuum aspiration.

### Cost

Vacuum aspiration can be much less costly when performed on an outpatient basis. Vacuum aspiration can result in savings to the facility that can then be passed on to the woman.

### Acceptability to women

Vacuum aspiration is well-accepted by women, including young women. Because vacuum aspiration is less painful than sharp curettage, in most cases vacuum aspiration requires lower levels of pain management. Typically a combination of local anesthesia (paracervical block), oral analgesics and verbal reassurance allows women to be awake and aware of what is happening during the procedure but still have adequate pain control. Light sedation may also be added if it is available and desired by the woman. With lower levels of pain medication, postabortion care can be provided in an outpatient setting, which is generally more acceptable to women than a hospital stay.

### Possible Complications

When vacuum aspiration is performed by well-trained providers, complications are rare. However, possible complications include:

- *Incomplete evacuation*
- *Cervical or uterine injury, such as perforation or tearing*
- *Anesthesia complications*
- *Infection*
- *Hemorrhage*
- *Hematometra*
- *Failed abortion*

*In rare cases, these conditions can result in secondary infertility, other serious injury or death. WHO, in conjunction with the United Nations Population Fund (UNFPA), the United Nations Children's Fund (UNICEF), and the World Bank and with endorsement by FIGO and the International Confederation of Midwives (ICM), endorses MVA as an essential technology for uterine evacuation.*

## 3.1 Manual vacuum aspiration (MVA)

In an MVA procedure, a hand-held plastic 60cc aspirator providing a vacuum source is attached to a cannula and hand-activated to suction out the uterine contents. To perform the MVA procedure, a cannula of the appropriate size is inserted through the dilated cervix into the uterus. The cannula is attached to a vacuum charged aspirator, and the vacuum is released by depressing the buttons on the aspirator. The cannula is gently and slowly rotated while it is moved back and forth within the uterus. The aspirator serves as the source of vacuum to pull the products of conception through the cannula into the cylinder.

MVA is safe and effective:

- It can be performed by trained midlevel providers with no difference in complications rates compared to doctors.
- It does not require electricity and can be used in decentralized, rural settings with intermittent electrical supply.
- It can be provided in a clinic setting on an outpatient basis, requiring fewer facility resources and reducing cost of care.

- Where instruments can be reused, the cost per procedure can be relatively low.
- Reduced waiting times and increased local availability of care make this an acceptable method for many women, including young women.
- MVA creates little noise during the procedure, which some women find preferable.

(Please see the Uterine Evacuation Procedure with Ipas MVA Plus module for more detailed information on MVA.)

### 3.2 Electric vacuum aspiration

EVA uses an electric pump or suction machine attached to a cannula to evacuate the uterine contents. The cannula is inserted into the uterus and then attached to the suction-machine tubing. The thumb valve on the hose is then opened and the machine turned on. The cannula is rotated gently back and forth until the pregnancy is evacuated through the hose and into a glass container at the end of the hose.

- Because the initial cost of an EVA machine is high, it is typically used in centralized settings with high caseloads.
- EVA is less appropriate for settings with intermittent electrical supply.
- EVA has been found acceptable to women, including young women.

## 4.0 Expectant management

Many women who present with a spontaneous abortion can be successfully managed without any intervention. Allowing this process to follow a natural course, while closely monitoring to ensure that all uterine contents are fully expelled, is known as expectant management. Before offering expectant management ensure that the woman is properly counseled.

### *Clinical safety and effectiveness*

Success rates for expectant management differ based on the type of abortion and the length of follow-up. Women who present with bleeding and an incomplete abortion have faster resolution and higher success than women with a missed abortion. (Please see Appendix A: PAC treatment options.) In addition, the longer a woman waits for follow-up, the higher likelihood she has of success. If a woman waits for 7 to 14 days, approximately 75 to 85 percent of women with an incomplete abortion and 30 to 60 percent of women with a missed abortion will successfully pass their pregnancy. Over one quarter of women who choose expectant management for miscarriage management will need a procedure to complete the uterine evacuation.

### **Importance of counseling for expectant management**

*It is important to inform women about how long it might take to achieve complete abortion so they know what to expect. Expectant management can be continued as long as the woman is willing and provided there are no signs of infection. For some women, the duration can be as long as 6-8 weeks.*

*Access to emergency care is important in case any products of conception are retained and cause complications (i.e. infection or heavy bleeding). Effectiveness varies and vacuum aspiration may still be necessary.*

### Cost

There is no cost to women unless they return to the facility in need of a procedure for uterine evacuation or if they experience complications.

### Acceptability to women

Satisfaction data have been reported in only a minority of trials and differences appear to be small with the various methods. Women who are managed according to their choice are generally satisfied with their method and express a preference for the same method for future treatment.

Factors that may make expectant management more acceptable to women include the fact that they can use the method at home, that it is private, and that it is a natural process.

## 5.0 Other methods: Sharp curettage

### Description

Sharp curettage, also known as dilatation and curettage (D&C), involves dilating the cervix and using a sharp metal curette to scrape the uterine walls. During the procedure, the woman usually receives general anesthesia or heavy to light sedation.

According to the WHO, "Dilatation and curettage (D&C) is an obsolete method of surgical abortion and should be replaced by vacuum aspiration and/or medical methods.

"A statement by the International Federation of Gynecology and Obstetrics (FIGO) supports the use of vacuum aspiration or medications over sharp curettage for uterine evacuation. Sharp curettage is still common in many countries; therefore health system officials and administrators should make all possible efforts and be supported to replace sharp curettage with vacuum aspiration or misoprostol.

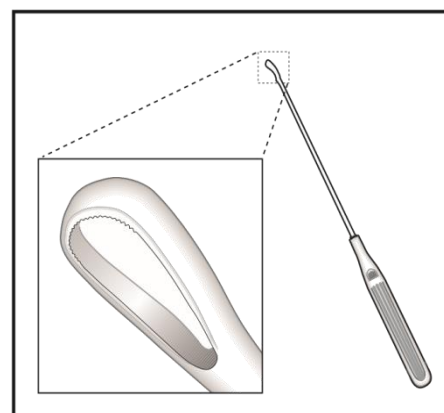

Figure 1 Metal curette

### Clinical safety and effectiveness

Sharp curettage is associated with increased blood loss, pain and procedure time when compared to vacuum aspiration for uterine evacuation.

### Cost

Sharp curettage is typically performed in an operating theater, under general anesthesia, and involves a hospital stay. All these factors increase the cost of care.

*Acceptability to women*

The higher doses of pain medication typically used with sharp curettage, including general anesthesia, often necessitate longer and costlier hospital or clinic stays that may be less acceptable to women. The higher risks associated with this method also make it less preferable.

**Treatment of second-trimester abortion complications**

*For PAC treatment in a woman with a uterus over 13 weeks size, products of conception (POC) may be already partially expelled or still in the uterus. Options for treatment include uterine evacuation with medications or MVA with or without use of specialized forceps.*

*Uterine evacuation with medications:*

- *Misoprostol in a dose of at least 200mcg vaginally, sublingually or buccally may be given every six hours until expulsion. Pretreatment with mifepristone may reduce induction to abortion interval.*
- *Pain management needs are generally higher than with first trimester PAC.*
- *Typically, this process is performed while the woman remains in a health care facility by providers who have been trained in these methods.*

*MVA with or without use of specialized forceps:*

- *The size and type of incomplete abortion determines if an MVA alone can completely empty the uterus or the use of specialized forceps are needed as well which requires a provider who has been trained in this technique (dilation and evacuation).*
- *Greater dilation is needed compared to procedures performed at earlier stages of pregnancy. Cervical dilation may already be present but if not, cervical preparation can be achieved using mechanical dilators, medications such as misoprostol, or a combination of both.*
- *Utilization of larger cannulas (10, 12 or, when available, 14) can also aid in complete evacuation.*
- *Pain management needs are generally higher than with first trimester PAC. Pharmacological pain management, such as light sedation, and occasionally general anesthesia may be needed.*

**6.0 Summary**

- Three recommended methods of first-trimester uterine evacuation are misoprostol, vacuum aspiration and expectant management.
- Misoprostol for incomplete abortion is safe and acceptable, including for young women, and is successful in 91-99 percent of cases.
- Vacuum aspiration for first-trimester uterine evacuation is safe and acceptable, including for young women, and is successful in 98 to 100 percent of cases.

- Providers need to take the following factors into consideration when determining which uterine evacuation method to use: the woman's personal preferences, clinical condition; uterine size, availability of equipment, supplies and skilled staff; and currently available scientific and medical evidence.
- Sharp curettage is not recommended because it is less safe than other methods. If uterine evacuation is not currently being provided, vacuum aspiration and medical methods should be introduced first.



## References

- Balogh, S. A. (1983). Vacuum aspiration with the IPAS Modified Gynecologic Syringe. *Contraception*, 27(1), 63-68.
- Billings, D. L., & Benson, J. (2005). Postabortion care in Latin America: policy and service recommendations from a decade of operations research. *Health Policy and Planning*, 20(3), 158-166.
- Bique, C., Usta, M., Debora, B., Chong, E., Westheimer, E., & Winikoff, B. (2007). Comparison of misoprostol and manual vacuum aspiration for the treatment of incomplete abortion. *International Journal of Gynecology and Obstetrics*, 98(3), 222-226.
- Blumenthal, P. D., & Remsburg, R. E. (1994). A time and cost analysis of the management of incomplete abortion with manual vacuum aspiration. *International Journal of Gynecology and Obstetrics*, 45(3), 261-267.
- Caceres, G. H., Riaño Gamboa, G., Hernández, M. A., & López Escobar, G. (1981). Hospital management of incomplete abortion: Comparative study of dilation and curettage versus vacuum aspiration. Bogota, Columbia: Corporacion Centro Regional de Poblacion.
- Chen, B. A., & Creinin, M. D. (2007). Contemporary management of early pregnancy failure. *Clinical Obstetrics and Gynecology*, 50(1), 67-88.
- Clark, S., Blum, J., Blanchard, K., Galvão, L., Fletcher, H., & Winikoff, B. (2002). Misoprostol use in obstetrics and gynecology in Brazil, Jamaica, and the United States. *International Journal of Gynecology and Obstetrics*, 76(1), 65-74.
- Dalton, V. K., & Castleman, L. (2002). Manual vacuum aspiration for treatment of early pregnancy loss. *Postgraduate Obstetrics and Gynecology*, 22(19), 1-6.
- Dalton, V. K., Harris, L., Weisman, C. S., Guire, K., Castleman, L., & Lebovic, D. (2006). Patient preferences, satisfaction, and resource use in office evacuation of early pregnancy failure. *Obstetrics and Gynecology*, 108(1), 103-110.
- Dao, B., Blum, J., Thieba, B., Raghavan, S., Ouedraogo, M., Lankoande, J., & Winikoff, B. (2007). Is misoprostol a safe, effective and acceptable alternative to manual vacuum aspiration for postabortion care? Results from a randomised trial in Burkina Faso, West Africa. *BJOG: An International Journal of Obstetrics and Gynaecology*, 114(11), 1368-1375.
- Demetroulis, C., Saridogan, E., Kunde, D., & Naftalin, A. A. (2001). A prospective randomized control trial comparing medical and surgical treatment for early pregnancy failure. *Human Reproduction*, 16(2), 365-369.
- Diop, A., Raghavan, S., Rakotovo, J. P., Comendant, R., Blumenthal, P.D., & Winikoff, B. (2009). Two routes of administration for misoprostol in the treatment of incomplete abortion: a randomized clinical trial. *Contraception*, 79(6), 456-462.
- El Kabarity, H., S Abo Louz, A El Etribi, M Yehya and A Ellian. (1985). Suction abortion versus traditional evacuation in the management of incomplete inevitable abortions. Unpublished paper presented at the International College of Surgeons, Fifth African Federation, Cairo.
- Federacion Latino Americana de Sociedades de Obstetricia y Ginecologia. (2007). *Uso de misoprostol en obstetricia y ginecologia, segunda edicion*. A. Faúndes (Ed.)
- Ferris, L. E., McMain-Klein, M., Colodny, N., Fellows, G. F., & Lamont, J. (1996). Factors associated with immediate abortion complications. *Canadian Medical Association Journal*, 154(11), 1677-1685.
- Forna, F., & Gülmezoglu, A. M. (2001). Surgical procedures to evacuate incomplete abortion. *Cochrane Database SystRev* (1), CD001993.
- Gabbe, S. G. (2002). *Obstetrics: Normal and problem pregnancies (Fourth ed.)*. New York: Churchill Livingstone.
- Gabbe, S. G., Niebyl, J. R., Simpson, J. L., & Annas, G. J. (1996). *Obstetrics: Normal and problem pregnancies (Third ed.)*. New York: Churchill Livingstone.

- Geyman, J. P., Oliver, L. M., & Sullivan, S. D. (1999). Expectant, medical, or surgical treatment of spontaneous abortion in first trimester of pregnancy? A pooled quantitative literature evaluation. *Journal of the American Board of Family Practice*, 12(1), 55-64.
- Gilles, J. M., Creinin, M. D., Barnhart, K., Westhoff, C., Frederick, M.M., & Zhang, J. (2004). A randomized trial of saline solution-moistened misoprostol versus dry misoprostol for first-trimester pregnancy failure. *American Journal Of Obstetrics and Gynecology*, 190(2), 389-394.
- Goldberg, A. B., Carusi, D., & Westhoff, C. (2009). Pregnancy Loss. In M. Paul (Ed.), *Management of Unintended and Abnormal Pregnancy*. Oxford, England: Wiley-Blackwell.
- Goldberg, A. B., Greenberg, M. B., & Darney, P. D. (2001). Misoprostol and pregnancy. *New England Journal of Medicine*, 344(1), 38-47.
- Graziosi, G. C., Mol, B. W., Ankum, W. M., & Bruinse, H. W. (2004). Management of early pregnancy loss. *International Journal Of Gynaecology And Obstetrics*, 86(3), 337-346.
- Greenslade, F., Leonard, A. H., Benson, J., Winkler, J., & Henderson, V. (1993). *Manual vacuum aspiration: A summary of clinical & programmatic experience worldwide*. Carrboro, NC: Ipas.
- Gynuity Health Projects. (2009). *Misoprostol for treatment of incomplete abortion: An introductory guidebook*. New York, NY: Gynuity Health Projects.
- Hu, D., Grossman, D., Levin, C., Blanchard, K., Adanu, R., & Goldie, S. J. (2010). Cost-effectiveness analysis of unsafe abortion and alternative first-trimester pregnancy termination strategies in Nigeria and Ghana. *African Journal of Reproductive Health*, 14(2), 85-103.
- International Federation of Gynecology and Obstetrics. (2011). *Consensus statement on uterine evacuation* (pp. 2). London, UK: International Federation of Gynecology and Obstetrics.
- Ipas. (2003). *Factsheets on using the pharmaceutical agents mifepristone and misoprostol for abortion care and other pregnancy-related services*. Chapel Hill, NC: Ipas.
- Ipas Nigeria, & Society of Gynaecology and Obstetrics of Nigeria (SOGON). (2010). *Notes from the field: Resource needs and considerations for the introduction of misoprostol into existing PAC services. Results of a study conducted by the Society of Gynaecology and Obstetrics of Nigeria and Ipas* (pp. 1-2). Abuja, Nigeria: Ipas Nigeria.
- Ipas Nigeria, & Society of Gynaecology and Obstetrics of Nigeria (SOGON). (2011). *Offering misoprostol as an alternative to manual vacuum aspiration for treatment of incomplete abortion in Nigeria: Lessons from a multi-site introduction*. Abuja, Nigeria: Ipas.
- Johnson, B. R., Benson, J., Bradley, J., & Ordonez, A. R. (1993). Costs and resource utilization for the treatment of incomplete abortion in Kenya and Mexico. *Social Science & Medicine*, 36(11), 1443-1453.
- Jowett, M. (2000). Safe Motherhood interventions in low-income countries: An economic justification and evidence of cost effectiveness. *Health Policy*, 53(3), 201-228.
- Kittiwatanakul, W., & Weerakiet, S. (2012). Comparison of efficacy of modified electric vacuum aspiration with sharp curettage for the treatment of incomplete abortion: randomized controlled trial. *Journal of Obstetrics and Gynaecology Research*, 38(4), 681-685.
- Koontz, S. L., Molina de Perez, O., Leon, K., & Foster-Rosales, A. (2003). Treating incomplete abortion in El Salvador: cost savings with manual vacuum aspiration. *Contraception*, 68(5), 345-351.
- Lukman, H. Y., & Pogharian, D. (1996). Management of incomplete abortion with manual vacuum aspiration in comparison to sharp metallic curette in an Ethiopian setting. *East African Medical Journal*, 73(9), 598-603.
- Magotti, R. F., Munjinja, P. G., Lema, R. S., & Ngwalle, E. K. (1995). Cost-effectiveness of managing abortions: manual vacuum aspiration (MVA) compared to evacuation by curettage in Tanzania. *East African Medical Journal*, 72(4), 248-251.
- Mahomed, K., Healy, J., & Tandon, S. (1994). A comparison of manual vacuum aspiration (MVA) and sharp curettage in the management of incomplete abortion. *International Journal of Gynecology & Obstetrics*, 46(1), 27-32.

- Marshall, B. R. (1971). Emergency room vacuum curettage for incomplete abortion. *Journal of Reproductive Medicine*, 6(4), 177-178.
- Muffley, P. E., Stitely, M. L., & Gherman, R. B. (2002). Early intrauterine pregnancy failure: a randomized trial of medical versus surgical treatment. *American Journal Of Obstetrics And Gynecology*, 187(2), 321325; discussion 325-326.
- Nanda, K., Lopez, L. M., Grimes, D. A., Peggia, A., & Nanda, G. (2012). Expectant care versus surgical treatment for miscarriage. *Cochrane Database of Systematic Reviews*, 3, CD003518.
- Neilson, J. P., Gyte, G. M., Hickey, M., Vazquez, J. C., & Dou, L. (2010). Medical treatments for incomplete miscarriage (less than 24 weeks). *Cochrane Database of Systematic Reviews*, 20(1), CD007223.
- Ngoc, N. T., Blum, J., Westheimer, E., Quan, T. T., & Winikoff, B. (2004). Medical treatment of missed abortion using misoprostol. *International Journal of Gynaecology And Obstetrics*, 87(2), 138-142.
- Pauleta, J. R., Clode, N., & Graça, L. M. (2009). Expectant management of incomplete abortion in the first trimester. *International Journal of Gynecology and Obstetrics*, 106(1), 35-38.
- Peretz, A., Grunstein, S., Brandes, J. M., & Paldi, E. (1967). Evacuation of the gravid uterus by negative pressure (suction evacuation). *American Journal of Obstetrics & Gynecology*, 98(1), 18-22.
- Schüler, L., Pastuszak, A., Sanseverino, T. V., Orioli, I. M., Brunoni, D., Ashton-Prolla, P., Koren, G. (1999). Pregnancy outcome after exposure to misoprostol in Brazil: A prospective, controlled study. *Reproductive Technology*, 13(2), 147-151.
- Shwekerela, B., Kalumuna, R., Kipingili, R., Mashaka, N., Westheimer, E., Clark, W., & Winikoff, B. (2007). Misoprostol for treatment of incomplete abortion at the regional hospital level: Results from Tanzania. *BJOG*, 114(11), 1363-1367.
- Sotiriadis, A., Makrydimas, G., Papatheodorou, S., & Ioannidis, J. P. (2005). Expectant, medical, or surgical management of first-trimester miscarriage: A meta-analysis. *Obstetrics and Gynecology*, 105(5 Pt 1), 1104-1113.
- Tang, O. S., & Ho, P. C. (2006). The use of misoprostol for early pregnancy failure. *Current Opinion in Obstetrics and Gynecology*, 18(6), 581-586.
- Tang, O. S., Lau, W. N., Ng, E. H., Lee, S. W., & Ho, P. C. (2003). A prospective randomized study to compare the use of repeated doses of vaginal with sublingual misoprostol in the management of first trimester silent miscarriages. *Human Reproduction*, 18(1), 176-181.
- Tang, O. S., Ong, C. Y., Tse, K. Y., Ng, E. H., Lee, S. W., & Ho, P. C. (2006). A randomized trial to compare the use of sublingual misoprostol with or without an additional 1-week course for the management of first trimester silent miscarriage. *Human Reproduction*, 21(1), 189-192.
- Tasnim, N., Mahmud, G., Fatima, S., & Sultana, M. (2011). Manual vacuum aspiration: A safe and cost-effective substitute of electric vacuum aspiration for the surgical management of early pregnancy loss. *Journal of the Pakistan Medical Association*, 61(2), 149-153.
- Trinder, J., Brocklehurst, P., Porter, R., Read, M., Vyas, S., & Smith, L. (2006). Management of miscarriage: expectant, medical, or surgical? Results of randomised controlled trial (miscarriage treatment (MIST) trial). *BMJ*, 332(7552), 1235-1240.
- Tunçalp, O., Gülmezoglu, A. M., & Souza, J. P. (2010). Surgical procedures for evacuating incomplete miscarriage. *Cochrane Database Systemic Review* (9), CD001993.
- Vazquez, J. C., Hickey, M., & Neilson, J. P. (2001). Medical management for miscarriage (Cochrane Review). *The Cochrane Library*, Issue 2.
- Velázquez, J. F., Wrooman, E., Cuevas, R. P., Flores, B. O., & Pérez, A. C. (2001). Evaluación de la introducción de aspiración manual endouterina en hospitales del IMSS. *Revista Médica del IMSS*, 39(5), 393-401.
- Weeks, A., Alia, G., Blum, J., Ekwaru, P., Durocher, J., & Winikoff, B. (2005). A randomized trial of misoprostol compared with manual vacuum aspiration for incomplete abortion. *Obstetrics and Gynecology*, 106(3), 540-547.

Wieringa-de Waard, M., Bindels, P. J. E., Vos, J., Bonsel, G. J., Stalmeier, P. F. M., & Ankum, W. M. (2004). Patient preferences for expectant management vs. surgical evacuation in first-trimester uncomplicated miscarriage. *Journal of Clinical Epidemiology*, 57(2), 167-173.

World Health Organization. (1994). *Clinical management of abortion complications: A practical guide*. Geneva: World Health Organization.

World Health Organization. (2007). *Managing complications in pregnancy and childbirth: A guide for midwives and doctors integrated management of pregnancy and childbirth (IMPAC), second edition*. Geneva: World Health Organization.

World Health Organization. (2012). *Safe abortion: Technical and policy guidance for health systems, (second ed.)*. Geneva: World Health Organization.

Zhang, J., Gilles, J. M., Barnhart, K., Creinin, M. D., Westhoff, C., & Frederick, M. M. (2005). A comparison of medical management with misoprostol and surgical management for early pregnancy failure. *New England Journal of Medicine*, 353(8), 761-769.

**Appendix A: PAC Treatment Options**

	<b>Expectant Management</b>	<b>Electric Vacuum Aspiration</b>	<b>Manual Vacuum Aspiration</b>	<b>Misoprostol</b>
<b>How it works</b>	Allows the uterus to evacuate the products of conception by spontaneous uterine contractions over time without provider intervention  Natural process  Throughout the first trimester	A procedure that uses electric suction instruments inserted into the uterus to remove the products of conception  Uterine size less than or up to 13 weeks from LMP	A procedure that uses manual suction instruments inserted into the uterus to remove the products of conception  Uterine size less than or up to 13 weeks from LMP	Causes contractions that expel remaining products of conception  Uterine size less than or up to 13 weeks from LMP
<b>Safety</b>	Emergency access to emergency care is important in case any products of conception are retained and cause complications (i.e. infection)	Low risk of infection or injury  Little or no cervical dilation  Low blood loss  Short outpatient stay	Low risk of infection or injury  Little or no cervical dilation  Low blood loss  Short outpatient stay	Referral relationship to a facility with vacuum aspiration must be established
<b>Effectiveness</b>	Effectiveness varies and vacuum aspiration may still be necessary  Up to 84%	98-100%	98-100%	91-99% *Average is 95%
<b>Cost considerations</b>	No cost	Cost effective if done on an outpatient basis under local anesthesia  EVA machine is expensive – requires constant supply of electricity	Cost effective if done on an outpatient basis under local anesthesia  MVA instrument is inexpensive	Inexpensive

**Appendix A: PAC Treatment Options (continued)**

	<b>Expectant Management</b>	<b>Electric Vacuum Aspiration</b>	<b>Manual Vacuum Aspiration</b>	<b>Misoprostol</b>
<b>Accessibility</b>	<p>Women can use this method at home</p> <p>Needs to happen under the supervision of a trained provider (including mid-level)</p>	<p>Can be used in mid-level as well as high level health facilities in clean conditions with proper provider training</p>	<p>Can be used in low-level health care facility, in clean conditions with proper provider training</p> <p>Readily available in most settings</p>	<p>Can be provided in any health facility or family planning clinic</p> <p>Women can use this method at home</p>
<b>Acceptability to women</b>	<p>Women can remain awake</p> <p>Private</p> <p>More natural/like miscarriage</p> <p>Need time and patience</p>	<p>Women can remain awake</p>	<p>Women can remain awake</p>	<p>Women can remain awake</p> <p>Private</p> <p>More natural/like miscarriage</p>
<b>Expected effects</b>	<p>Bleeding and cramping</p>	<p>Bleeding and cramping</p>	<p>Bleeding and cramping</p>	<p>Bleeding and cramping</p>
<b>Side effects</b>	<p>None</p>	<p>None</p>	<p>None</p>	<p>Nausea, vomiting, fever and chills</p>

# Monitoring to Improve Services

## Key topics in this module:

- Definition of monitoring
- Key steps of monitoring
- What to monitor

## 1.0 Introduction

Every health service can benefit from routine monitoring. Monitoring helps ensure that postabortion care (PAC) services achieve and maintain a level of quality that is satisfactory to both clients and providers. This module includes the:

- Key characteristics of effective monitoring systems;
- Steps involved in monitoring;
- Aspects of postabortion care service delivery that should be routinely assessed;
- Importance of adverse event monitoring and reporting.

## 2.0 What is monitoring and why is it important?

*Monitoring* is a way of using information to identify strengths and weaknesses, provide feedback, and make adjustments to improve PAC quality of care. Monitoring examines all aspects of care, including client satisfaction that may not be addressed through other means. Regular monitoring and adjustment help ensure that clients receive high-quality PAC services and that health-care workers have the resources and support they need for

service delivery. Monitoring is an ongoing process that should be continued whenever and wherever PAC services are provided.

Monitoring can range from inexpensive and simple to more complete, formalized approaches. A simple approach may be to only monitor a few indicators, whereas more formalized approaches usually encourage assessment and monitoring across a wide range of service delivery components.

**Table 5-1: Examples of facility-level monitoring**

<b>Objective</b>	<b>Current Monitoring Data</b>	<b>Previously Collected Data</b>	<b>Improvement Plan</b>
All PAC patients treated within two hours of arriving at facility.	Patient waiting time for treatment is three hours on average.	Compared with data one year prior, patient waiting time has increased by 30 minutes.	Admission procedures will be streamlined to reduce patient waiting time.
100% of PAC clients receive individualized counseling with a counselor.	65% of PAC clients receive individualized counseling with a counselor.	Compared with data one year prior, individualized counseling has increased 40%.	Private counseling spaces will be expanded and additional counselors trained to increase individualized counseling.
Essential supplies to high-level disinfect MVA instruments available 100% of the time.	Instrument-processing chemicals are available 70% of the time. Deliveries of these chemicals are often one to three weeks late.	Compared with data 6 months prior, availability of instrument-processing chemicals increased 10%.	While an increase in availability is positive, the goal is 100% availability.  An administrative change will be made to order instrument-processing chemicals well in advance to ensure adequate supplies despite late deliveries.

Information for monitoring can be gathered using existing or slightly modified routine information-collection systems, such as service delivery logbooks, service statistics and client records. Monitoring tools measure the same services at several points over time. The resulting “time series” information provides a long-range overview of how services change over time. Monitoring information enables providers and managers to recognize trends and



identify problem areas, make necessary adjustments to services and check that these adjustments have had the desired effect.

Monitoring should be conducted at both public-sector and private-sector health facilities. The number and complexity of activities will vary according to the availability of staff and resources. In larger health facilities, administrators and managers usually conduct monitoring activities. In smaller facilities, providers may need to do the monitoring themselves.

The following table provides brief examples of facility-level monitoring that can be accomplished without complex information-gathering or analysis tools. These examples illustrate that monitoring works best when it is carried out over a period of time, with ongoing evaluations and updated improvement plans. Note that actual improvement plans would be more specific, including details on when, where, how and by whom the recommended steps would be carried out.

### 3.0 Keys to effective monitoring systems

Monitoring is most effective when it:

*...is integrated into routine work*

When monitoring adds too many extra steps, the process becomes time-consuming and burdensome for health-care workers. Information gathered for monitoring purposes can be gathered from existing sources such as logbooks and service statistics.

*...uses simple indicators*

A small number of simple, thoughtfully chosen indicators can provide invaluable information about service provision.

*...is participatory and open*

When the monitoring process is genuinely inclusive of all health-care staff members, they are more likely to feel a sense of ownership of the results. Staff should be trained to use monitoring tools so they can incorporate monitoring into their responsibilities.

*...is conducted in an ethical manner*

#### Using indicators

*Indicators are measurements that help quantify activities and results. It is important to pick indicators that are actually under staff control, otherwise the process can be very demotivating. The sample indicators below can help describe the overall quality of postabortion care:*

- *Number and type of procedures performed, by age of the client;*
- *Number and type of complications;*
- *Number and percentage of women desiring contraception who receive a contraceptive method, by age;*
- *Number of referrals made;*
- *Number and percentage of women screened for sexually transmitted infections, including HIV;*
- *Number and percentage of women screened for exposure to violence;*
- *Number and percentage of women satisfied with services, by age.*

*Monitoring the proportion of services for women with obstetric complications that are abortion-related helps to assess the demand placed upon health care systems by abortion complications. It also may be useful to collect information on the method of unsafe abortion women present with (for example, if they seem to have already taken misoprostol as compared to having had an unsafe surgical procedure), and use this information to focus community education activities.*

Women’s privacy and confidentiality must be respected at all times. Informed consent must be obtained before women are interviewed or any provider-client interactions are observed. (Please see Appendix A: Written Consent Form – Interview and Appendix B: Written Consent Form – Observation for examples.)

*...is not punitive*

Monitoring is most effective when staff monitor themselves and the information gathered is used as a basis for reward and recognition.

*...includes recipients of the services, including young women* in the design and implementation of the monitoring process.

Conducting exit interviews, focus groups, or client satisfaction checklists is a good way to get information directly from the users of services to make improvements in quality of care.

#### **4.0 Adverse event monitoring**

Adverse events are complications that a woman suffers during care that are not a result of a disease. Although adverse events are rare in routine postabortion care, it is important to monitor for adverse events because each event offers the opportunity to learn about how to provide better, safer care for women. A distinction should be made in the logbook between any complications the woman may present with and complications arising from postabortion care services.

(Please see the Complications module for further information about the steps in adverse events monitoring and reporting.)

#### **5.0 Four steps of effective monitoring**

Monitoring involves four basic steps:

##### *Step 1: Planning*

Develop a monitoring plan that specifies how information will be collected, shared and analyzed. Involve a range of stakeholders in the planning process.

The plan should include:

- Members of the monitoring team, comprising a range of staff and recipients of services, including young women, and how team members will be trained;
- Aspects of services to be monitored;
- Quality standards and indicators to measure them;
- Sources of information, such as logbooks with service statistics and client records;
- Methods for gathering information, such as interviews, focus groups, observation and records review;
- Checklists and other tools to guide observations, interviews and records review. Checklists should include the essential features of delivery of high-quality care, such

as the availability of supplies, use of preferred medical techniques and quality of counseling (please see Appendix C: Client record-review checklist);

- A plan for sharing results with staff and the community, and improving services, if needed;
- A timeline for the monitoring process, with information about activities and persons responsible for their completion.

The following table illustrates aspects of postabortion care that could be monitored and provides some sample questions.

*Step 2: Information gathering*

Once the monitoring team has developed checklists and other tools, they can begin collecting information. There are several ways to gather data:

- Use information that is routinely collected by the health facility in logbooks, clinical records and supply ledgers: Local analysis of these data also prevents redundant monitoring and promotes collaboration between the administration and providers.
- To measure a change in a specific area of service delivery, use the same indicator over time.
- Conduct periodic observation and client interviews to examine aspects of service delivery such as quality of client-provider interaction and client satisfaction. Staff should make sure to seek young women’s perspectives.

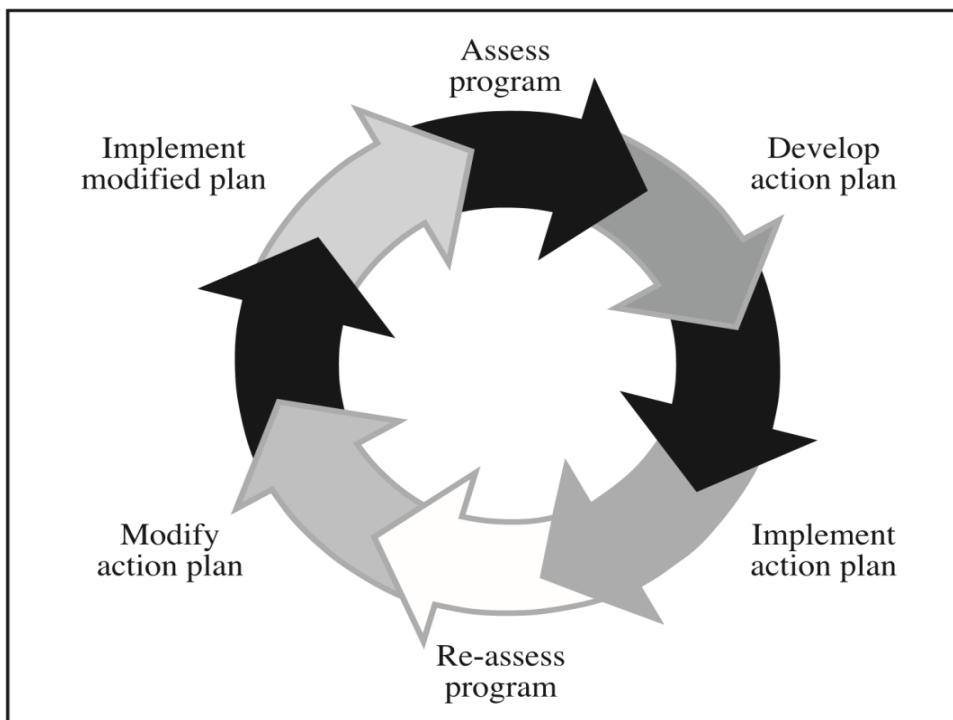

Monitoring is a continuous process

Table 5-2: Examples of postabortion care monitoring

<b>Types of Services</b>  What services should be monitored?	<b>Indicators</b>  What will we use to measure our activities?	<b>Information Sources</b>  Where can we get this information?	<b>Checklists, Questionnaires and Exit Interviews</b>  What type of questions should we ask?
Assessment and treatment plan	Percentage of PAC cases in which patients were assessed immediately for shock	Observe PAC services using performance checklists	Were PAC patients assessed for shock upon arrival?
Management and organization of services	Average amount of time patients receiving postabortion care spend in the facility  Average amount of time from arrival to PAC procedure  Hours during which PAC services are available	Observe and evaluate clinic flow  Review patient records and conduct interviews with staff	During which times of the day does patient waiting time increase?
Counseling	Number and percentage of patients receiving PAC counseling	Observe counseling services using checklists  Review recent PAC cases in logbooks  Use “mystery patient” questionnaire forms	Were patients with special needs given appropriate referrals when necessary?
Contraceptive counseling and services	Number and types of contraceptives dispensed on site  Number and percentage of patients who received contraceptive counseling  Number and percentage of patients desiring contraception who received a method	Observe counseling services using performance checklists  Conduct exit interviews with patients  Review recent PAC cases in logbooks	How well was the patient counseled about which contraceptive methods are available?  Did the patient leave with the desired method or information?  Did the patient have to go to another facility to receive a contraceptive method?
Patient satisfaction	Percentage of patients who agree that clinic costs are reasonable  Percentage of patients who are satisfied with PAC services	Conduct exit interviews with patients	Do you think the amount you had to pay for services was reasonable?

Please see Appendix A: Written consent form – interview and Appendix B: Written consent form – observation for examples.

The monitoring team should identify themselves, explain to the woman why she is being observed or interviewed and ask her permission to continue. The interview or observation must not proceed if the woman does not give her consent. Monitors must also ensure that privacy and confidentiality is respected. Clients’ names and unique identifying information should not be included on data forms.

The data that were collected during the information-gathering process should be compiled for review by the monitoring team. The review of monitored data presents an opportunity for health-care staff to openly discuss the facility’s strengths and weaknesses. Compile the findings, and review the data to:

- Reveal problem areas
- Develop improvement plans
- Assess progress in improving care

*Quantitative data* reveals numbers and straightforward facts. For example, clinic visits have dramatically decreased in the past two months.

*Qualitative data*, such as interviews, can be used to complement quantitative information. For example, exit interviews revealed that women were dissatisfied with the quality of counseling.

### Step 3. Analysis

Once the staff has a better understanding of the issues, they can look deeper into the underlying causes of the identified problems. Health-care staff must ask, “What factors contributed to these problems?” In the example above, poor-quality counseling services might stem from inadequate training of newly hired staff and a client-intake process that leaves insufficient time for counseling. The staff review may also identify causes that are more pervasive—for instance, an underlying belief that counseling is not an important part of services. Staff should also seek input from clients and community members to determine the root cause of a problem or issue.

#### **Low-literacy client satisfaction assessment**

*One low-literacy approach to assess client satisfaction is for staff to give each client a small bean which they place in a box upon exiting the facility. The bean indicates how they feel about their care that day. The box is divided into 3 sections and each has a face on it expressing feelings - a happy face, a blank or flat expression face, and a sad face. The staff use this as a qualitative sample of what clients think about services as part of their performance quality monitoring.*

### Step 4: Action planning

The team should first assess which problems can be addressed with relative ease, given the available resources. They can then formulate a plan of action. Include young people from the community in discussing how to address problems in services for young people. A range of approaches to each problem should be discussed before making a decision on the best possible solution.

Alternate solutions should be listed as potential future options in case the initial solution does not meet expectations.

To create an action plan:

- Draft a written plan that includes a timeline for implementation and assessment;
- Specify who will be responsible for implementing each step of the proposed solution;
- Discuss the plan with staff members who may help implement the steps;
- Present the findings and proposed solutions to the entire staff. This is an opportunity to obtain valuable staff feedback.

**Solutions to problems in postabortion care might include:**

- *Providing on-the-job training;*
- *Reorganizing clinic services;*
- *Changing clinic hours of operation;*
- *Revising systems for procuring and storing supplies;*
- *Strengthening referral systems.*

Share positive findings with staff and community members, when appropriate, including areas of strength and competency and any improvements that have been made. Staff contributions that have led to improved services should be recognized so that staff members can celebrate their successes.

## 6.0 Summary

- Monitoring is essential to ensuring that women receive high-quality postabortion care and that health-care workers have the resources they need to provide high-quality care.
- Monitoring is an ongoing process that works best when it is consistent and continuous and when the same tools are used to periodically measure results.
- Monitoring should fit into the routine work of the facility, use simple indicators, be open and participatory, and be performed ethically.
- When possible, monitoring should include input and participation of community members or clients who have received services.
- Monitoring should not be an overly complex or punitive process.
- Adverse event monitoring and reporting are key components of quality services.
- The four stages of monitoring are planning, information gathering, analysis and action planning.

## References

- Adamchak, S., Bond, K., MacLaren, L., Magnani, R., Nelson, K., & Seltzer, J. (2000). *A guide to monitoring and evaluating adolescent reproductive health programs*. Washington, DC: Focus on Young Adults.
- Bruce, J. (1990). Fundamental elements of the quality of care: a simple framework. *Studies in Family Planning*, 21(2), 61-91.
- EngenderHealth. (2003). *COPE® Handbook: A process for improving quality in health services*, revised edition. New York, NY: EngenderHealth.
- EngenderHealth, Ipas, & Reducing Maternal Mortality and Morbidity Project Ghana. (2009). *COPE for comprehensive abortion care services: A toolbook to accompany the COPE® Handbook*. New York, NY: EngenderHealth.
- Garcia-Nunez, J. (1992). *Improving family planning evaluation: A step-by-step guide for managers and evaluators*. West Hartford, CT: Kumarian Press.
- Huezo, C., & Diaz, S. (1993). Quality of care in family planning: Clients' rights and providers' needs. *Advances in Contraception*, 9(2), 129-139.
- King, T. D. N., Abernathy, M., & Hord, C. (1998a). A guide to assessing resource use in the provision of postabortion care: DataPAC Module 3 *DataPAC Core Questionnaire Series*. Carrboro, NC: Ipas.
- King, T. D. N., Abernathy, M., & Hord, C. (1998b). A guide to using the general information questionnaire for postabortion care patients: DataPAC Module 1. *DataPAC Core Questionnaire Series*. Carrboro, NC: Ipas.
- Leonard, A., & Winkler, J. (1991). A quality of care framework for abortion care. *Advances in Abortion Care*, 1(1).
- Management Sciences for Health (MSH). (1997). Using evaluation as a management tool. *The Family Planning Manager*, 6(1).
- McInerney, T., Baird, T. L., Hyman, A. G., & Huber, A. B. (2001). *Guide to Providing Abortion Care*. Chapel Hill, NC: Ipas.
- Otsea, K., Benson, J., Measham, D., Thorley, M., & Lidh, R. (1999). Monitoring postabortion care. *Technical resources for postabortion care* (Vol. 3). Carrboro, NC: Ipas.
- United Nations Children's Fund. (1997). *Guidelines for monitoring the availability and use of obstetric services*. New York, NY: United Nations Children's Fund (UNICEF).

## Monitoring Appendix A: Written consent form – interview

*Statement requesting to interview woman after receipt of postabortion care:*

**Interviewer:**

*Hello, my name is \_\_\_\_\_, and I am working with a team that is monitoring service quality. We would like to help improve the services provided by this facility and would like to find out your views about the services you received.*

*I would like to ask you a few questions about the discussions you had with the staff and the procedure you have just undergone. I will not write your name on the data-collection form. Everything you tell me will be kept strictly confidential and will be shared only with other team members. No one will be able to identify you from the information we collect. Your participation is voluntary, and you do not have to answer questions you do not want to answer.*

*Do I have your permission to continue?*

**Client:**

*Yes, you have my permission.*

Signature \_\_\_\_\_ Date \_\_\_\_\_

Witness \_\_\_\_\_ Date \_\_\_\_\_

Name of Facility

\_\_\_\_\_



## Monitoring Appendix B: Written consent form – observation

*Statement requesting to observe woman during her uterine evacuation:*

**Interviewer:**

*Hello, my name is \_\_\_\_\_, and I am working with a team that is monitoring service quality. We would like to help improve the services provided by this facility by observing the care you will receive.*

*I will not write your name on the data-collection form. Everything I observe will be kept strictly confidential and will be shared only with other team members. No one will be able to identify you from the information we collect. Your participation is voluntary, and you do not have to allow me to observe if you do not want to. If you do not wish to participate, this will not affect the care or services you receive today.*

*Do I have your permission to continue?*

**Client:**

*Yes, you have my permission.*

Signature \_\_\_\_\_ Date \_\_\_\_\_

Witness \_\_\_\_\_ Date \_\_\_\_\_

Name of Facility

\_\_\_\_\_

## Appendix C: Client record-review checklist

Site:	Reviewer:										Date:		
(Select 10 records at random and place a check mark if each of the items in the checklist was recorded on the corresponding client record.)													
Checklist Item	1	2	3	4	5	6	7	8	9	10	Total	Remarks	
1. Client registration no. and/or identification information													
2. Date of visit													
3. Woman's age or year of birth													
4. Woman's parity													
5. Health history													
6. Physical Exam													
7. Vital signs (temp, pulse, blood pressure)													
8. Uterine size (in weeks) and position													
9. Any presenting complications													
10. Diagnosis													
11. Medications and dosages used for pain management													
12. Signed informed consent form													
13. Uterine evacuation techniques													
14. Provision of comprehensive counseling													

Checklist Item	1	2	3	4	5	6	7	8	9	10	Total	Remarks
15. Contraceptive method selected and received prior to discharge (if desired)												
16. Other sexual and reproductive health services provided on-site (if needed)												
17. Referrals to other sexual and reproductive health services (if needed)												
18. Follow-up plans												
19. Provider's name and signature												
20. Detailed description of complication												
21. Detailed description of complication management												
22. Medications and dosages given												
23. Discharge status												
24. Informed consent form signed and included in record-pressure												

*Adapted from EngenderHealth, Ipas, Reducing Maternal Mortality and Morbidity Project Ghana, 2009.*

# Informed Consent, Information and Counseling

## Key topics in this module:

- Procedure options and informed consent
- Definition of woman-centered counseling
- Privacy and confidentiality
- Providers' values and empathy
- Special considerations

## 1.0 Introduction

A woman's experience during postabortion care (PAC) is both physical and emotional. Health-care providers should be prepared to offer effective and compassionate interaction, communication, emotional support and, if desired, counseling that focuses on the woman's needs. Each woman has unique circumstances surrounding her need for postabortion care, and she may be experiencing a range of emotions. The woman and provider may also have different values, social circumstances, cultures and speak different languages, which can create barriers to understanding. It is the provider's responsibility to recognize and positively address these barriers to be able to reach empathy and understanding.

*In cases of shock or other life-threatening conditions, a complete clinical assessment and voluntary, informed consent may be deferred until after the woman is stabilized. If a woman is in extreme pain or emotional distress, counseling should be offered when she is stable and able to comprehend and communicate.*

This module covers essential information about voluntary informed consent and counseling in a postabortion care setting and how providers can interact and communicate with clients in a respectful, effective manner. It also includes instructions on making appropriate referrals and information on counseling women with special considerations.

Effective PAC counseling occurs before, during and after the woman receives medical treatment. Whenever possible, counseling

should begin before treatment, as long as the woman's health is not placed at risk by the delay and she is able to understand information and make decisions. It is important that providers offer each woman who presents for postabortion care a formal counseling session with a trained provider at some point during her visit.

## 2.0 Voluntary informed consent

Informed consent is a process in which a woman gathers the information she needs to make a voluntary choice to undergo a uterine evacuation. To ensure that women are giving informed consent for the uterine evacuation, providers should discuss and confirm that women have understood:

- The benefits and risks of different methods of uterine evacuation;
- Consequences of not receiving postabortion care;
- Details of the planned procedure, once the method has been determined;
- Contraceptive choices and their effectiveness.

The benefits, risks and other information on recommended uterine evacuation methods can be found in the Uterine Evacuation Methods module, the Uterine Evacuation Procedure with Ipas MVA Plus® module, and the Uterine Evacuation with Misoprostol module. It may also be helpful to have the Appendix A: PAC Treatment Options of the Uterine Evacuation Methods module to show and discuss with women.

Providers need to explain this information in simple language and ensure that women have understood it. Privacy and confidentiality are critical to the informed consent process. Providers should remain mindful of any circumstances that may limit a woman's ability to make autonomous decisions, such as:

- Pain, blood loss, or other medical issues;
- Pressure from her husband or family members to select a particular method;
- Difficulty communicating due to language barriers, or because she is hard of hearing or deaf;
- Cognitive disability or mental illness;
- Mental immaturity;

- A traumatic event (such as violence or an unsafe abortion).

Young women are capable of making the decision to seek postabortion care. Because they are often not given adequate information or are specifically targeted with misinformation about sexuality, pregnancy and abortion, they may need more information to aid their decision-making and informed consent process. Young women have varying levels of maturity that do not always correspond with chronological age. Providers should listen to and talk with young women to gauge the degree of support they require. With correct information and support, young people are capable and have the right to make health-care decisions and provide informed consent for themselves.

### 3.0 Procedure options

Once a woman has made a decision to receive PAC treatment, the provider will discuss the uterine evacuation procedure options that are available in that facility and appropriate for that woman's clinical condition. The provider should explain the differences between all available methods and help the woman explore which option is best for her. They should discuss the possible benefits, risks and what to expect with each procedure. As long as the different methods are clinically appropriate, providers should refrain from inserting their own method preferences into the discussion and support a woman's decision. After all of the woman's questions about procedure options are answered and she has made her decision about which procedure to have, providers will obtain her consent for the procedure.

Once the woman makes a firm, voluntary decision about her method of treatment, the provider should establish the length of pregnancy and:

- Ensure visual and auditory privacy by asking the woman in private if she wishes to include a support person. *Only* invite that person to counseling if she desires their presence;
- Determine if the woman is capable of listening to and understanding the information;
- Assure the woman that any medical or personal information discussed during counseling is confidential, and make sure that information is not released without the woman's voluntary authorization;
- Affirm the positive step the woman has taken by seeking care;
- In clear, non-technical language, explain her medical eligibility for uterine evacuation methods and the pain medications available;
- Describe the nature and extent of any fetal anomalies or other medical indications;
- Obtain the woman's permission to treat her in the event of a complication or emergency;
- Encourage her questions and ensure that she understands the information provided; if she does not, explain it again in a simpler, more understandable way.

Providers should ask the woman—or her representative if she is unable to comprehend medical explanations—to give consent for care. Providers should confirm consent before beginning the uterine evacuation.

Once the woman has chosen, the provider should provide the following information:

- What will be done before during and after the procedure;
- What she is likely to experience—for example, cramps or pain;
- How long the procedure will take;
- Which pain management options she can choose;
- What side effects, risks and complications are associated with the method;
- What kind of aftercare and follow-up is needed.

*Providers should make sure the woman knows that she could ovulate almost immediately after uterine evacuation, which could quickly lead to another pregnancy if she resumes sexual intercourse without using a modern contraceptive method. If a woman desires contraception to prevent future pregnancy, the provider can ensure that she receives or is referred for appropriate contraceptive services during her visit. Most facilities can at the very least ensure that women receive an interim contraceptive method and a referral for a long-term contraceptive method before leaving the facility. (Please see the Contraceptive Services module for more information.)*

(Please see Appendix A: PAC Treatment Options in the Uterine Evacuation Methods Module, for a comparison of expectant management, VA and misoprostol for uterine size up to 13 weeks.)

#### 4.0 Counseling in the postabortion setting

Counseling is a structured interaction in which a person voluntarily receives emotional support and guidance from a trained person in an environment that is conducive to openly sharing thoughts, feelings and perceptions. Counseling offers an excellent opportunity for providers to determine and address each woman’s unique physical and emotional needs.

Effective counseling, characterized by a respectful, empathetic exchange between women and health-care workers, can help the woman make pregnancy and abortion-related decisions, feel affirmed in her decision and prepare for the abortion process. Effective counseling may improve women’s postabortion experience and outcomes and make them more inclined to trust health-care workers and seek appropriate medical care in the future. Although elements of effective counseling should be present throughout the visit, providers should offer women a formal counseling session if she desires it.

Woman-centered counseling is structured completely around each woman’s needs and concerns. There is not a pre-determined script or list of items to be covered and checked off. The provider considers each woman’s emotional and physical state, medical condition, cultural and religious background, ability to understand medical terms and general level of understanding. A provider can determine a woman’s most pressing concerns by asking open-ended questions about what she needs and how she can help and using the woman’s responses as the starting point for counseling.

Because many facilities do not have full-time counseling positions, existing staff members can be trained to provide basic abortion counseling. In cases where clinicians also function as providers, they must remain mindful that client-provider dynamics may differ from client-clinician relations. Whether or not they have formal counseling responsibilities, clinicians should possess counseling knowledge, an affirming, nonjudgmental attitude and caring and supportive behaviors. Providers should consider that this may have been a wanted pregnancy.

An effective postabortion care provider will:

- Solicit and affirm the woman's feelings;
- Elicit circumstances surrounding the pregnancy that have implications for her clinical care and referrals to other services she might need;
- Help the woman clarify her thoughts and decisions about her pregnancy, choices and her future sexual and reproductive health;
- Allow the woman to explore her feelings about abortion;
- Ensure that the woman receives appropriate answers to her questions and concerns, in language that she understands;
- Provide referrals to additional services if necessary;
- Help the woman determine who she might go to for social support, if she wants that. (See Appendix A for a list of organizations providing support to women in Pakistan.)

A postabortion care provider should NOT:

- Provide information that is not relevant to the woman's particular situation;
- Tell the woman what they think is best;
- Try to influence attitudes, beliefs and behaviors by persuading or threatening.

Please refer to the Uterine Evacuation with Misoprostol module for more information on counseling specific to medical methods. Please refer to Appendix B: Special Considerations for more information on counseling younger clients.

## **5.0 Privacy and confidentiality**

Women have the right to privacy and confidentiality when receiving postabortion care. In an environment where abortion laws are strict, women who have self-induced or obtained an abortion illegally may be scared that information will be reported to the police or other authorities. Providers should inform the woman that medical and personal information will not be given to others without her voluntary approval, except when it is legally required.

Ideally, all PAC-related counseling should take place in a setting where no one else can see or overhear and in which, communication between the woman and the provider is not shared with other clients, visitors, or staff members not involved in her direct care. Another individual - for example, a husband or family member - may ask to be included in the



counseling session. It is crucial for the provider to first meet with the woman alone and, at that time, ask her permission to invite anyone else to join the counseling session. By asking for her permission privately, she is less likely to feel pressured to include others in the counseling session.

In a counseling setting, informed decision making refers to the process by which a woman makes decisions of her own free will after she understands complete and accurate information. The provider should inform the woman that any medical or personal information discussed during counseling is confidential, and then ensure that this information is not released without the woman's voluntary authorization. Offering the woman respectful, confidential counseling in a private setting will contribute to her sense of dignity and the overall quality of her care.

## **6.0 Values and empathy**

Providers should extend compassion and respect to every woman, regardless of her circumstances. Providers should examine their attitudes and assess their potential biases against women who, for example:

- Do not want to be pregnant but do not use contraception;
- Undergo multiple abortions;
- Present later in pregnancy;
- Have multiple children or no children;
- Carry pregnancies to term even though the pregnancies were not intended or desired;
- Terminate a pregnancy due to fetal malformation;
- Have multiple sexual partners;
- Have been sexually assaulted;
- Are unmarried;
- Are of a certain race, ethnicity, social class, religion, age, sexual or gender orientation, health or STI status, or political affiliation;
- Have become pregnant while living with HIV;
- Have little or no formal education;
- Are sexually active at a young age.

Health-care providers' attitudes and beliefs affect their interactions and counseling with women and carry considerable influence. Providers may unconsciously hold beliefs about a woman's right to determine what happens in her body, and these may be linked to beliefs about gender, age, sexuality and other factors.

A woman-centered approach to care means that providers should:

- Identify their personal beliefs and values about abortion-related care and other factors such as gender, age and sexuality;

- Separate their beliefs and values from those of their clients and focus on their client's needs;
- Show respect to all women, regardless of their age, marital status, sexual and reproductive behaviors and decisions;
- Treat women with empathy—understanding their feelings and perspectives and communicating this understanding.

Values clarification can help providers identify their beliefs and values, explore the consequences of their actions, learn how to separate their values from those of their clients and offer care in a way that shows respect for a woman's rights and decisions. Clinic managers and clinical mentors can help establish and maintain an environment of sensitivity and respect for women's needs through a variety of methods, including values clarification and other training, clinical coaching, supportive supervision, feedback from coworkers, anonymous evaluations and client surveys.

## 7.0 Effective communication

Providers should strive to create a safe environment in which women can explore and validate their feelings. Effective providers remain open and nonjudgmental even when their personal beliefs differ from those of their clients. Providers should practice empathy, the ability to understand another person's feelings and point of view and to communicate this understanding. Providers should never insist that a woman talk or reveal information that she is not comfortable sharing. Counseling always involves two-way communication between the health-care provider and the woman. Each person spends time talking, listening, and asking and answering questions.

Providers who practice effective communication:

- Stay attentive and focused on the woman and her needs;
- Use nonverbal cues to convey interest in and concern for the woman, and observe her nonverbal cues;
- Ask open-ended questions and use encouraging words to help the woman talk openly;
- Let her talk before providing more information;
- Follow up with appropriate questions and feedback;
- Use words and language that are easily understandable, including for young women;
- Are warm and without bias, anger or judgment, including body language.

Providers who **do not** practice effective communication:

- Make judgments about a woman's behaviors;
- Make assumptions about the woman and her needs, or focus on their own priorities;
- Indicate a lack of interest through nonverbal cues and do not pay attention to the woman's nonverbal cues;

- Ask only closed-ended questions;
- Do not listen carefully, or show distraction;
- Interrupt or speak over the woman;
- Use medical terms or language that is difficult for women to understand;
- Do not check to make sure that the woman has understood their questions;
- Allow interruptions such as telephone calls or people coming into the counseling space;
- Feel they know what is best for the woman, better than the woman herself.

### 7.1 Active listening

*Active listening* involves more than just hearing. A provider who is practicing active listening uses multiple senses to gather relevant information, convey understanding and encourage the woman to talk about her feelings and circumstances. Some elements of active listening are:

- Showing attentiveness by interjecting phrases such as “I see” or “I understand”;
- Making encouraging sounds, facial expressions and gestures.

Providers should resist the temptation to offer statements that seem reassuring but make women feel unsupported or offer false reassurance. For example, saying “don’t worry,” or “everything will be fine” can make her feel that her concerns have been dismissed.

### 7.2 Open-ended questions and reflecting feelings

Open-ended questions cannot be answered with just “yes” or “no.” They begin with “how,” “what,” “when” and “tell me about.” Questions that require more complete answers elicit more information and require full engagement in the conversation.

- Avoid asking open-ended questions that begin with “why” as this may be perceived as judgmental. Instead, providers should ask open questions without judgment or assumptions. For example, “How are you feeling now that the uterine evacuation is complete?”
- Follow up the woman’s response with a statement that reflects understanding of her feelings and concerns.
- If the provider is unsure whether she has understood correctly, she can add a question at the end of the statement, such as, “Is that correct?” This gives the woman the opportunity to confirm or correct the provider’s understanding.

### 7.3 Nonverbal communication

By paying attention to nonverbal cues, a provider can more fully understand a woman’s feelings. Providers should remain observant about differences between a client’s verbal and nonverbal cues. For example, if a woman says she feels fine but has a sad facial expression, the provider may ask: “You say you feel fine, but you look sad—can you tell me more about that?”

A provider can use nonverbal communication to show concern for a woman by:

- Facing her or sitting beside her and removing any physical barriers between them such as a desk or counter;
- Leaning slightly forward and making appropriate eye contact for the context;
- Nodding and using a reassuring tone of voice;
- Avoid turning and looking away, repeatedly looking at a watch or clock or using a harsh tone of voice.
- Providers should remember that nonverbal cues vary from culture to culture, as well as according to age and gender within a given culture.

## 8.0 Referrals

If a provider is unable to adequately address the woman's needs, it is best to refer her to other appropriate individuals or services. To facilitate this process:

- Identify typical concerns clients have and create and maintain a list of local, current resources. Providers should be able to respond to questions about safe, legal abortion and where women can access such services, if available.
- Referrals should include accurate, easy-to-follow written or pictorial information. Ask each woman if it is safe for her to receive written referral information. For some women, it may be dangerous to receive information about abortion that may be found by someone else.
- Recommend services and facilities that are accessible to the woman, both geographically and financially, and assure her that she can return to this facility if she has trouble accessing the referred resource or it does not meet her needs.
- Ensure the referral site serves young women and that young women feel comfortable there before they are referred.
- Track referrals in the logbook where providers can write client's names, the service to which she was referred and details about follow-up care.

## 9.0 Closing a counseling session

When closing a counseling session, the provider should:

- Provide a short summary of the key concepts discussed.
- Ask the woman if she has any additional questions.
- Ensure that the woman understands any verbal instructions or suggestions.
- Provide the woman written or pictorial instructions or referrals, if appropriate.
- Explain what to expect during the remainder of the clinic visit.

## 10.0 Special considerations

Some clients may have special needs that they are not comfortable mentioning to a provider. Therefore, it is important that providers ask questions to elicit information about

each woman's situation and decision. Providers who are uncomfortable working with certain client populations may be able to obtain additional training to attain greater competency.

Alternately, providers can refer women to other providers or agencies who are skilled in providing high-quality services that meet special needs, such as:

- Women with multiple abortions
- Women who have experienced violence
- Women living with hepatitis B and C, and HIV
- Young women
- Commercial sex workers
- Women with cognitive and developmental disabilities and mental illness
- Refugees and displaced persons
- Women who have experienced female genital mutilation
- Women with advanced gestational age

(Please see Appendix B: Special Considerations for more information on this issue.)

## **11.0 Summary**

- In cases of shock or other life-threatening conditions, a complete clinical assessment and voluntary, informed consent may be deferred until after the woman is stabilized. If a woman is in extreme pain or emotional distress, counseling should be offered when she is stable and able to comprehend and communicate.
- To give voluntary informed consent, women must know all their options and their benefits and risks. They must also be able to choose without pressure or coercion.
- Young women are capable of making the decision to seek postabortion care, and may need more information to aid their decision-making and informed consent process.
- Health-care providers should explain the differences between all available uterine evacuation methods and help the woman explore which option is best for her.
- Health-care providers should be prepared to offer compassionate support and, if desired, counseling that focuses on the woman's needs.
- Woman-centered counseling is structured completely around each woman's needs and concerns, such as those of young women and other special considerations.
- Counseling should be conducted in an area where no one else can see or overhear.
- Information shared by the woman is confidential and should not be released without her voluntary authorization.

- Clients respond best to providers who provide nonjudgmental support, convey empathy and create a safe environment in which the woman is comfortable exploring her feelings.
- Woman-centered counseling includes such techniques as active listening, open-ended questioning, reflecting feelings and attention to nonverbal communication.
- Providers should examine their personal beliefs, values and potential biases so that they do not affect counseling.
- Referral protocols and resource lists that provide simple, accurate, up-to-date information are essential components of an effective referral service.
- Counseling should conclude with summarizing key concepts discussed, what to expect, and ensuring that the woman understood what was discussed and her needs were addressed.

## References

- American College of Obstetricians and Gynecologists. (2008). *Female genital cutting: Clinical management of circumcised women, second edition*. Washington, DC: American College of Obstetricians and Gynecologists (ACOG).
- Baker, A., & Beresford, T. (2009). Informed consent, patient education, and counseling. In M. Paul, E. S. Lichtenberg, L. Borgatta, D. A. Grimes & P. G. Stubblefield (Eds.), *A clinician's guide to medical and surgical abortion*. New York, NY: Churchill Livingstone.
- Cameron, S. T., & Glasier, A. (2012). Identifying women in need of further discussion about the decision to have an abortion and eventual outcome. *Contraception*, 88(1):128-32.
- Caralis, P. V., & Musialowski, R. (1997). Women's experiences with domestic violence and their attitudes and expectations regarding medical care of abuse victims. *South African Medical Journal*, 90(11), 1075-1080.
- Cook, R., & Dickens, B. (2000). Recognizing adolescents' 'evolving capacities' to exercise choice in reproductive healthcare. *International Journal of Gynecology & Obstetrics*, 70:13-21.
- Corbett, M. R., & Turner, K. L. (2003). Essential elements of postabortion care: Origins, evolution and future directions. *International Family Planning Perspectives*, 29(3), 106-111.
- De Bruyn, M. (2003). *Violence, pregnancy and abortion: Issues of women's rights and public health*, second edition. Chapel Hill, NC: Ipas.
- EngenderHealth. (1999). *Counseling the postabortion patient: Training for service providers*. New York, NY: EngenderHealth.
- Family Health International. (2003). *Reproductive health of young adults: Contraception, pregnancy and sexually transmitted diseases*. Research Triangle Park, NC: Family Health International.
- Gardner, R., & Blackburn, R. (1997). People who move: new reproductive health focus. *Population Reports, Series J* (45), 1-27.
- Hall, J. A., Roter, D. L., & Katz, N. R. (1988). Meta-analysis of correlates of provider behavior in medical encounters. *Medical Care*, 26(7), 657-675.
- Johns Hopkins School of Public Health. (1999). Pullout guide: What health care providers can do about domestic violence. *Population Reports, Series L* (11).
- Lansdown, G., & UNICEF. Innocenti Research Centre. (2005). *The evolving capacities of the child*. Florence, Italy: Save the Children: UNICEF.
- McIntyre, J. (1999). *HIV in pregnancy: A review*. Geneva, Switzerland: UNAIDS
- Postabortion Care (PAC) Consortium Youth-friendly Working Group. (2006). *Technical guidance on youth-friendly PAC*. Retrieved from <http://www.pac-consortium.org/attachments/article/19/YFPAC%20Tech%20Guidance.pdf>
- PRIME. (1997). *Reproductive health training for primary providers: A sourcebook for curriculum development*. Chapel Hill, NC: INTRAH.
- Turner, K. L., Borjesson, E., Huber, A., & Mulligan, C. (2011). *Abortion care for young women: A training toolkit*. Chapel Hill, NC: Ipas.
- Turner, K. L., & Page, K. C. (2008). *Abortion attitude transformation: A values clarification toolkit for global audiences*. Chapel Hill, NC: Ipas.
- United Nations (UN). (2009). *General Comment No.12: The right of the child be heard (CRC/C/GC/12)*. New York: United Nations (UN).
- United Nations (UN). (2003). *General Comment No.4: Adolescent health and development in the context of the Convention of the Rights of the Child (U.N. doc CRC/GC/2003/4)*. New York: United Nations (UN).
- United Nations Children's Fund.(2000). Domestic violence against women and girls. *Innocenti Digest*, 6.

United Nations High Commissioner for Refugees.(1995). *Sexual violence against refugees*. Geneva, Switzerland: United Nations High Commissioner for Refugees.

Winkler, J., & Gringle, R. E. (1999).*Postabortion family planning: A two-day training curriculum guide for improving counseling and services*. Chapel Hill, NC: Ipas.

World Health Organization (WHO). (1997). *Post-abortion family planning: A practical guide for programme managers*. Geneva: World Health Organization (WHO).

World Health Organization (2012). *Safe abortion: Technical and policy guidance for health systems*. Geneva: World Health Organization (WHO).

World Health Organization (WHO). (2013). Mother-to-child transmission of HIV. Retrieved from <http://www.who.int/hiv/topics/mtct/en/>

World Health Organization (WHO), & UNAIDS. (2007). *Guidance on provider-initiated HIV testing and counseling in health facilities* Retrieved from <http://www.who.int/hiv/pub/vct/pitc/en/index.html>



## Appendix A: Organizations Providing Social Support to Women in Pakistan

CITY	NAME OF AGENCIES	PHONE NUMBER	WEBSITE
All over Pakistan	Edhi Center	115	www.edhi.org
	Human Rights Commission of Pakistan	042 – 35838341 042 - 35864994	www.hrcp-web.org
Karachi	Ansar Burney Welfare Trust	021 - 32623382 021 - 32623383	www.ansarburney.org
	Citizen Police Liaison Committee (CPLC)	021 – 35682222 021 – 35683333	www.cplc.org.pk
	Lawyers for Human Rights & Legal Aid (LHRLA)	111 – 911 – 922 021 – 35674031	www.lhrla.com.pk
	Pakistan Women Lawyers Association	021 – 35673286	
	Panah	021 – 36360025 021 – 36360028	www.panahshelter.org
Karachi & Lahore	War Against Rape (WAR)	021 – 35373008	www.waragainstrape.org.pk
	AURAT Foundation	021 – 35830195	www.auratfoundation.com
Peshawar & Quetta	AURAT Foundation	091 – 5704582-83 081 - 2821282	info.gep@af.org.pk
Lahore	AGHS Legal Aid Cell: DASTAK	042 – 5763235	aghs@brain.net.pk
Sialkot	Madadgar Welfare Society	052 – 3561689	www.madadgar.org
Islamabad	National Commission on the Status of Women	051 – 9224875 051 – 9224877	www.ncsw.gov.pk
	Rozan	051 – 2890505 051 – 2890506 051 – 2890507	info@rozan.org
	Sahil	051 – 2260636 051 – 2856950	www.sahil.org

## Appendix B: Special considerations

This is a summary of the most important information that is relevant to comprehensive abortion care providers. (Please see Appendix C: Special contraceptive counseling considerations in the **Contraceptive Services module** for more information on each topic.)

### Young women (ages 10-24)

Physically, young women's clinical needs are similar to those of adult women; however, their life and social circumstances are often very different, requiring care tailored to their unique circumstances, especially concerning counseling and provider attitudes. Providers should make a conscious effort to keep personal beliefs from limiting their ability to give the best care possible to young women.

When a young woman requests postabortion care, she is likely to have carefully considered her options and decisions prior to seeking care. However, young women may want more information on which to base their decision. For the purpose of informed consent, it is important that providers review the woman's medical condition and the options available to her.

Young women should be allowed to make a free, informed decision and that decision should be respected. Because of inadequate or inaccurate information on sexual and reproductive health, counseling may take longer for young women than adults. If the young woman must, by law, notify or get consent from a third party, and she is not eligible for any exemption or alternative, providers should explain this obligation and offer to help her talk to the third party. Even with third party consent requirements for medical treatment, a young woman still has the right to private medical counseling, as counseling is separate (UN 2009).

To determine the decision-making capacity of a young woman seeking reproductive health care, a principle of capability can be used. The principle of capability states, "Young people who understand that they need to protect their reproductive health, and who requests reproductive health services to that end, can be considered capable of receiving reproductive health counseling and services without parental oversight" (Cook and Dickens, 2000). When applied to abortion care for young women, the young woman's capacity is sufficiently demonstrated by her voluntary action to seek and request postabortion care services. The Convention on the Rights of the Child also recognizes that young people's capacities are evolving and not linked directly to chronological age by affirming children's and young people's right to independent decision making in accordance with their capacities (UN 2003).

Stigma around young women's sexuality, consent laws and policies, and cultural and social conditioning by parents create particular challenges in counseling. Providers who want to offer high-quality counseling should be aware of these particular needs, and also recognize their own underlying attitudes toward young women's sexuality which may negatively affect service provision. When possible, young women should be offered counseling from a youth peer provider or from a support person of their choice.

An important counseling topic to cover with young women is sexual violence: “Providers should be aware that sexual coercion or violence, which is common among adolescents in many contexts, may be the cause of the unwanted pregnancy and subsequent abortion. In these cases, they should also remember that the younger the adolescent, the higher the chance that the sexual offender is a close relative or a direct family member, which has implications with regard to confidentiality, the client’s overall care, and referral needs (Postabortion Care Consortium, 2006)”. Also, taking the steps to build and gain trust with young women especially if unmarried will allow her to open up to the provider and share her concerns while allowing the provider to ask about sensitive topics such as abuse and other reproductive health needs such as STI protection and contraception. Providers should seize the opportunity to ask young women about their health needs and provide or refer them to other health-related services.

### **Women with multiple abortions**

If a woman has experienced multiple unwanted pregnancies, the provider can talk with her about why this is occurring. If the reason is that she chooses not to use contraception, some women will not have an explanation as to why they choose this. In some cases, there may be an underlying issue that prevents the woman from adequately protecting herself from unwanted pregnancy, including myths about contraception, coercive sex, abusive sexual relationships or unresolved emotional conflicts. Women with severe emotional issues should be referred to longer-term, professional mental-health services, if available.

### **Women who have experienced violence**

It is likely that providers will encounter women who have experienced sexual violence. Women who have experienced such violence—which includes rape, sexual assault, coercive sex, incest and involuntary sex work—will often experience related health conditions, such as physical injury, sexually transmitted infections (STIs), psychological distress or unplanned pregnancy. Physical or psychological violence during pregnancy may also contribute to miscarriage or the desire for an abortion.

Postabortion care visits may be the only contact that women who have experienced violence have with the health-care system. Providers should develop a standard method for asking all clients about violence in their lives and incorporate those questions into routine counseling. Health workers must be cognizant of their own limitations in assisting women experiencing violence and, whenever possible, refer women to others specialized in addressing these women’s needs.

Special violence-related counseling considerations include:

- An unwanted pregnancy may be the result of rape or incest.
- A spontaneous abortion could have been caused by physical abuse.
- The pregnancy could have been wanted.
- A woman may face further violence if her abortion or use of contraception is not kept confidential.
- A woman may have been forced or coerced into having an unsafe abortion.

### **Women living with HIV**

Women receiving postabortion care who are HIV-positive need specific information, support, counseling, and medical care. If providers have not undergone extensive HIV training, they should refer HIV-positive women to appropriate services, where available. HIV-positive women should be offered information that can help them better understand their condition and improve their own health, as well as the health of their sexual partners and children.

### **Commercial sex workers**

Women's reasons for engaging in sex work, as well as their feelings and perceptions about these activities, vary widely. Women who do sex work have the same rights as women who do not, and should be treated with respect and nonjudgmental attitudes. Providers' assumptions about women's sexual activities, partner choices, types of relationships (intimate versus commercial) or power to negotiate within sexual relationships can negatively affect the counseling session. Providers can be most effective by meeting her needs for health services and referrals.

*HIV infection poses significant threats to the health and longevity of women of childbearing age and their children. Reported rates of HIV transmission from mother to child range from 15% to 45%. These rates can be lowered to less than 5% with the development of routine antiretroviral therapy in areas of the world with access to these medications. Despite the risks, women living with HIV have the same rights as other women to decide whether to carry a pregnancy to term or have an abortion.*

### **Women with cognitive and developmental disabilities and/or mental illness**

Cognitive and developmental disabilities and mental illness vary widely, and some women will need more assistance than others. Women may come to the clinic with their husband, caregiver, parent, friend or relative. While it may be helpful to engage the companion in discussions about the woman's needs, condition, informed consent, choices about care and contraceptive options, it is critical that the provider address the woman directly.

A common misperception is that women with cognitive and developmental disabilities and/or mental illnesses are not sexually active. Many women with these conditions are able to engage in safe, consensual sexual relationships. It is important to note, however, that women with these conditions are at an increased risk for sexual violence and coercive sexual activity, potentially by their caregivers. If sexual violence is suspected, the provider should speak with the woman in private and refer her to appropriate community services.

Communication with a woman who has a cognitive disability may take some extra time and effort on the provider's part.

The woman may or may not be her own guardian, which can affect her ability to give informed consent. If she is able to make decisions about her own care, the provider should make an extra effort to ensure that the woman clearly understands what she is consenting to and what her choices are. Women with cognitive disabilities may be quick to agree or to answer yes before they fully understand a situation.

### **Women in refugee and displaced settings**

Refugee and displaced women may be dealing with many different emotional stresses related to safety and personal-security issues; institutional, societal and personal violence; displacement from family, culture and home; lack of food; lack of access to comprehensive medical care; and insecurity about the future. Many women have been victims of violence during the initial period of displacement, while many others continue to experience violence in their present location. It is important when counseling refugee and displaced women to let them guide the counseling process. The provider must be sensitive to language differences between the provider and the woman, and have a native speaker of the woman's language translate if possible.

### **Women who have experienced genital mutilation**

Providers may encounter women who have undergone female genital mutilation (FGM). As defined by the World Health Organization: "Female genital mutilation, often referred to as 'female circumcision,' comprises all procedures involving partial or total removal of the external female genitalia or other injury to the female genital organs whether for cultural, religious or other non-therapeutic reasons" (WHO, 2000).

Women may not want to bring up the subject of FGM with their provider or may not realize that it will affect their postabortion care. If the woman has undergone genital mutilation, it is very important that the provider use sensitivity when questioning her about it and not assume that all women have the same experience with FGM.

### **Women with advanced gestational age**

Women who present at more advanced gestational ages often have faced multiple barriers that prevented earlier presentation, including not knowing they were pregnant, needing more time to make their decision about seeking care and poor access to health services. Understanding the social and emotional issues that are often a part of PAC treatment at later gestations and providing prompt, sensitive care or referral are an essential part of woman-centered care.

# Contraceptive Services

## Key topics in this module:

- Postabortion contraceptive counseling and method provision
- Service delivery models
- Effective contraceptive counseling
- Medical appropriateness of contraceptive methods following a uterine evacuation
- Emergency contraception (EC)
- Specialized situations for counseling or referrals

## 1.0 Introduction

International organizations, including the World Health Organization (WHO), recognize that access to contraception is a basic human right, fundamental to reproductive and sexual health. All women should receive contraceptive information and be offered counseling for and methods of postabortion contraception, including emergency contraception, before leaving the health-care facility.

A consensus statement by the International Federation of Gynecology and Obstetrics (FIGO), the International Confederation of Midwives (ICM), the International Council of Nurses (ICN), and USAID states that all women should receive family planning counseling and services after spontaneous or induced abortion, irrespective of the procedure used.

The International Planned Parenthood Federation (IPPF) Charter on Sexual and Reproductive Rights includes the right to choose whether or not to marry and to plan a family, and the right to decide whether and when to have children. National laws and health norms in many countries support these rights.

*The term “contraception” is used in this curriculum rather than “family planning.” Many women receiving contraceptive services are trying to avoid getting pregnant as opposed to planning a family. This may be particularly relevant for young women. It is important for providers not to make assumptions about women’s reproductive intentions.*

Key facts about contraceptive care:

- All women receiving postabortion care are at a critical juncture in their reproductive lives and can benefit from compassionate counseling about their contraceptive options.
- About 21 percent of all pregnancies will end in elective, induced abortions. Effective contraceptive methods, where they are made widely available and consistently used, can help women prevent unwanted pregnancies and therefore significantly decrease the rate of abortion.
- Every woman, including young women, presenting for postabortion care should be offered contraceptive counseling and a range of contraceptive methods.
- A study by Ratten in 1972 found that a woman may ovulate as early as 10 days after an incomplete abortion. Because ovulation can occur almost immediately after a uterine evacuation, contraception should be provided immediately to women who want to prevent or delay pregnancy.

This module explains why contraceptive counseling and method provision are critical parts of postabortion care. It also addresses how to successfully counsel women so that those who wish to use contraception will be able to choose a method appropriate to their needs and use that method effectively.

*If a woman comes to a hospital with an incomplete abortion, we’ve already failed once to help her avoid an unwanted or a mistimed pregnancy. If she leaves the facility without having any means of preventing another pregnancy in the future that may not be wanted, we’ve failed her twice. (Cynthia Steele Verme, Postabortion Care (PAC) Consortium)*

## 2.0 Contraceptive counseling and method provision after postabortion care

The goal of contraceptive counseling is to help a woman decide if she wants to prevent pregnancy in the short or long term and assist her in choosing an appropriate contraceptive method. In woman-centered contraceptive counseling, providers focus on each woman’s unique needs, reproductive intentions, life circumstances and clinical condition. WHO’s Medical Eligibility Criteria (MEC) wheel is a good tool which can be used by health care providers to recommend evidence based contraception to women.

([http://www.who.int/reproductivehealth/publications/family\\_planning/9789241547710/en/](http://www.who.int/reproductivehealth/publications/family_planning/9789241547710/en/))

Contraceptive use can promote women’s health and rights by:

- Allowing mothers to achieve spacing between births and a small family size, which improves infant health and saves infant lives;

- Improving women’s quality of life by allowing her to be in control of her reproductive health including the number and timing of her children;
- Helping women avoid unwanted pregnancies, which prevents unnecessary exposure to potential risks during pregnancy and delivery.

Postabortion contraceptive services are effective when they are based on individual women’s needs. Contraceptive counseling should help each woman assess her situation and needs and make an informed decision for herself. Contraceptive use is most effective when the woman has been informed about the advantages, risks, side effects, and likelihood of success of all appropriate options and their alternatives.

### 3.0 Models of service delivery

Contraceptive counseling and method provision can take place at various points and in different ways during abortion services. Service-delivery models include:

- Providers who work in the area of the facility where postabortion care is provided can offer counseling and method provision. This method of service delivery can reduce barriers to access. If contraceptive services cannot be provided in the same area as postabortion care, arrangements should be made to help women easily access the area where contraceptive services are provided.
- Arrangements can be made for staff from another area or facility to come to the postabortion care area to counsel and dispense methods.
- Counseling can be provided at the postabortion care facility with referrals to another facility where women can obtain contraceptive methods.
- Women can go to another clinic for services.
- Community-based contraceptive counseling and method provision can be offered by trained individuals such as village health workers or staff of community-based organizations.

Providing contraceptive services at the same time and in the same location as the abortion care can help ensure that a woman receives a contraceptive method before leaving the facility. If a woman is eligible and has consented to the method, all methods of

#### Healthy timing and spacing of pregnancy

##### *Healthy timing*

- Delay first pregnancy until at least 18 years of age\*
- Avoid pregnancy after 34 years of age

##### *Healthy spacing after a live birth*

- Space pregnancy attempts at least 24 months apart (birth-to-birth interval of at least 33 months)

##### *Healthy spacing after miscarriage or induced abortion*

- Minimum interval to next pregnancy should be at least six months

*Source: World Health Organization, 2006. Report of a WHO Technical Consultation on Birth Spacing.*

*\*Recommendations from WHO, UNICEF and UNFPA on early age pregnancy.*



contraception including IUDs and female sterilization may be started at the same time as a vacuum aspiration. If a woman chooses misoprostol, most methods of contraception can be provided with the medication. After misoprostol, an IUD may be inserted when it is reasonably certain that a woman is no longer pregnant. (Please see Table 7-1 in Section 8.1 for more information.)

#### 4.0 Women's contraceptive needs following postabortion care

Although some women who come for postabortion care may want to become pregnant again soon, some desire contraception to prevent or delay another pregnancy. A provider may begin by asking whether and when the woman wants to become pregnant again and if she desires contraception.

A woman's ability to use contraception successfully may not always be in her control. Providers should empathetically help each woman assess her own situation, consider which method might help her prevent a future unwanted pregnancy, and discuss possible solutions to challenges she may have using contraception.

In some cases, discreet long acting methods that do not require daily adherence such as IUDs or implants may be more effective and may help increase her successful use of contraception. Providers need to avoid blaming women for not preventing past unwanted pregnancies, as this can lead to women's reluctance to seek services in the future. Providers should also be aware of cultural attitudes and beliefs that may influence a woman's use of contraception, particularly young women.

#### 4.1 Contraceptive failure

Providers will encounter women who have experienced contraceptive failure. Contraceptive failure happens for several reasons:

- Failure of the contraceptive method:
  - No method is 100% effective. Even when a modern method of contraception is used correctly and consistently, some women will become pregnant.
- Failure to use the method or failure to use it correctly or consistently for various reasons such as:
  - Forgetting to use a method consistently;
  - Not being able to afford contraceptives on a regular basis;
  - Stopping use due to unwanted side effects or misunderstandings about effects on fertility or health;
  - Disapproval of husband, mother-in-law, other family members, religious leaders or other influential people;

#### ***Providers must ensure that every woman receiving abortion-related care knows:***

- *Ovulation, and thus pregnancy, can occur almost immediately after a uterine evacuation;*
- *In general, all methods of contraception can be used immediately following a uterine evacuation;*
- *When she can obtain contraceptive services and methods including emergency contraception (EC).*

- Sex was non-consensual;
- Concerns about being stigmatized due to cultural attitudes that equate contraceptive use with promiscuity.

There are also health-system-related failures that can result in women not being able to access or correctly use contraceptive methods, including:

- The provider did not adequately explain how to use the method;
- National reproductive health policies limit access to contraception for certain women, such as young or unmarried women;
- Contraceptive methods are too expensive;
- Family-planning clinics do not reliably stock women's preferred methods;
- Contraceptive service locations and times are not convenient;
- Contraceptive-service protocols limit re-supply; for example, dispensing only a one-month supply at a time.

In facilities where contraceptive services are not offered, providers must ensure that every woman receiving postabortion care knows:

- Ovulation, and thus pregnancy, can occur almost immediately after a uterine evacuation;
- In general, all methods of contraception can be used immediately following a uterine evacuation;
- Where she can obtain contraceptive services and methods, including emergency contraception.

## **5.0 Rights to privacy, confidentiality and informed choice**

Privacy and confidentiality are essential, especially in postabortion care settings. Women should receive counseling in a private area where they are not seen or overheard by others. The provider should assure the woman that the discussion is confidential. Providers should follow professional protocols that protect confidentiality. This includes not releasing the woman's information without her consent and not discussing her situation in the presence of others.

All women, including young women, have the right to make a free and informed choice about the contraceptive method she will use. Acceptance of contraception or of a specific method should never be a prerequisite for obtaining postabortion care. Free and informed choice means that a woman chooses a method voluntarily, without coercion or pressure. It requires that she have a variety of methods to choose from and a clear understanding of the benefits and risks of each method.

## **6.0 Involvement of husbands**

The inclusion of husbands in contraceptive counseling can increase the effectiveness of the counseling. Husbands' support of contraception is a strong predictor of contraceptive use.

Counseling husbands can increase their awareness and use of male contraceptive methods, such as male condoms and vasectomy.

If the woman's husband wants to be included in the contraceptive counseling process, the provider should first meet alone with the woman to determine if she wants the husband involved. If a woman does not want her husband involved, she should be counseled and given the method privately and no information from the visit should be shared with her husband.

If the woman's husband does not approve of contraception but the woman still wants to use it, the provider can help her select a method that does not require her husband's cooperation, such as an injectable, implant or IUD. The provider should also discuss possible consequences, such as violence, if the woman's husband learns of her contraceptive use. If appropriate, the provider should help the woman explore how she would protect herself in such an event and should provide referrals to appropriate services. (Please see Contraceptive Services and the Informed Consent, Information and Counseling modules).

## **7.0 Essential steps for contraceptive counseling**

A provider who counsels effectively does more than describe the various contraceptive methods available; he or she establishes trust with the woman, comes to understand her needs and tailors the counseling session to meet those needs. Contraceptive counseling requires an open exchange of information that can only occur in an atmosphere of mutual respect. (Please see the Informed Consent, Information and Counseling module).

The following steps have been adapted from the GATHER technique, a widely used approach in contraceptive services.

### *Greet and establish rapport*

- Secure a private space to talk, greet the woman in a friendly way, speak directly to her and demonstrate interest and concern.
- Ask if it is an appropriate time to discuss contraception, assure her that the conversation will be kept confidential and ask if she wants her husband present.

### *Ask the woman*

- Ask the woman about her needs. Using open-ended questions, discuss the factors that led to the abortion and determine if the pregnancy was unplanned.
- If she was using contraception, ask her to explain how failure occurred. Explain human reproduction, if necessary. Some women who seek an abortion may not fully understand basic information on how they became pregnant or how contraception prevents pregnancy. This may be particularly true for young women.
- Find out if she desires to delay or prevent future pregnancy:
  - Some women may not be interested in delaying pregnancy. For these women, contraceptive counseling and information on the benefits of spacing children may still be useful for future reference, or if a delay in pregnancy is medically recommended.

- Many women desire contraception to prevent or delay another pregnancy.
- Consider the woman's clinical condition and her personal situation. (Please see Appendix A: Individual Factors and Counseling Recommendations and Rationales for more information.)

*Tell the woman about characteristics of available methods*

- Determine which contraceptive methods are available and accessible at the facility and in the community.
- Explain characteristics, side effects and effectiveness of the methods available, and direct her to accessible places to obtain them.

*Help the woman choose her method*

- Support the woman in selecting the contraceptive method that best suits her and her husband.
- Solicit follow-up questions, explaining the characteristics of different methods and exploring resupply issues, including where contraceptives may be available in her community.
- Discuss potential barriers to successful use of contraception and explore ways to overcome them.

*Explain how the method works*

- Ensure she understands how the method works.
- Help her develop a plan for continued use.

*Return for follow-up care and refer to other resources*

- Encourage her to return if she has concerns or problems with her method, the method becomes unacceptable, if she wants to change methods, if she needs re-supply or if she wishes to stop using contraception.
- Discussions about contraception may reveal other factors affecting a woman's sexual and reproductive health, such as violence or commercial sex work.
- Providers should have resource lists available.

## **8.0 Medical eligibility for contraceptive use after a uterine evacuation**

When providing contraception to a woman, her medical eligibility for each method must be considered. In general, all modern contraceptive methods can be used by women, including young women, immediately following uterine evacuation, provided that:

- There are no severe complications requiring further treatment.
- The woman receives adequate counseling and gives informed consent.
- The provider screens for any precautions for using a particular contraceptive method.

There are some notes of caution:

- Women should not have sexual intercourse until any medical complications are resolved and their chosen contraceptive method becomes effective.
- Fertility-awareness based methods should only be started after the resumption of regular menses.
- Some medical conditions require a delay in the use of certain methods. Another contraceptive method should be offered to the woman for use in the interim.

Based on WHO data, the following section discusses which methods are appropriate or inappropriate for various clinical conditions. (Please see Appendix B: Guidelines for Selection of Contraception by Method). The contraceptive methods referred to include:

- Barrier methods such as male and female condoms, spermicides, diaphragms and cervical caps;
- Hormonal methods such as oral contraceptives, injectables, implants, skin patches and vaginal rings;
- Intrauterine methods such as IUDs and intrauterine systems (IUS);
- Fertility awareness-based methods such as basal body temperature and calendar methods;
- Emergency contraception, which must be used within five days after unprotected intercourse and includes a specific regimen of contraceptive pills or insertion of an IUD;
- Surgical methods such as male and female sterilization.

## 8.1 Uncomplicated uterine evacuation with misoprostol

Medical eligibility after misoprostol is not different from that of vacuum aspiration. Most modern hormonal contraceptive methods can be used immediately with misoprostol, provided that there are no contraindications. This recommendation is based on expert opinion. Delaying provision of contraceptive methods puts women at risk of unintended pregnancy. A woman who wants contraception should be provided her preferred method as soon as possible.

### **Long-acting reversible contraceptives (LARC)**

*LARC are contraceptive methods that include:*

- *Copper intrauterine devices*
- *Progestogen-only intrauterine systems*
- *Progestogen-only subdermal implants*

*LARC have been found to be more effective in preventing future pregnancies and have higher satisfaction than pills for both adult and young women, leading to longer continued use.*

*Because unintended pregnancy occurs when women stop or switch methods, satisfaction and continuation are important strengths of IUDs and implants as contraceptive methods.*

Table 7-1: When to start contraception after misoprostol

Contraceptive method	Initiation timing
Oral contraceptive pills, contraceptive ring and patch	With misoprostol
Implant	With misoprostol
Injection	With misoprostol
IUD	As soon as reasonably sure woman is no longer pregnant
Sterilization	As soon as reasonably sure woman is no longer pregnant
Fertility awareness-based methods	Should only be started after the resumption of regular periods

## 8.2 Uncomplicated vacuum aspiration

All modern contraceptive methods can be used immediately.

## 8.3 Vacuum aspiration with complications

In cases where an infection is evident or presumed, the provider should advise the woman to avoid intercourse until the infection is resolved or ruled out. All methods of contraception can be given after a uterine evacuation complicated by an infection, except for the intrauterine device and female sterilization. An intrauterine device may be inserted or sterilization performed once the infection is resolved.

While not medical eligibility contraindications, providers need to take genital injuries or excessive blood loss into consideration. Genital injury includes uterine perforations, cervical tears, vaginal trauma and lacerations. These injuries may require a delay in the use of certain contraceptive methods. Methods that may be temporarily restricted include female sterilization, IUD, IUS, spermicides and barrier methods other than the male condom.

Excessive blood loss may require a delay in the use of female sterilization and IUDs, depending on the severity of the loss. For sterilization, delay is recommended if laboratory tests or clinical signs indicate anemia.

## 9.0 Emergency contraception

Emergency contraception is a particularly important option for preventing pregnancy after unprotected intercourse or contraceptive failure and is often easily available in pharmacies and chemist shops. For women receiving postabortion care, providing EC pills in advance as a back-up method in case of contraceptive failure may help prevent future unwanted pregnancies. The use of EC will not terminate or interfere with a pregnancy once it is established.

There are two types of EC:

- Intrauterine device (IUD): When inserted within five days after unprotected intercourse, a copper IUD is 99 percent effective in preventing pregnancy.
- Emergency contraceptive pills (ECPs): These pills are 75 to 95 percent effective when used within five days after unprotected intercourse.
- To be most effective, ECPs should be started as soon as possible after unprotected intercourse but may be taken up to 5 days after unprotected intercourse.
- Although either progestin-only pills (POPs) or combined estrogen-progestin oral pills (COCs) may be used, POPs are more effective and produce fewer side effects.
- When taken within 24 hours of unprotected intercourse, progestin-only ECPs have been found to reduce the risk of pregnancy by 95 percent.
- When taken within 72 hours of unprotected intercourse, ECPs that contain progestin-only reduce the risk of pregnancy by 89 percent, while ECPs that contain both estrogen and progestin reduce the risk of pregnancy by 75 percent.

### Emergency contraception pills

*In some settings, pills specifically packaged for EC are available. Where packaged ECPs are not available, taking a specific dose of commonly packaged oral contraceptives is acceptable. Recommended dosages depend on the formulation of the particular pills used. The following are examples of ECP regimens:*

- *POPs: Single dose of 1.5mg of levonorgestrel taken within five days of unprotected intercourse. In countries where pills containing 1.5mg of levonorgestrel are not available, two pills of 0.75mg can be taken together. Other POPs with levonorgestrel can also be used but, depending on the pill composition, women will need to take the number of pills equal to 1.5mg of levonorgestrel.*
- *COCs: Two doses of 0.1mg (100mcg) of ethinyl estradiol plus either 0.5mg of levonorgestrel or 1.0mg of norgestrel taken 12 hours apart but within 120 hours after unprotected intercourse.*

*Women should be advised that the progestin-only regimen has the highest effectiveness and fewest side effects.*

## 10.0 Special contraceptive counseling considerations

There are certain specialized considerations providers should keep in mind for the following women and issues:

- Young women
- Multiple abortions

- Violence
- Living with HIV
- Women engaged in sex work
- Women with cognitive and developmental disabilities and mental illness
- Refugees and displaced persons
- Female genital mutilation

Information is provided in Appendix C: Special Contraceptive Counseling Considerations, which covers how providers can meet the specific contraceptive needs for women with in these circumstances.

## 11.0 Summary

- Every woman, including young women, receiving postabortion care should be offered contraceptive counseling and, if she desires, a contraceptive method.
- Contraceptive services support the basic human right to decide whether and when to have children. Women receiving contraceptive services have a right to privacy, confidentiality and informed choice.
- To be effective, providers must establish trust, strive to understand a woman's contraceptive preferences and needs, and tailor the counseling session to meet those needs.
- There are several possible service-delivery models for providing contraceptive services. Providing contraceptive services at the same time and in the same location as the abortion care can help ensure that a woman receives a contraceptive method before leaving the facility.
- Women receiving postabortion care may have a history of contraceptive use that includes failure of the contraceptive, incorrect use or non-use of their chosen method or failure of the health system to provide their contraceptive of choice.
- Inclusion of husbands in contraceptive counseling may increase the effectiveness of the counseling, but should only be done if the woman, during a one-to-one conversation with the provider, indicates that she wants her husband involved. If not, she should be counseled and given the method privately and no information from the visit should be shared with her husband.
- Providers need to be knowledgeable about the range of contraceptive methods and consider each woman's medical eligibility for various methods, including EC.
- Providers should understand that women may have special situations in their lives that will affect their contraceptive needs and use, and should be prepared to address those situations.



## References

- Abdel-Tawah, N., Huntington, D., Hassan, E. O., Youssef, H., & Nawar, L. (1999). Effects of husband involvement on postabortion patients' recovery and use of contraception in Egypt. In D. Huntington & N. J. Peterson (Eds.), *Postabortion care: Lessons from operations research*. New York, NY: The Population Council.
- Alan Guttmacher Institute (AGI). (1999). *Sharing responsibility: Women, society & abortion worldwide*. New York, NY: The Alan Guttmacher Institute.
- Bednarek, P. H., Creinin, M. D., Reeves, M. F., Cwiak, C., Espey, E., & Jensen, J. T. (2011). Immediate versus delayed IUD insertion after uterine aspiration. *New England Journal of Medicine*, 364(23), 2208-2217.
- Benson, J., Leonard, A. H., Winkler, J., Wolf, M., & McLaurin, K. E. (1992). Meeting women's needs for post-abortion family planning: Framing the questions. *Issues in Abortion Care*, 2.
- Billings, D. L., Crane, B. B., Benson, J., Solo, J., & Fetters, T. (2007). Scaling up a public health innovation: A comparative study of post-abortion care in Bolivia and Mexico. *Social Science & Medicine*, 64(11), 2210-2222.
- Bongaarts, J., & Westoff, C. F. (2000). The potential role of contraception in reducing abortion. *Studies in Family Planning*, 31(3), 193-202.
- Center for Reproductive Rights (CRR). (2008). *Bringing rights to bear anew: 2008 update*. Retrieved from <http://reproductiverights.org/en/press-room/bringing-rights-to-bear-anew-2008-update>.
- Centers for Disease Control and Prevention (CDC). (2001). Appendix B: Management of occupational blood exposures. *Morbidity and mortality weekly report*, 50(RR11), 45-46.
- Cheng, L., Che, Y., & Gülmezoglu, A. M. (2012). Methods of emergency contraception. *Cochrane Summaries*.
- Corbett, M. R., & Turner, K. L. (2003). Essential elements of postabortion care: Origins, evolution and future directions. *International Family Planning Perspectives*, 29(3), 106-111.
- Curtis, C., Huber, D., & Moss-Knight, T. (2010). Postabortion family planning: Addressing the cycle of repeat unintended pregnancy and abortion. *International Perspectives on Sexual and Reproductive Health*, 36(1), 44-48.
- Curtis, K. M., Mohllajee, A. P., & Peterson, H. B. (2006). Regret following female sterilization at a young age: A systematic review. *Contraception*, 73(2), 205-210.
- Dinerman, L. M., Wilson, M. D., Duggan, A. K., & Joffe, A. (1995). Outcomes of adolescents using levonorgestrel implants vs. oral contraceptives or other contraceptive methods. *Archives of Pediatrics and Adolescent Medicine*, 149(9), 967-972.
- Diouf, K., & Nour, N. (2013). Female genital cutting and HIV transmission: Is there an association? *American Journal of Reproductive Immunology*, 69 Suppl 1, 45-50.
- Family Health International (FHI). (2000). *Contraception after pregnancy. Contraceptive Technology Update Series, October 2000*. Durham, NC: FHI.
- Ferreira, A. L., Souza, A. I., Lima, R. A., & Braga, C. (2010). Choices on contraceptive methods in post-abortion family planning clinic in the northeast Brazil. *Reproductive Health*, 7(5).
- Huntington, D., Hassan, E. O., Attallah, N., Toubia, N., Naguib, M., & Nawar, L. (1995). Improving the medical care and counseling of postabortion patients in Egypt. *Studies in Family Planning*, 26(6), 350-362.
- International Consortium for Emergency Contraception (ICEC). (2012). *Emergency Contraceptive Pills: Medical and Service Delivery Guidelines* (3rd ed.). New York, NY: ICEC.
- International Federation of Gynecology and Obstetrics (FIGO), International Confederation of Midwives (ICM), International Council of Nurses (ICN), & United States Agency for International Development (USAID). (2009). *Family planning: A key component of post abortion care. Consensus statement*. Retrieved from [http://transition.usaid.gov/our\\_work/global\\_health/pop/techareas/pac/fp\\_component.pdf](http://transition.usaid.gov/our_work/global_health/pop/techareas/pac/fp_component.pdf).
- Johnson, B. R., Ndhlovu, S., Farr, S. L., & Chipato, T. (2002). Reducing unplanned pregnancy and abortion in Zimbabwe through postabortion contraception. *Studies in Family Planning*, 33(2), 195-202.

- Leonard, A. H., & Ladipo, O. A. (1994). Postabortion family planning: Factors in individual choice of contraceptive methods. *Advances in Abortion Care*, 4(2).
- Mason, K., & Pilyman, L. (1992). Not for women only: Child spacing clubs for Malawian men. *AVSC News*, 30(4).
- McDougall, J., Fetters, T., Clark, K. A., & Rathavy, T. (2009). Determinants of Contraceptive Acceptance Among Cambodian Abortion Patients. *Studies in Family Planning*, 40(2), 123-132.
- Peipert, J. F., Zhao, Q., Allsworth, J. E., Petrosky, E., Madden, T., Eisenberg, D., & Secura, G. (2011). Continuation and satisfaction of reversible contraception. *Obstetrics & Gynecology*, 117(5), 1105-1113.
- Ratten, G. J. (1972). Resumption of ovulation after incomplete abortion. *The Australian and New Zealand Journal of Obstetrics and Gynaecology*, 12(4), 217-219.
- Roberts, H., Silva, M., & Xu, S. (2010). Post abortion contraception and its effect on repeat abortions in Auckland, New Zealand. *Contraception*, 82(3), 260-265.
- Rosenstock, J. R., Peipert, J. F., Madden, T., Zhao, Q., & Secura, G. M. (2012). Continuation of reversible contraception in teenagers and young women. *Obstetrics and Gynecology*, 120(6), 1298-1305.
- Ross, J. A., Rich, M., & Molzan, J. P. (1989). *Management strategies for family planning programs*. New York, NY: Columbia University.
- Salter, C., Johnston, H. B., & Hengen, N. (1997). Care for postabortion complications: Saving women's lives. *Population Reports, Series L* (10).
- Scholes, D., LaCroix, A. Z., Ichikawa, L. E., Barlow, W. E., & Ott, S. M. (2005). Change in bone mineral density among adolescent women using and discontinuing depot medroxyprogesterone acetate contraception. *Archives of Pediatrics and Adolescent Medicine*, 159(2), 139-144.
- Solo, J., Billings, D. L., Aloo-Obunga, C., Ominde, A., & Makumi, M. (1999). Creating linkages between incomplete abortion treatment and family planning services in Kenya. *Studies in Family Planning*, 30(1), 17-27.
- Stevens-Simon, C., Kelly, L., & Kulick, R. (2001). A village would be nice but...it takes a long-acting contraceptive to prevent repeat adolescent pregnancies. *American Journal of Preventive Medicine*, 21(1), 60-65.
- Task Force on Postovulatory Methods of Fertility Regulation (TFPMFR). (1998). Randomised controlled trial of levonorgestrel versus the Yuzpe regimen of combined oral contraceptives for emergency contraception. Task Force on Postovulatory Methods of Fertility Regulation. *Lancet*, 352(9126), 428-433.
- Templeman, C. L., Cook, V., Goldsmith, L. J., Powell, J., & Hertweck, S. P. (2000). Postpartum contraceptive use among adolescent mothers. *Obstetrics and Gynecology*, 95(5), 770-776.
- Tolaymat, L. L., & Kaunitz, A. M. (2007). Long-acting contraceptives in adolescents. *Current Opinion in Obstetrics and Gynecology*, 19(5), 453-460.
- Tripney, J., Schucan, B. K., Kwan, I., & Kavanagh, J. (2010). *The impact of post-abortion care family planning counseling and services in low-income countries: a systematic review of the evidence (Technical report)*. London, England: University of London.
- Trussell, J. (2009). Choosing a Contraceptive: Efficacy, Safety and Personal Considerations. In R. A. Hatcher, J. Trussell, A. L. Nelson, W. Cates Jr., F. H. Stewart & D. Kowal (Eds.), *Contraceptive Technology* (19 ed.). New York, NY: Ardent Media.
- Turner, K. L., Borjesson, E., Huber, A., & Mulligan, C. (2011). *Abortion care for young women: A training toolkit*. Chapel Hill, NC: Ipas.
- Upadhyay, U. D., & Robey, B. (1999). Why family planning matters. *Population Reports, Series J* (49).
- Winner, B., Peipert, J. F., Zhao, Q., Buckel, C., Madden, T., Allsworth, J. E., & Secura, G. M. (2012). Effectiveness of long-acting reversible contraception. *New England Journal of Medicine*, 366(21), 1998-2007.
- Wolf, M., & Benson, J. (1994). Meeting women's needs for post-abortion family planning. Report of a Bellagio Technical Working Group. *International Journal of Gynecology & Obstetrics*, 45 Suppl, S1-33.
- World Health Organization (WHO). (1997). *Post-abortion family planning: A practical guide for programme managers*. Geneva: World Health Organization.

World Health Organization. (2008). *Selected practice recommendations for contraceptive use, update to second edition*. Geneva: World Health Organization.

World Health Organization. (2009). *Medical eligibility criteria for contraceptive use* (pp. 1 online resource (121 p.)). Retrieved from [http://whqlibdoc.who.int/publications/2010/9789241563888\\_eng.pdf](http://whqlibdoc.who.int/publications/2010/9789241563888_eng.pdf)

World Health Organization. (2010). *Adolescent job aid: A handy desk reference tool for primary level health workers*. Geneva: World Health Organization.

World Health Organization. (2012). *Emergency contraception*. Geneva: World Health Organization.

**Appendix A: Individual factors and counseling recommendations and rationales\***

If the woman...	Recommendations	Rationales
Does not want to be pregnant soon	Consider all reversible methods.	Seeking an abortion usually suggests that the woman does not want to be pregnant at this time.
Is under stress or in pain	Consider all reversible methods. Do not encourage use of permanent methods at this time. Provide referral for continued contraceptive care.	Stress and pain interfere with making free, informed decisions, and this is not usually a good time for a woman to make a permanent decision.
Was using a contraceptive method when she became pregnant	Assess why contraception failed and what problems the woman might have had using the method effectively. Help the woman choose a method that she will be able to use effectively. Ensure that she understands how to use the method, get follow-up care and resupply, discontinue use and change methods.	Method failure, unacceptability, ineffective use or lack of access to supplies may have led to the unwanted pregnancy. These factors may still be present and may lead to another unwanted pregnancy.
Has stopped using a method, but does not want to become pregnant soon	Assess why the woman stopped using contraception, including side effects or lack of access to resupply. Help the woman choose a method that she will be able to use effectively. Make sure she understands how to use the method, get follow-up care and resupply, discontinue use and change methods.	Unacceptability or lack of access may have led to ceasing use of contraception. These factors may still be present and may lead to another unwanted pregnancy.
Is young	Consider all methods including long-acting methods like the intrauterine device or implants.	Young women are eligible for all forms of contraception, similar to older women.
Has a husband who is unwilling to use condoms or will prevent use of another method	If the woman wishes, include her husband in counseling. Protect the woman's confidentiality in all instances, even if she does involve her husband. Discuss methods that the woman can use without her husband's knowledge, such as injectables, IUDs or implants. Do not recommend methods that the woman will not be able to use effectively.	In some instances, involving the male in counseling will lead to his use of and support for contraception; however, if the woman, for whatever reasons, does not want to involve a husband, her wishes should be respected.
Wants to become pregnant soon	Do not try to persuade her to accept a method. Provide information or a referral if the woman needs other reproductive-health services.	Women accessing postabortion care may want to become pregnant again soon.

\* Note that more than one factor may apply. Adapted from Leonard and Ladipo, 1994.

## Appendix B: Guidelines for Selection of Contraception by Method

Method	Timing After Uterine Evacuation*	Advantages	Remarks
<b>Non-Fitted Barriers</b> Latex and vinyl male/female condoms; <sup>†</sup> vaginal sponge and suppositories such as foaming tablets, jelly or film	May be used immediately after postabortion care with vacuum aspiration or misoprostol	<ul style="list-style-type: none"> <li>No method-related health risks</li> <li>Inexpensive</li> <li>Good interim method if initiation of another method must be postponed</li> <li>No medical supervision required</li> <li>Latex and vinyl condoms provide protection against RTIs and STIs (HBV and HIV)</li> <li>Easily discontinued</li> <li>Effective immediately</li> </ul>	<ul style="list-style-type: none"> <li>In typical use, less effective than IUD or hormonal methods</li> <li>Requires use with each incident of intercourse</li> <li>Requires continued motivation</li> <li>Resupply must be available</li> <li>May interfere with intercourse</li> </ul>
<b>Fitted Barriers Used With Spermicides</b> Diaphragm or cervical cap with foam or jelly	<ul style="list-style-type: none"> <li>Diaphragm can be fitted immediately after postabortion care with vacuum aspiration or misoprostol</li> <li>Delay fitting cervical cap until bleeding has stopped and uterus has returned to pre-pregnancy size</li> </ul>	<ul style="list-style-type: none"> <li>No method-related health risks</li> <li>Inexpensive</li> <li>No medical supervision required</li> <li>Some protection against RTIs and STIs (HBV and HIV)</li> <li>Easily discontinued</li> <li>Effective immediately</li> </ul>	<ul style="list-style-type: none"> <li>Less effective than IUD or hormonal methods</li> <li>Requires use with each incident of intercourse</li> <li>Requires continued motivation</li> <li>Resupply of spermicides must be available</li> <li>Associated with urinary-tract infections in some users</li> <li>Requires fitting by trained service provider</li> </ul>
<b>Oral Contraceptives</b> Combined and progestin-only	May be used immediately after postabortion care with vacuum aspiration or given with misoprostol	<ul style="list-style-type: none"> <li>Highly effective Available in some settings in community pharmacy or chemist shops</li> <li>Can be started immediately, even if infection is present</li> <li>Can be provided by non-physicians</li> <li>Does not interfere with intercourse</li> </ul>	<ul style="list-style-type: none"> <li>Requires continued motivation and daily use</li> <li>Resupply must be available</li> <li>No protection against STIs/HIV</li> <li>Effectiveness may be lowered with long-term use of certain medications, including rifampin, dilantin and griseofulvin</li> </ul>

\*This information applies to methods after first-trimester abortion.

† Male and female condoms are the only methods that provide protection against transmission of STI/HIV; they can be used in conjunction with all other methods.

**Appendix B: Guidelines for Selection of Contraception by Method (continued)**

Method	Timing After Uterine Evacuation*	Advantages	Remarks
<b>Emergency Contraceptive Pills</b>	May be used immediately after postabortion care	<ul style="list-style-type: none"> <li>• Important backup method when contraception fails (for example, condom breaks), when no method is used or when sex is forced</li> <li>• Available in some settings in community pharmacy or chemist shops</li> </ul>	<ul style="list-style-type: none"> <li>• Providing emergency contraceptive pills in advance as a backup method may help prevent future unwanted pregnancies</li> <li>• No protection against STIs/HIV</li> <li>• Generally less effective than other contraceptive methods</li> <li>• May have side effects such as nausea and vomiting</li> </ul>
<b>Vaginal Rings</b>	May be used immediately after postabortion care with vacuum aspiration or misoprostol	<ul style="list-style-type: none"> <li>• Highly effective</li> <li>• Can be provided by nonphysicians</li> <li>• Does not require daily attention from user; stays in vagina for three weeks once inserted</li> <li>• Can be inserted by user</li> <li>• Available in some settings in community pharmacy or chemist shops</li> <li>• Highly effective</li> </ul>	<ul style="list-style-type: none"> <li>• Resupply must be available</li> <li>• Effectiveness may be lowered with long-term use of certain medications such as rifampin, dilantin and griseofulvin</li> </ul>
<b>Skin Patches</b>	May be used immediately after postabortion care with vacuum aspiration or misoprostol	<ul style="list-style-type: none"> <li>• Can be started immediately, even if infection is present</li> <li>• Can be provided by nonphysicians</li> <li>• Available in some settings in community pharmacy or chemist shops</li> <li>• Does not interfere with intercourse</li> <li>• Does not require daily attention from user; applied once a week</li> <li>• Applied by user</li> </ul>	<ul style="list-style-type: none"> <li>• Resupply must be available</li> <li>• Effectiveness may be lowered with long-term use of certain medications such as rifampin, dilantin and griseofulvin</li> <li>• For the first cycle, if applied later than 24 hours after menstrual period starts, back-up method must be used for seven days</li> </ul>

*\*This information applies to methods after first-trimester abortion.*

**Appendix B: Guidelines for Selection of Contraception by Method (continued)**

Method	Timing After Uterine Evacuation*	Advantages	Remarks
<b>Progestin-Only Injectables</b> (DMPA, NET-EN)	May be given immediately after postabortion care with vacuum aspiration or misoprostol	<ul style="list-style-type: none"> <li>• Highly effective</li> <li>• Can be started immediately, even if infection is present</li> <li>• Can be provided by non-physician</li> <li>• Does not interfere with intercourse</li> <li>• Not user-dependent, except for remembering to get the injection every two or three months</li> <li>• No supplies needed by user</li> </ul>	<ul style="list-style-type: none"> <li>• May cause irregular bleeding, especially amenorrhea; excessive bleeding may occur in rare instances</li> <li>• Delayed return to fertility after stopping use</li> <li>• Must receive injections every two or three months</li> <li>• In many settings, must go to the clinic for resupply</li> </ul>
<b>Combined Injectables</b>	May be given immediately after postabortion care with vacuum aspiration or misoprostol	<ul style="list-style-type: none"> <li>• Highly effective</li> <li>• Can be started immediately, even if infection is present</li> <li>• Can be provided by non-physician</li> <li>• Does not interfere with intercourse</li> <li>• Not user-dependent, except for remembering to get the injection every two or three months</li> <li>• No supplies needed by user</li> </ul>	<ul style="list-style-type: none"> <li>• May cause heavy and/or irregular bleeding initially, especially for the first few months; then regular monthly bleeding usually resumes</li> <li>• Delayed return to fertility</li> <li>• Must receive injections every two or three months</li> <li>• In many settings, must go to the clinic for resupply</li> </ul>
<b>Progestin-Only Implants</b>	May be inserted immediately after postabortion care with vacuum aspiration or misoprostol	<ul style="list-style-type: none"> <li>• Highly effective</li> <li>• Long-term contraception</li> <li>• Immediate return to fertility on removal</li> <li>• Does not interfere with intercourse</li> <li>• No supplies needed by user</li> </ul>	<ul style="list-style-type: none"> <li>• May cause irregular bleeding, especially spotting, or amenorrhea</li> <li>• Trained provider required to insert and remove</li> <li>• Cost-effectiveness depends on how long used</li> </ul>

*\*This information applies to methods after first-trimester abortion.*

**Appendix B: Guidelines for Selection of Contraception by Method (continued)**

Method	Timing After Uterine Evacuation*	Advantages	Remarks
<b>IUD/IUS<sup>‡</sup></b>	IUD/IUSs can be inserted after uncomplicated vacuum aspiration. After misoprostol, IUD/IUS may be inserted as soon as it is reasonably sure a woman is no longer pregnant.	<ul style="list-style-type: none"> <li>• Highly effective</li> <li>• Long-term contraception; effective for five to 12 years, depending on the type</li> <li>• Immediate return to fertility following removal</li> <li>• Does not interfere with intercourse</li> <li>• No supplies needed by user</li> <li>• Only one follow-up visit needed unless there are problems</li> </ul>	<ul style="list-style-type: none"> <li>• May increase menstrual bleeding and cramping during the first few months</li> <li>• Hormone treated IUD/IUS can decrease bleeding or cause amenorrhea. They are associated with secondary health benefits. Complications can include uterine perforation during insertion (rare), and expulsion.</li> <li>• May increase risk of pelvic inflammatory disease (PID) and subsequent infertility for women at risk for RTIs and STIs (HBV and HIV)</li> <li>• Trained provider required to insert and remove</li> </ul>
<b>Female Voluntary Sterilization (FVS)</b>	FVS can be performed after uncomplicated vacuum aspiration. After misoprostol, FVS may be performed as soon as it is reasonably sure a woman is no longer pregnant.	<ul style="list-style-type: none"> <li>• Permanent method</li> <li>• Highly effective</li> <li>• No change in sexual function</li> <li>• No long-term side effects</li> <li>• Immediately effective</li> </ul>	<ul style="list-style-type: none"> <li>• Adequate counseling and fully informed consent are required before VS procedures</li> <li>• Slight possibility of surgical complications</li> <li>• Requires trained staff and appropriate equipment</li> </ul>
<b>Fertility Awareness</b>	May use method after first normal period has returned. Only for use in a women with a history of regular periods.	<ul style="list-style-type: none"> <li>• No cost associated with method</li> <li>• No method-related health risks</li> <li>• No medical supervision required</li> <li>• Easily discontinued</li> <li>• Effective immediately</li> </ul>	<ul style="list-style-type: none"> <li>• Unreliable immediately after abortion</li> <li>• Alternative methods recommended until resumption of normal cycle</li> <li>• Requires extensive instruction and counseling</li> <li>• Requires continued motivation and a thorough understanding by the woman and her husband of how to use the method</li> <li>• Does not protect against STIs/HIV</li> </ul>

*Adapted from: Benson et al., 1992; WHO, 2010b*

*\* This information applies to methods after first-trimester uterine evacuation.*

*‡ See Section 9.0 for information on emergency contraceptive IUDs*



## Appendix C: Special Contraceptive Counseling Considerations

(Please see Appendix A: Special Considerations in the Informed Consent, Information and Counseling module for more information.)

### Young women (ages 10-24)

Young women's contraceptive needs vary greatly. A young married woman with one child who wants to avoid having a second may have different considerations than a young woman who may be at higher risk for STIs, including HIV. Some young women may want to become pregnant immediately after postabortion care and do not require contraception. When providing contraceptive counseling and services, it is important to ask what the young woman's immediate and longer-term reproductive plans are and then provide appropriate counseling.

Contraceptive counseling should also include information on fertility awareness, by asking what the client knows about her menstrual cycle and fertility and building on that to educate her about the fertile and infertile points in her cycle. Fertility awareness-based methods are not recommended for young women with erratic or irregular menstrual cycles. Young women may have concerns about the safety or efficacy of contraceptive methods, which may be based on misinformation. They may not know how pregnancy occurs or is prevented.

For example, they may have heard that pregnancy won't occur if they have intercourse in certain positions, in water or during menstruation, or believe that contraception will cause future permanent infertility. Because of misinformation like this, it is important that providers explain how a contraceptive works, including efficacy, potential side effects such as weight gain or breast tenderness and their incidence, and the long-term clinical implications of any such side effects. Providers can ask indirect questions such as "What are some things your friends say about how you can and can't get pregnant?" and "What are some things you heard about this method?" to find out whether a young woman is misinformed.

Contraceptive counseling should be reality-based. That is, it should begin by uncovering and addressing what clients believe and whether or not it is accurate, in order to avoid the method's discontinuation. To assist clients with weighing the potential risks against the benefits of a contraceptive method it may be helpful to compare the risks of a given method to other non-reproductive health medical procedures. Providers should also learn from the young woman what barriers she may face in using different contraceptive methods and help the young woman identify the most appropriate option for her. A young woman's privacy needs can also influence her selection of contraceptive method; for example, injectables, implants or an intrauterine device may suit a young woman with high privacy needs, even if her preferred method might otherwise be something else.

Making a larger range of contraceptive methods available is correlated with increased acceptance of a method among young and adult women. In addition to her method of choice, the young woman should be offered to leave the facility with at least one dose of contraceptive pills (ECPs), in case of an accident or contraceptive failure.

The following information should also be presented when discussing contraception with young women:

### *Medical eligibility for young women*

Clinical eligibility guidelines for postabortion contraceptives for young women are the same as for adult women. Three methods have implications for young women that bear additional discussion.

### *Sterilization*

There is no clinical contraindication for sterilization in young women. However, women under the age of 30 are significantly more likely to experience regret after sterilization. During counseling, providers should emphasize that it is a permanent method, and make it clear that there is no extra benefit to doing the procedure at the time of the abortion versus using a non-permanent method for some time to be sure it is the method she wants. There may be laws and policies in place that affect a minor's ability to consent to permanent surgical modification and whether sterilization is an option for minors. Providers should offer information in a factual manner and support the young woman's informed decision.

### *Long-acting contraceptive methods*

Long-acting reversible contraception (LARC) such as intrauterine devices (IUDs) or implants are safe and effective and benefit young women. For all women, these methods are more effective at preventing pregnancy than other modern methods including pills, injections and condoms. In addition, because women who use IUDs or implants do not have to remember pills every day, buy more supplies or get an injection every three months there is no chance of method failure because of problems with use.

Young women have more difficulty using short acting methods than older women, resulting in pregnancy rates that are double that of older women who use short acting methods. Therefore the ease of use of IUDs and implants may be particularly beneficial for young women. Finally, women who use IUDs and implants are satisfied with them, leading to longer continuation than with pills or injectables. Because unintended pregnancy occurs when women stop or switch methods, satisfaction and continuation are keys to the effectiveness of IUDs and implants.

### *Intrauterine devices (IUDs)*

Young women are medically eligible to use IUDs. There are no clinical contraindications based on age alone. IUDs are less likely to be selected by young women than by older women in some countries. It is unclear whether this is in part due to providers' reluctance to offer IUDs to young women or young women's reluctance after being given accurate, unbiased information on the method.

However, a study in New Zealand found that women who did leave with an IUD in place were 70 percent less likely to return for an abortion in the next three years than those who left with combined oral contraceptive pills (Roberts 2010). Providers should give this information to clients but not push them to accept an IUD if the young woman is not interested in doing so.

### *Injectables*

Injectables include progestin-only and estrogen and progestin (“combined”) formulas, including DepoProvera (DMPA) and Mesigyna and Norigynon (NET-EN). In the same New Zealand study, DMPA was associated with a 40 percent decrease in likelihood of returning for abortion, compared to combined oral contraceptives pills (Roberts 2010).

There has been some concern that DMPA may permanently decrease bone mineral density (BMD) in young women, since it does temporarily decrease BMD and adolescents have not yet attained their peak bone mass. A study specifically on adolescent women found that all of them had complete recovery of BMD within 12 months of discontinuation, and length of use of DMPA did not affect this recovery (Scholes 2005). WHO’s latest recommendations on medical eligibility for contraceptives states that most studies have found that women regain BMD after discontinuing DMPA but that it is unclear whether use in young women will affect peak bone mass, and thus list it as a category 2 method (“generally use the method” – in comparison, category 1 means “use method in any circumstances”) for women under 18 (WHO 2010b).

### **Women with multiple abortions**

If a woman does not want to become pregnant and has experienced multiple unwanted pregnancies and abortions, the provider should help the woman identify any difficulties she may have using or accessing contraception and work with her to resolve those difficulties.

When discussing contraception with a woman who has had multiple abortions:

- Explore with the woman her history of contraceptive use. If she has not been using contraception, ask her about this, using non-judgmental language.
- If she has been using contraception, identify and resolve any difficulties she has experienced with her chosen method or help her select a method that may be more appropriate for her.
- If resupply of her chosen method has been problematic, help her identify a method that she can obtain more consistently.
- Advise the woman about how to access and use emergency contraception (EC) if she has unprotected intercourse or if contraceptive failure occurs. If possible, provide her with a supply of emergency contraceptive pills (ECPs).

### **Women who have experienced violence**

When helping a woman who has experienced violence, select an appropriate contraceptive method and ask her to consider whether there is a connection between the violence and her contraceptive use. If the violence is a result of her contraceptive use, help her consider a method that cannot be detected by others. If the woman cannot control the circumstances of her sexual activity, advise her on using methods that do not require partner participation such as injectables, intrauterine devices and implants and also how to access and use EC. It may be beneficial to provide ECPs in advance.

## Women living with HIV

The following information should be presented when discussing contraception with an HIV-positive woman:

- Male and female condoms help protect against HIV transmission and need to be used correctly each time intercourse occurs.
- If the woman engages in unprotected sexual intercourse with an infected partner, she may become infected with a different strain of HIV or other sexually transmitted infections (STIs).
- Dual protection is recommended. This practice consists of the simultaneous correct and consistent use of either male or female condoms for STI/HIV protection with another, more effective contraceptive method for pregnancy prevention, or with ECPs as a back-up method for pregnancy prevention. Women being treated for HIV need information on contraceptive options in relation to their treatment regimens.

## Commercial sex workers

The following information should be presented when discussing contraception with women who engage in sex work:

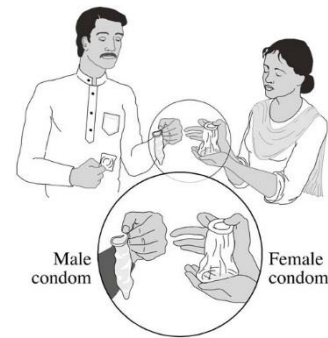

- Providers should recommend the use of dual protection, through the simultaneous use of condoms and another method, for protection against both STIs and unwanted pregnancy. If male condom use is not feasible for the woman, she may want to consider female condoms, if available
- Providers should advise against using an IUD or IUS, as the woman is at increased risk of having or contracting an STI.
- The woman should be informed on how to access and use ECPs. It may be beneficial to provide the woman with ECPs in advance.

## Women with cognitive and developmental disabilities and/or mental illness

The provider should begin by assessing what knowledge and experience the woman already has regarding contraception. The provider can then assist her in determining which method is most suitable for her by asking who she has sex with and under what circumstances.

The following information should be considered when discussing contraception with women who have cognitive disabilities and/or mental illness:

- The woman may have difficulty remembering how or when to use certain methods, such as taking a pill every day; however, these methods may still be a good option if instructions are given clearly and the woman has a caregiver who can help remind her and establish the method as part of her daily or monthly routine.
- Some women with developmental disabilities may have trouble with fine motor skills; in such cases, certain methods, such as diaphragms, may not be advisable.

- Women in this population should be instructed on how to use and negotiate barrier methods, and providers should emphasize that they must be used every time she engages in intercourse if she wants to prevent pregnancy and STIs.
- The provider should demonstrate the method—using actual condoms, diaphragms or cervical caps—and/or use illustrative instructions.
- Providers should also give the woman written and/or illustrative instructions to take home or other helpful tools such as a calendar.
- It is probable that many women in this population do not know in advance when they will engage in sexual intercourse. For this reason, the advance provision of EC pills, with specific instructions, may be advisable.
- Under no circumstances should any method be performed or provided without the woman’s explicit consent. Women with cognitive disabilities and/or mental illness have the same right as other women to make choices regarding childbearing.
- Regarding informed consent, providers should be aware that:
  - The woman may or may not be her own guardian.
  - If the woman is indeed able to make decisions about her own care, the provider should make an extra effort to ensure that she clearly understands what she is consenting to and what her choices are.

### **Women in refugee and displaced settings**

Such settings have complex needs and limitations, and are outside the scope of this curriculum.

### **Woman who have experienced genital mutilation**

A woman’s type of genital mutilation and her preferences around deinfibulation and reinfibulation need to be considered when supporting her in selecting her preferred contraceptive method. A recent review of the evidence shows no known increased incidence of HIV infection among women who have undergone female genital mutilation. As for all women, encourage the use of barrier methods, such as male and female condoms, to decrease the risk of HIV infection.

# Infection Prevention

## Key topics in this module:

- Common routes of infection transmission
- Essential elements of infection prevention, including standard precautions
- Management of occupational exposures

## 1.0 Introduction

Health-care facilities are prime settings for infection transmission because of the presence of numerous types of infectious agents.

- Health-care workers are exposed to infectious agents and contaminated materials as part of their daily work.
- Clients are exposed when they receive health-care services.
- Families and communities may be affected when clients and health-care workers unknowingly carry infections home from the health-care facility.

Most formally trained health-care workers are knowledgeable about infection-prevention techniques. It is the health-care worker's responsibility to take correct and consistent measures to guard against the spread of infection, using appropriate hygiene and infection-prevention techniques and behaviors.

This module addresses the application of infection-prevention principles in postabortion-care settings.

## 2.0 Infection transmission

Microorganisms are on and within the body, on medical instruments and equipment, and on every surface. Each microorganism has a specific route of transmission from one person to another. A pathogen is any microorganism that can cause infection and lead to disease. Each pathogen requires specific prevention measures, depending on how it is transmitted. This module focuses on preventing infections from bloodborne pathogens that are primarily transmitted through exposure to blood and other body fluids in a health-care setting.

Bacteria, viruses, protozoa, fungi and parasites are examples of pathogens that can be present in blood. Pathogens such as HIV (Human Immunodeficiency Virus), HBV (Hepatitis B Virus), HCV (Hepatitis C Virus) and Ebola can cause infection and disease in humans. All health care providers should be vaccinated against Hepatitis B.

Bloodborne pathogens are:

- Invisible to the naked eye;
- Transmitted through blood, secretions, excretions and certain other body fluids;
- Able to cause infection when infectious fluid enters the body through a cut, open sore or other opening in the skin or mucous membranes of the eyes, mouth or genitals;
- Able to cause disease in humans without noticeable signs or symptoms.

In a clinical setting, bloodborne pathogens can spread:

- From client to health-care worker;
- From health-care worker to client;
- From client to client;
- From health-care worker to health-care worker;
- From health-care worker or health facility to family and community members.

Health-care workers most often risk infection with bloodborne pathogens in two ways:

- 1) Punctures with contaminated sharp instruments, such as hypodermic needles;
- 2) Contact with blood on non-intact skin such as cuts or sores.

Transmission of bloodborne pathogens (especially HIV) from health-care workers to clients is extremely rare. Work assignments should not be based on workers' medical diagnoses, but on their skill and abilities.

## 3.0 Elements of infection prevention

Infection-prevention protocols are employed broadly to prevent infections regardless of their transmission routes. Health-care workers must use *standard precautions*, formerly called *universal precautions*, during contact with all clients and staff, as a person may carry infection without showing any noticeable signs or symptoms. Standard precautions are the

proper handling of blood and body fluids and the use of appropriate prevention techniques with all clients and staff at all times, regardless of their actual or perceived health status.

Using standard precautions minimizes the risk of pathogen transmission from contaminated sharp instruments that can penetrate the skin, and from infected blood or body fluids that can splash into the eyes or other mucous membranes or enter the body through a cut or broken skin.

Standard precautions involve infection-control measures that are designed to block transmission between the person and potentially infectious body fluids. These measures include proper hand washing techniques and wearing barriers such as gowns, gloves, aprons, masks, eyewear and footwear.

Standard precautions should be applied in all situations where health-care workers anticipate contact with:

- Blood
- Bodily fluids
- Secretions and excretions other than perspiration, regardless of whether they contain visible blood
- Non-intact skin
- Mucous membranes

Health-care workers should treat the blood and body fluids of all persons as potential sources of infection, independent of diagnosis or perceived risk. Standard precautions should be followed with all clients and all workers, regardless of their presumed infection status or diagnosis, and there is no reason to treat individuals with known bloodborne diseases differently.

All workers who risk exposure to blood or other body fluids should be vaccinated against HBV to reduce their risk of infection by that virus.

### 3.1 Handwashing

Hands are the most common vehicle for infection transmission. Handwashing is one of the most essential, yet most neglected, elements of infection prevention in health-care settings. Handwashing should be routine before and after each client contact, and after contact with potentially contaminated items, even if gloves are worn.

- Health-care workers should wash their hands by rubbing them together with clean, flowing water and soap.
- A brush may be used to clean hands thoroughly.

#### **Essential elements of infection prevention**

- *Handwashing*
- *Personal protective barriers*
- *Proper handling and disposal of sharp instruments and items*
- *Proper handling and processing of instruments and materials*
- *Aseptic technique*
- *Environmental cleanliness*
- *Proper disposal of infectious waste*



- It is essential to use fresh water because microorganisms can thrive in a container of water used by multiple people.
- When running water is not available by faucet, spigot or pump, one person can pour fresh water from a container, enabling another person to wash.
- Because shared and reused towels can transmit pathogens, it is ideal to use disposable towels or a clean towel each time handwashing occurs.
- Large towels can be cut into smaller towels or hands can be air-dried to conserve resources.

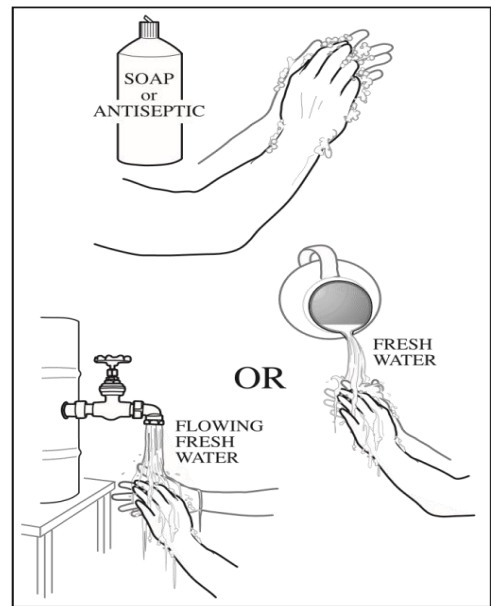

**Handwashing**

### 3.2 Use of personal protective barriers

Health-care workers must wear personal protective barriers such as gloves, gowns, aprons, footwear, eyewear, masks or shields to reduce their risk of infection by decreasing the likelihood of their exposure to microorganisms. Appropriate barriers must be worn whenever there is the possibility of contact with blood or other body fluids.

Using gloves properly:

- Always change gloves between client contacts; after contact with a potentially contaminated item; before touching sterile instruments; and between rectal and vaginal examinations.
- Wear gloves when drawing blood or starting an intravenous line.
- Remove gloves and wash hands immediately following a face shields procedure
- Wear gloves (ideally, utility gloves) while cleaning if there is the potential for hand contact with blood or other body fluids.

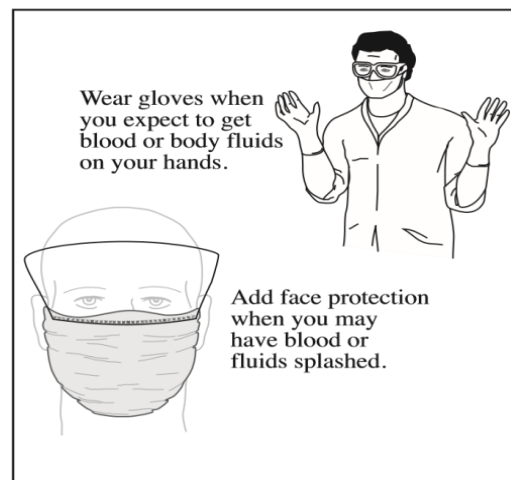
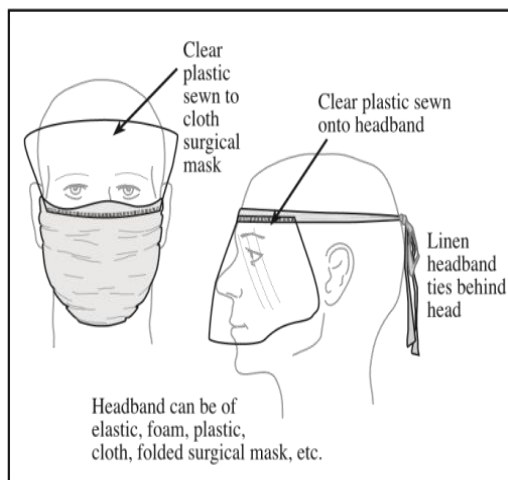

**Personal protective equipment**

### 3.3 Proper handling and disposal of sharp instruments and items

Sharp instruments or items, called sharps, include:

- Hypodermic and suture needles
- Scissors
- Tenacula
- Glass
- Blades

Sharps present a special risk of infection to health-care workers, clients and community members because they can puncture skin and introduce pathogens directly into the bloodstream. Such punctures occur most often when needles are recapped, cleaned, or disposed of inappropriately.

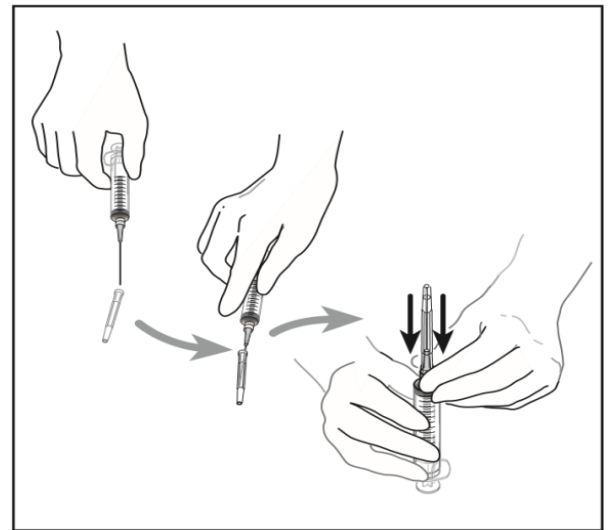

**Scoop and cap method**

Proper handling and disposal of sharps can significantly reduce this risk:

- Do not carry hypodermic needles.
- Set aside a specific area to keep sharp objects during procedures.
- Announce the presence and passage of any “sharps.”
- Dispose of needles and syringes immediately, in puncture resistant containers (without recapping, removing, cutting or bending them). Locate these containers wherever sharps are used. If syringes must be recapped for repeated use during a procedure, use the “scoop method.” (Please see Appendix A: Sharps Container for Box Assembly Instructions.)

### 3.4 Handling and processing instruments and materials

Microorganisms can live on instruments and materials used during uterine evacuation procedures. Health-care workers must remove microorganisms from contaminated instruments and materials to prevent them from infecting other women during subsequent procedures. The techniques for properly removing microorganisms from instruments are discussed in the Instrument Processing section of the Ipas MVA Instruments module.

### 3.5 Aseptic technique

The three critical components of aseptic technique for surgical procedures are:

- Antiseptic preparation
- No-touch technique
- Properly processed instruments

### *Antiseptic preparation*

During vacuum-aspiration procedures, post-procedure infection can be caused by the introduction of a woman's resident vaginal flora into her uterus. Therefore, it is critical to remove microorganisms normally present in the vagina and cervix prior to inserting an instrument.

- Ask the woman about any allergic reactions to antiseptics.
- Ensure that the perineal area is clean.
- Using the no-touch technique, the provider should use an antiseptic-soaked sponge to clean the cervical os and, if desired, the vaginal walls. With each new sponge, start at the os and spiral outward. Continue until the os has been completely covered by antiseptic.
- Do not clean the cervix with the same gauze used for cleaning the vagina.
- Povidine-iodine or chlorhexidine may be used for antiseptic solution.
- Saline may be used if antiseptics are not available.

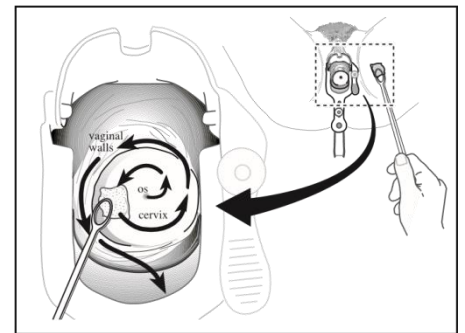

**Preparing the cervix**

### *No-touch technique*

It is possible to introduce pathogens, especially vaginal ones, into the uterus when passing an instrument into the uterine cavity. To avoid introducing pathogens, it is essential to use no-touch technique during surgical procedures and when handling sterile instruments, such as hypodermic needles and cannulae.

- Always handle instruments by the end that does not come into contact with the woman.
- No instrument that enters a woman's uterus should in contact with a contaminated surface before insertion through her cervix.
- The tenaculum, cannula or dilator tips should not touch the providers' gloves, the woman's vaginal walls, or unsterile parts of the instrument area.

### *Properly processed instruments*

All reusable medical instruments must be properly processed between clients. The techniques for properly processing instruments are discussed in the Instrument Processing section of this module: Ipas MVA Instruments.

## 3.6 Environmental cleanliness

Because health-care workers can spread infection when touching clinic surfaces and clients, it is important that everything in the clinical setting, including clients, instruments and equipment, be kept clean and dry.

- A chemical that kills microorganisms is called a *germicide*.

- *Antiseptics* are weaker germicides that are used for cleaning the body.
- Strong germicides used for cleaning equipment and processing instruments are called *disinfectants*. Ideally, a disinfectant of 0.5 percent chlorine solution can be used for cleaning rooms and equipment, although it is acceptable to use soap and water.

**Note:** Glutaraldehyde and chlorine are hazardous substances. Use personal protective equipment when mixing. Refer to the manufacturer’s safety instructions to establish safe use. (Please see Appendix B: Mixing instructions to produce 0.5% chlorine solution.)

At the beginning of each clinic session:

- Wipe all horizontal surfaces with a clean cloth, including procedure tables, chairs, trolley tops, lamps and counters.
- Mop floors with a clean mop to remove any dust.

Between clients:

- Clean blood or other body fluids with a 0.5% chlorine solution or other disinfectant.
- Clean any potentially contaminated surfaces, such as procedure tables and trolley tops, with a clean cloth dampened with a disinfectant cleaning solution.
- Clean visibly soiled areas of the floor, walls or ceiling with a disinfectant cleaning solution.
- Check sharps disposal containers and replace them if they are three-quarters full.
- Remove infectious waste.

At the end of each day:

- Check sharps disposal containers and replace them if they are three-quarters full.
- Remove infectious waste.
- Clean all surfaces with a clean cloth dampened with a disinfectant cleaning solution.
- Mop floors with a disinfectant cleaning solution.
- Wash waste containers with a disinfectant cleaning solution.

### 3.7 Disposal of infectious waste

Any disposable material that has come in contact with body fluids should be considered infectious waste and disposed of properly. Infectious waste can include:

- Human tissue, such as products of conception (POC)
- Body fluids
- Materials containing blood or body fluids, such as bandages, surgical sponges, hypodermic and suture needles, scalpel blades, blood tubes and pipettes
- Disposable medical instruments

Some local protocols dictate that a health facility’s infectious waste be removed by a second party, such as a private company or government organization, and disposed of off-site. Wherever infectious waste is deposited, it must always be contained and, ideally, incinerated.

All infectious waste must at least be secured and contained. It is unacceptable to store infectious waste in open containers or throw waste into an unsecured open pile, particularly near bodies of water; this exposes the community to infection. Contaminated sharp items should be placed in containers made from material that is not easily perforated, such as heavy cardboard or plastic.

To dispose of infectious waste, including POC:

Burning solid infectious waste in an incinerator or oil drum is the best option.

- Open burning in a secured area is an acceptable alternative.
- Bury solid infectious waste on-site, as long as it is secured behind a fence or wall away from any water source. Initial depth should be 2 to 5 meters deep. As waste is added, cover it with 10 to 30cm (four to 10 inches) of soil. When the level of waste reaches to within 30 to 50cm of the ground surface, fill the pit with dirt, seal it with concrete, and dig another pit. Burying waste is the next best option after burning.
- Pour liquid waste down a sink or drain connected to an adequately treated sewer pit or latrine. Burial of infectious liquid with other infectious waste is an acceptable alternative.

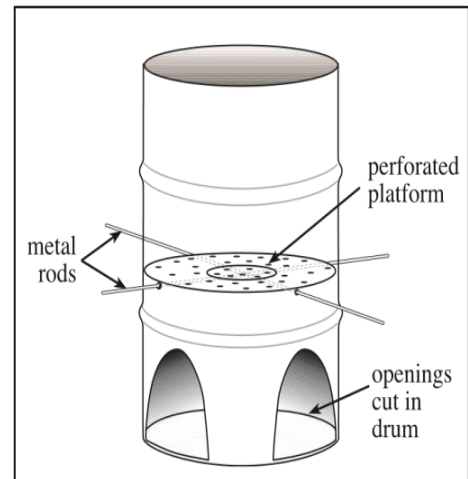

**Incinerator**

Products of conception (POC) resulting from uterine evacuation with misoprostol should be disposed of in the same way as other infectious waste. If a woman passes the POC at home, she should be advised to dispose of them by whatever appropriate means are available to her, such as pouring them down a toilet that is used for feces or by burying them away from a water source. If another person is going to dispose of the waste, he or she should use the precautions noted in this module for handling infectious waste.

#### **4.0 Management of occupational exposure**

In the event that a health-care worker is exposed to blood or other body fluids in any way—for example, by needle puncture or a splash to the face or skin—follow these procedures:

- If the exposure caused a bleeding wound, briefly allow the wound to bleed.
- Immediately flush the exposed area with clean water. Wash wounds and skin thoroughly with soap and water. Flush the mucous membranes (nose, eyes, mouth) with water or saline only. If water is not available, use an antiseptic solution.

- Determine the type of fluid and type of exposure.
- Evaluate the exposure source by testing a known source or by evaluating the risk posed by an unknown source.
- Evaluate the exposed person's immune status, including his or her history of HBV vaccination.
- Give post-exposure prophylaxis for exposures posing a risk of infection.
- Offer voluntary, confidential HIV, HBV and HCV counseling and testing, if available.
- Consult an infectious-disease specialist, if possible.
- Record the exposure and actions taken according to facility protocols. Discuss how another exposure could be prevented in the future and share lessons learned with all staff.
- During follow-up care, advise the exposed person to seek medical evaluation for any acute illness that develops.

### Chlorine bleach in Pakistan

*Several brands of chlorine bleach are available. However, the strength of the solution is not provided on most chlorine bleach in Pakistan. Strengths of some of the most common brands are as follows:*

Robin Bleach	5 %
CHLOR TABS	8680mg troclosesene sodium, per tablet (Green Star Marketing)
Effervescent HAZ TAB chlorine releasing tablets for disinfection	1.8g troclosesene sodium, per tablet; 1 g chlorine available per tablet (www.guest-medical.co.uk, available through Unicon)
Unicon Bleach	32% solution

## 5.0 Summary

- Health-care facilities are prime settings for infection transmission to health-care workers, clients and community members because of the presence of numerous types of infectious agents.
- Standard precautions should be applied in all situations where health-care workers anticipate contact with blood, secretions, excretions and other body fluids, non-intact skin, and mucous membranes.
- Hands are the most common vehicle for infection transmission.
- The essential elements of infection prevention are handwashing, use of personal protective barriers, proper handling and disposal of sharp instruments and items, proper handling and processing of instruments and materials, use of aseptic technique, environmental cleanliness and proper disposal of infectious waste.
- The three critical components of aseptic technique for vacuum aspiration are antiseptic preparation, no-touch technique and properly processed instruments.
- All infectious waste should be incinerated or, at the very least, secured and contained properly.
- If a health-care worker is exposed to blood or other body fluids, follow appropriate procedures for the management of occupational exposures.

## References

- Association of Operating Room Nurses. (2010). *Aseptic technique* [Video]. Denver, CO: Association of Operating Room Nurses.
- Association of Operating Room Nurses. (2012). *Perioperative standards and practices for inpatient and ambulatory settings*. Denver, CO: Association of Operating Room Nurses.
- EngenderHealth. (2000). *Infection prevention: A reference booklet for healthcare providers, 2nd edition*. Retrieved from <http://www.engenderhealth.org/pubs/quality/infection-prevention.php>
- Grudemann, B. J., & Mangum, S. S. (2001). *Infection prevention in surgical settings*. Philadelphia, PA: W. B. Saunders Company.
- Siegel, J. D., Rhinehart, E., Jackson, M., & Chiarello, L. (2007). *Guideline for isolation precautions: Preventing transmission of infectious agents in healthcare settings*. Retrieved from <http://www.cdc.gov/hicpac/2007IP/2007isolationPrecautions.html>
- Tietjen, L., Bossemeyer, D., & MacIntosh, N. (2003). *Infection prevention: Guidelines for healthcare facilities with limited resources*. Baltimore, MD: JHPIEGO.
- World Health Organization. (2007). *Managing complications in pregnancy and childbirth: A guide for midwives and doctors*. Integrated management of pregnancy and childbirth (IMPAC) (Second ed.). Geneva: World Health Organization.
- World Health Organization. (2012). *Safe abortion: Technical and policy guidance for health systems*. Geneva: World Health Organization.

## Appendix A: Sharps Container

Instructions for making a sharps container:

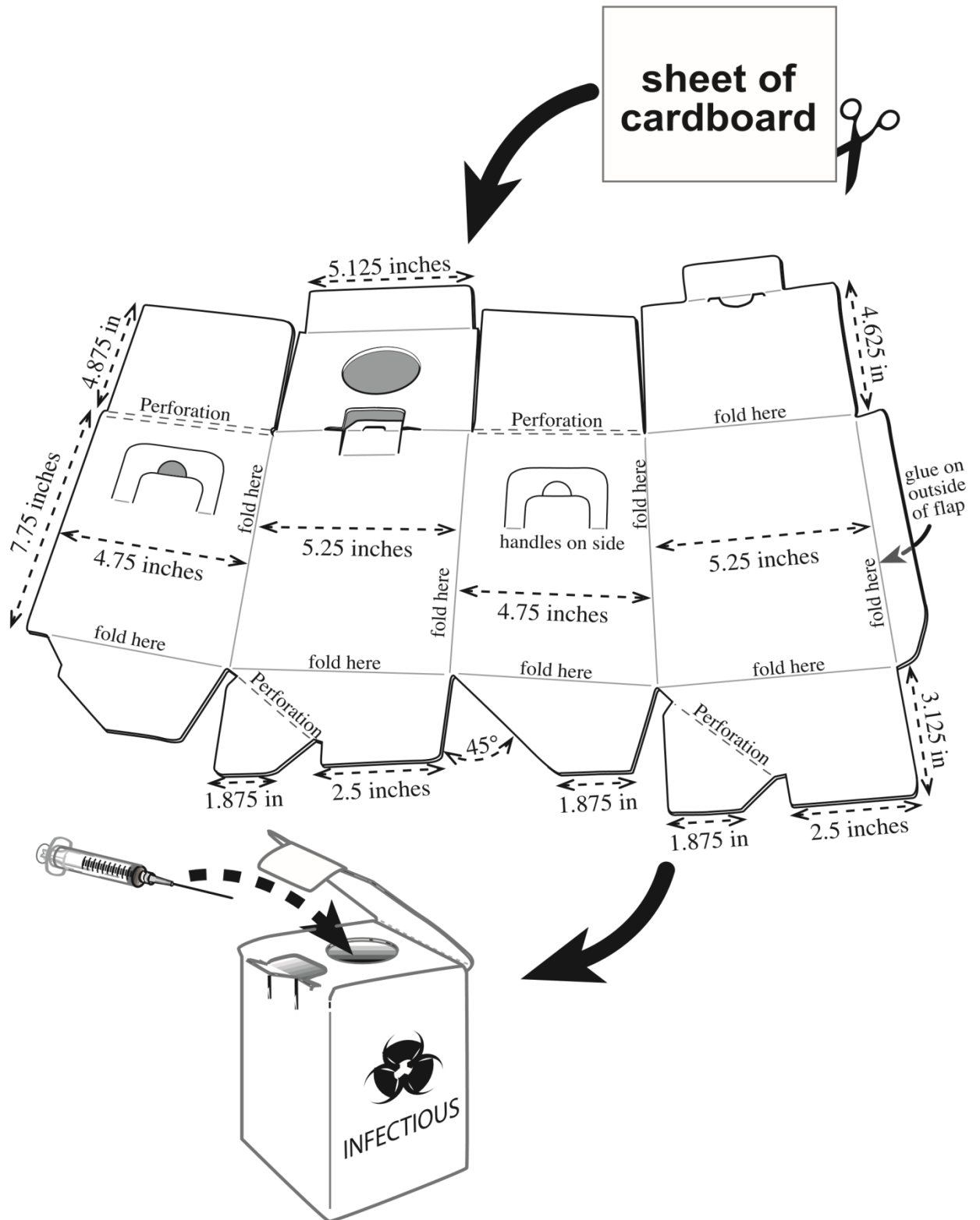



**Appendix B: Mixing instructions to produce 0.5% chlorine solution**

(Mix according to the strength of the locally available brand of bleach)

Chlorine Compound	Available Chlorine in Compound	† To Produce 0.5% Solution
Sodium Hypochlorite Solution (Bleach)*	3.5% (Africa, JIK; Nepal, Robin; Jamaica, Ajax) 5% (France & Vietnam, Eau de Javel; Canada & USA, Clorox, household bleach; Peru, Clorox) 6% (Mexico, Blanqueador) 10% (UK, Chloros; Peru, Liguria) 15% (France, Extrait de Javel; UK, Chloros)	Mix 10mL bleach with 60mL water (1 part bleach to 6 parts water) Mix 10mL bleach with 90mL water (1 part bleach to 9 parts water) Mix 10mL bleach with 110mL water (1 part bleach to 11 parts water) Mix 10mL bleach with 190mL water (1 part bleach to 19 parts water) Mix 10mL bleach with 290mL water (1 part bleach to 29 parts water)
Calcium Hypochlorite	70%	Dissolve 7 grams calcium hypochlorite in 1L water
NaDCC (Sodium Dichloroisocyanurate)	60%	Dissolve 8.5g NaDCC in 1L water
NaDCC-Based Tablets (Sodium Dichloroisocyanurate)	1.5g per tablet	Dissolve 4 tablets in 1L water
Chloramine (Tosylchloramide sodium)	25%	Dissolve 20g in 1L boiled water

*(Adapted from Tietjen 2003.)*

† A 0.5% solution is recommended since clean (boiled or filtered) water is often not available for making the solution and much of the chlorine may be inactivated by microscopic organic matter in the water. Where boiled or filtered water is available, a 0.1% solution is satisfactory.

\* Glutaraldehyde and chlorine are hazardous substances. If processing instruments or for environmental use, take necessary precautions such as using personal protective equipment. Refer to the manufacturer's safety instructions to establish safe use.

# Clinical Assessment

## Key topics in this module:

- Complete clinical assessment
- Conditions such as ectopic pregnancy and reproductive-tract infections
- Special client considerations

## 1.0 Introduction

Women who are pregnant and present with vaginal bleeding and/or lower abdominal pain or cramping may have a threatened abortion, a spontaneous, missed or incomplete abortion, complications from a safe, self-induced or unsafe abortion, or complications resulting from previous postabortion care. To give them care, clinical assessment should focus on the health status of the woman and whether she has suffered any abortion-related complications. Women who present for postabortion care need to have a rapid initial assessment for shock. Some women who present for postabortion care will be unstable with serious complications that need immediate attention including severe bleeding or hemorrhage, infection or sepsis and intra-abdominal injury. Management of women with a more unstable or severe presentation will be discussed in the Complications module. Treatment may require immediate uterine evacuation. Once a woman has been stabilized, the clinical assessment should focus on the type of abortion (incomplete or

missed), whether there are complications that need attention and her eligibility for methods of uterine evacuation.

In general, women who present for postabortion care are stable with light to moderate vaginal bleeding and no other complications. These women need a full clinical assessment and, depending on the results, a uterine evacuation procedure. Clinical assessment for women who need postabortion care and are stable without complications is covered in this unit.

It is essential to assess a woman's clinical status and eligibility for medical methods, vacuum aspiration or expectant management. This allows the provider to assist the woman in making an informed choice about her preferred method of uterine evacuation.

The assessment should be conducted in private. The components of a complete clinical assessment are:

- Client history
- Physical exam
- Collection of specimens and ordering of any lab tests, only if needed

An important part of the clinical assessment is an evaluation of the woman's emotional state, relevant relationship and family circumstances, and support systems, as they have a direct bearing on her clinical experience. Open, supportive communication and a gentle, reassuring manner help ensure that the provider obtains the relevant information needed to offer the best possible care for the woman. (Please see the Informed Consent, Information and Counseling module.)

## 2.0 Client history

A client history is important to determine the woman's gestational age and eligibility for available methods, and to provide information that will help the provider meet her other reproductive and sexual health needs. The provider needs to ask the woman about and record her medical history, including:

- First day of last menstrual period (LMP);
- Signs and symptoms of pregnancy;
- Whether she had a pregnancy test or ultrasound and what the results were;
- Whether she has had any bleeding or spotting during the pregnancy;
- Whether she has had any pelvic pain or cramping. If yes, determine:
  - Whether it is intermittent (like contractions) or constant
  - The severity on a scale of 1 to 10, 10 = "worst pain I've ever felt";
- Known drug allergies;
- Medications including misoprostol or herbal remedies;

- Obstetric and gynecological history, such as number of previous pregnancies, live births, miscarriages or abortions, history of contraceptive use, history of ectopic pregnancy, menstrual history, fibroids, infections or any recent abortion-related care;
- Hepatitis B and C, HIV status and presence of other sexually transmitted infection (STI);
- Surgical history;
- Physical or cognitive disability, including mental illness;
- Known health conditions (for example see Table 9-1).

(Please see Appendix B: Sample client record form for an example.)

### **Last menstrual period**

*The LMP refers to the first day of a woman's last menstrual period. A woman may need help remembering this date. Questions about where she was, what she was doing and what was happening in her life may help her recall when her last period began.*

*LMP estimations may be difficult for other reasons, including:*

- *Women presenting for postabortion care may experience bleeding during early pregnancy, which can be mistaken for a menstrual period.*
- *A young woman may experience irregular menstrual cycles or may never have experienced a menstrual period before she becomes pregnant.*
- *Breastfeeding women may become pregnant without having regular menstrual periods.*
- *Certain methods of contraception may make menstrual cycles irregular or infrequent.*

*Use of LMP to estimate gestational age may be more accurate for women who rely heavily on fertility awareness methods. However, a woman's LMP should not be the only factor in determining the gestational age of a pregnancy. Because women presenting for postabortion care may need treatment for a pregnancy that has been partially expelled or for a pregnancy that has stopped developing, the uterine size on clinical exam is more important to determine appropriate care.*

### *Prior self-administration of misoprostol*

Providers may see women who self-administered misoprostol to terminate a pregnancy prior to seeking care in the health system. Providers should be aware of the clinical implications that may accompany prior misoprostol use. If women used the recommended regimens, the success rate for misoprostol only is 85 percent. For the 15 percent of unsuccessful abortions, women may present with an ongoing pregnancy or may require vacuum aspiration to empty the uterus. Even if a woman has already used misoprostol before presenting in the facility, she may be offered misoprostol for uterine evacuation if she is medically eligible. Some women may present with significant bleeding that needs urgent treatment. Women with an ongoing pregnancy should be counseled about the very rare risk of birth defects if they choose to continue the pregnancy.

Table 9-1: Health conditions

<p><b>If a woman has any of the following health conditions, uterine evacuation provision may require a higher degree of clinical judgment, skill and monitoring. A uterine evacuation procedure may need to be modified to suit the health needs of the woman. Referral to a higher-level facility may also be appropriate.</b></p>	
Health Condition	Comments
Hypertension	<ul style="list-style-type: none"> <li>Methylergometrine should not be used in women with hypertension</li> </ul>
Seizure disorder	<ul style="list-style-type: none"> <li>The woman should take her usual dose of anti-seizure medication on the day of the uterine evacuation procedure and resume her medication as soon as possible. She may receive sedation with benzodiazepines and other pain control measures before performing the procedure.</li> <li>Because some anti-epileptic drugs interact with hormonal contraception, contraceptive options should be carefully reviewed for medical eligibility.</li> </ul>
Anemia	<ul style="list-style-type: none"> <li>If hemoglobin is very low, be prepared to manage bleeding and treat appropriately.</li> </ul>
Blood-clotting disorders	<ul style="list-style-type: none"> <li>If the woman has an active clotting disorder, proceed with caution.</li> <li>Treatment in a higher-level facility may be appropriate.</li> </ul>
Diabetes	<ul style="list-style-type: none"> <li>No changes in diet or medications are recommended for vacuum aspiration with local anesthesia.</li> <li>High blood glucose levels are preferable to low blood glucose levels at the time of vacuum aspiration.</li> </ul>
Heart disease	<ul style="list-style-type: none"> <li>If symptomatic or severe disease, vacuum aspiration may be performed in an operating room and monitored with the assistance of an anesthetist.</li> </ul>
Asthma	<ul style="list-style-type: none"> <li>Women with mild or well controlled asthma may have a routine vacuum aspiration or uterine evacuation with misoprostol.</li> <li>Women with an acute asthma attack or poorly controlled asthma may need to have delayed care until asthma is under control.</li> <li>Misoprostol is safe for use in women with asthma.</li> </ul>
Suspected ectopic pregnancy	<ul style="list-style-type: none"> <li>Evaluate and treat or refer according to local protocol.</li> <li>Ectopic pregnancy is a life-threatening emergency that requires treatment.</li> </ul>
Cervical stenosis	<ul style="list-style-type: none"> <li>Consider performing vacuum aspiration under ultrasound guidance, using an agent such as misoprostol or laminaria to prepare the cervix prior to procedure.</li> <li>Medical methods may be offered.</li> </ul>
Alcohol or drug abuse	<ul style="list-style-type: none"> <li>Women may require larger doses of medication for pain control and sedation due to tolerance.</li> </ul>

- If misoprostol has been used to terminate a pregnancy 13 weeks or greater, providers should be alert to the potential for heavy bleeding, which may be stopped by vacuum aspiration.
- Cervical dilatation may not be needed in vacuum aspiration when misoprostol has been used to initiate an abortion because misoprostol softens the cervix.

(Please see the Uterine Evacuation with Misoprostol module.)

### 3.0 Physical examination

Clinicians who provide postabortion care should have strong skills in pelvic examination and be competent in dating and sizing a pregnancy. Three commonly used approaches to pregnancy dating are:

- Determining the date of LMP
- Performing a pelvic exam to assess uterine size
- Using ultrasound

Although understanding the gestational age is important, the uterine size is critical in postabortion care as it determines eligibility.

#### 3.1 General health

The physical exam should begin with a general health assessment, which includes:

- Checking and recording the woman's vital signs, such as temperature, pulse, and blood pressure
- Noting signs of general health, including weakness, lethargy, anemia or malnourishment
- Checking the woman's abdomen for masses and tenderness

Women who have suffered complications of an unsafe abortion may need urgent care.

(Please see the Complications module.)

#### 3.2 Pelvic examination

The pelvic examination includes a speculum and bimanual exam, which may be conducted consecutively or in either order. Prior to performing a pelvic exam, the clinician should ask the woman to empty her bladder and let her know what to expect. This is especially important if this is the woman's first pelvic exam, which is most likely in young or nulliparous women.

#### Verbal reassurance

*Explain to the woman what to expect and what she might feel before beginning the pelvic exam. Ask her if she would like to have a support person with her. If this is her first pelvic exam, she may be anxious, and it is particularly important to reassure her. (For more examples of verbal reassurance, please see the Uterine Evacuation Procedure with Ipas MVA Plus® module.)*

### Positioning the woman

- Help the woman move into the lithotomy position.
- Use drapes or linens to make sure her privacy is protected.
- Attend to any special anatomical or physical needs, including disability, arthritis or injuries.
- Attend to any IV lines or other critical items.
- Ensure that she feels as comfortable as possible.



**Lithotomy position**

### Speculum exam

The speculum exam can be performed during the clinical assessment or during preparation for the uterine evacuation procedure. Before inserting the speculum, inspect the external genitalia and perineum. Note whether there are ulcers or signs of STIs on the external genitalia.

- Warm the speculum if possible; this can be done under the exam light.
- Gently insert a speculum of the appropriate size and inspect the cervix and vaginal canal carefully.
- Check for bleeding. If present, check the amount and source of the bleeding.
- Check for an open cervical os or products of conception in the os or vagina. If products are noted, they may be removed gently with ring forceps.
- Note if the blood or any discharge has an odor. Infection is sometimes indicated by a foul odor.
- Note any pus or discharge from the cervical os. Active cervical infection present at the time of a uterine evacuation procedure increases the chance of postabortal infection.
  - If infection is present or suspected, take samples for culture, if possible.
  - Women with signs and symptoms of a reproductive tract infection should be treated immediately and the procedure can be performed without delay. (Please see Appendix A: Provision of Antibiotics.)
- Note any cervical lesions; visual inspection of the cervix can help identify cervical dysplasia.
- Check for prior self-administration of misoprostol or signs of unsafely induced abortion.

#### **Dorsal position**

Where leg supports are not available, the dorsal or “frogleg” position can be used. In this position, the woman’s pelvis should be raised by placing a stack of blankets or linens under her lower back or upper buttocks.

### *Bimanual exam*

- The provider should perform a bimanual exam to assess the size, consistency and position of the uterus and adnexa.
- Signs of pregnancy, including softening of the cervix and softening and enlargement of the uterus, are detectable during the bimanual exam as early as six to eight weeks since the LMP.
- Women with signs of a pelvic infection will have cervical, uterine or lower abdominal tenderness on bimanual exam.
- After six weeks gestation, the uterus increases in size by approximately 1 centimeter per week and takes on a roundish shape.
- To assess the uterus and adnexa, the provider places two fingers into the vagina and then palpates the abdomen with the other hand. The size of the uterus is then compared with the history of amenorrhea.
- The technique of assessing uterine size is the same in all women, including young women.

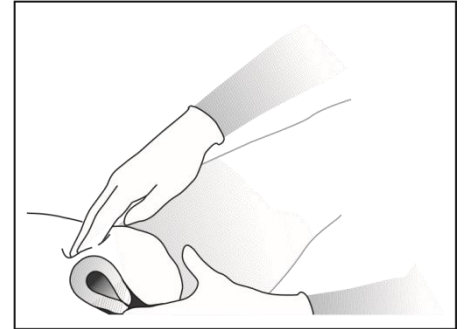

**Bimanual exam**

If the uterus is **smaller** than expected, providers should consider one of the following conditions:

- The woman is not pregnant
- Inaccurate menstrual dating
- Spontaneous or incomplete abortion, missed abortion or abnormal intrauterine pregnancy, such as molar pregnancy
- Normal variation between women at a given length of pregnancy
- Ectopic pregnancy

If the uterus is **larger** than expected, providers should consider one of the following conditions:

- Inaccurate menstrual dating
- Multiple pregnancies
- Uterine anomalies such as fibroids or bicornuate uterus
- Molar pregnancy (although the uterus can sometimes be smaller also)
- Normal variation between women at a given length of pregnancy



Situations that make it difficult to accurately assess uterine size include fibroids, retroverted position of the uterus, obesity, full bladder or the woman contracting (not relaxing) her abdominal muscles. If a clinician is uncertain about the uterine size, it may be helpful to ask another provider to perform a bimanual exam or, if readily available, use ultrasound.

### 3.3. Determining the type of abortion

During the history and physical exam, providers should be evaluating whether a woman has a threatened, missed, incomplete or complete abortion because the management of each of these conditions differs. (Please see Appendix C: Diagnosis and treatment of types of abortion.) When a woman presents with an incomplete abortion, whether the abortion was spontaneous or the result of a prior safe or unsafe abortion does not affect the management, although women with a history of unsafe abortion are more likely to suffer complications that need treatment.

## 4.0 Laboratory tests

In most cases, providers only need the information obtained from a woman's history and physical examination and do not need laboratory testing or ultrasound. According to the World Health Organization (WHO), "obtaining such tests should not hinder or delay uterine evacuation."

- Hemoglobin or hematocrit tests to detect anemia may be helpful in areas where anemia is prevalent in order to treat women and help providers manage bleeding during uterine evacuation.
- The need for routine Rhesus (Rh) immunization for Rh negative women undergoing postabortion care has not been proven by clinical studies and if Rh testing is not possible, then abortion services should **not** be withheld. If Rhesus immunization is not given it should be documented. Where Rh immunoglobulin is available and routinely provided to Rh-negative women, this protocol should also be applied for women having postabortion care. It should be administered at the time of the procedure when performing vacuum aspiration or with misoprostol.
- The postabortion care visit is an opportunity to screen for other reproductive health issues including cervical dysplasia and cancer and reproductive tract infections. These services may be offered to women if they are available but are not required to provide care.

### Use of Anti-D Immunoglobulin for Rhesus D Prophylaxis

- *Anti-D Ig (500 IU) is not required for spontaneous miscarriage before 12+0 weeks of gestation, provided there is no instrumentation of the uterus.*
- *Anti-D Ig should be given to non-sensitized Rh D-negative women undergoing surgical evacuation of the uterus, regardless of gestation.*
- *Anti-D Ig should be considered for non-sensitized Rh D-negative women undergoing medical evacuation of the uterus, regardless of gestation*
- *Anti-D Ig should be given to all non-sensitized Rh D -negative women who have spontaneous complete or incomplete miscarriage at or after 12+0 weeks of gestation*

*Source: RCOG Greentop Guideline No.22, March 2011*

## 5.0 Ultrasound exam and ectopic pregnancy

### *Ultrasound*

Ultrasound is not required for postabortion care. Ultrasound can be used when there is difficulty assessing gestational age or uterine size based on history and exam, to assess uterine evacuation completion and to diagnose other conditions requiring treatment, such as ectopic pregnancy. Routine ultrasound may increase the cost of the procedure and the likelihood of unnecessary intervention.

### *Ectopic pregnancy*

While rare, ectopic pregnancy may be suspected in women during clinical assessment due to her history, risk factors, symptoms or testing. A woman's risk of ectopic pregnancy is 10-15% if she has had a previous ectopic pregnancy. Conception after a tubal ligation is rare, but the risk for ectopic pregnancy is 25-50% if she becomes pregnant after having had tubal surgery. On the rare occasions that an IUD fails and pregnancy occurs, 6-8% are ectopic pregnancies.

In the presence of any of these three risk factors, a high degree of suspicion is needed. Referral to a higher level facility for diagnosis and treatment of ectopic pregnancy may be needed. The symptoms of ectopic pregnancy are nonspecific and may be associated with threatened or spontaneous abortion or normally developing intrauterine pregnancy. (Please see the Complications module.) Even with careful screening, only half of women presenting to an emergency room with ectopic pregnancy have risk factors or a suspicious physical exam. Ultrasound and serial BHCG testing can aid in the diagnosis of un-ruptured ectopic pregnancy, but access to these tests may be limited in many facilities.

## 6.0 Reproductive tract infections

Administering prophylactic antibiotics to all women at the time of vacuum aspiration helps reduce their risk of infection. If prophylactic antibiotics are not available, however, vacuum aspiration should still be performed. For women with signs and symptoms of infection, therapeutic antibiotics to treat the infection should be given immediately and the procedure can still be performed. If women presenting for abortion care are routinely screened for reproductive tract infections, they do not have to wait for laboratory results

### **Syndromic Management of Sexually Transmitted Infections (STIs)**

*Syndromic management is based on the identification of consistent groups of symptoms and easily recognized signs (syndromes), and the provision of treatment that will deal with the majority or most serious organisms responsible for producing a syndrome.*

*WHO developed a simplified tool (a flowchart or algorithm) to guide health workers in the implementation of syndromic management.*

*Source: WHO [Guidelines for the Management of Sexually Transmitted Infections \(2001\)](http://apps.who.int/medicinedocs/en/d/Jh2942e/2.4.html)*

*WHO [Guidelines for the Management of Sexually Transmitted Infections \(2003\)](http://apps.who.int/iris/bitstream/10665/42782/1/9241546263_enq.pdf?ua=1)*

before having a procedure. For recommended doses, see Appendix A: Provision of antibiotics.

For uterine evacuation with misoprostol, prophylactic antibiotics are not recommended. For women with signs and symptoms of infection, therapeutic antibiotics to treat the infection should be given immediately. (Please see the Uterine Evacuation with Misoprostol module.)

#### **HIV prevalence in Pakistan**

- *Around 106,000 HIV positive people live in Pakistan.*
- *Around 50 percent of the affected are in Sindh and almost 80% of the province's total number live in Karachi*
- *In 2014, out of 994 new HIV/Aids cases detected in Sindh - 905 were men, 8 were women and 6 were children (4 boys and 2 girls — aged less than seven years). These children were either cases of mother-to-child HIV transmission or were thalassemic.\**

Source: \*Sindh Aids Control Programme (SACP), as reported to <http://www.dawn.com/news/1147347> in November, 2014.

#### **HIV Treatment & Care Centers in Pakistan**

*The Enhanced HIV & AIDS Control Program (Federal Component) and Provincial AIDS Control Programs have established 18 HIV Treatment and Care Centers nationwide. These centers provide comprehensive HIV care services including free antiretroviral therapy, free advanced HIV diagnostics such as CD4 and HIV Viral load testing, management of HIV related opportunistic infections and counseling services to HIV positive people of Pakistan.*

Source: For further details of the Prevention or Treatments Centers, please visit <http://www.nacp.gov.pk>

## **7.0 Special considerations during clinical assessment**

### *Young women*

Young women may have never had a clinical or pelvic exam and may be apprehensive or afraid. Providers should be particularly empathetic, sensitive and helpful when physically examining young women. Before the examination, explain what will be done and why and do not begin the examination without obtaining consent, even if an adult has legally consented on her behalf (WHO 2010a). When the pelvic examination begins, ask permission before touching her with a hand or speculum. Explain what you are doing at each step of the examination.

### *Female genital mutilation*

Women who have undergone female genital mutilation (FGM) may need specialized care.

### *Violence*

Providers should be supportive and reassure the woman. Women who have experienced violence may be afraid or feel uncomfortable about being touched. There are often no

physical signs of violence against women. However, providers should be alert to the following signs, while understanding that these signs can also be present outside the context of violence:

- New or old bruises on the woman’s body, including the genital area, head, neck or upper arm;
- Injuries that do not fully match the explanation of how they occurred;
- Burns or marks with distinctive patterns, such as cigarette burns;
- STIs, pelvic inflammatory disease, urinary-tract infection, chronic irritable bowel syndrome, chronic pelvic pain;
- Vaginal bleeding, painful defecation or painful urination and abdominal or pelvic pain.

These signs may indicate the need for further discussion and screening for violence by providers to determine if a woman is in a dangerous situation. If this proves to be the case, providers should do what they can to help the woman before she leaves their care. Referrals to existing resources should be made before she leaves the facility, as many women may not return for follow-up appointments. (Please see Appendix A: Special Considerations in the Informed Consent, Information and Counseling module.)

## 8.0 Summary

- Providers should do a rapid initial assessment for shock or other severe complications that need urgent treatment.
- Most women presenting for postabortion care are clinically stable with light to moderate bleeding. Clinical assessment can assist in the diagnosis of the type of abortion and determine the management plan.
- During the clinical assessment, the provider should meet with the woman in private to discuss her information and perform an examination.
- Clinical assessment for postabortion care should include taking a client history, conducting a physical exam, and, if needed, collection of specimens and ordering of any lab tests.
- Client history helps determine the woman’s gestational age and uterine size, her eligibility for vacuum aspiration, misoprostol or expectant management, and provides information to help the provider meet her other reproductive and sexual health needs.
- The physical examination involves assessing the women’s general health and performing a pelvic exam.
- Laboratory testing and ultrasound are not required for routine postabortion care services but may be helpful if a woman’s pregnancy status and dating are unclear.
- Where possible, prophylactic antibiotics should be administered prior to vacuum aspiration to help reduce women’s risk of post-procedure infections. Prophylactic antibiotics are not needed for misoprostol for uterine evacuation. Lack of access to antibiotics should not be a barrier to postabortion care.

## References

- Achilles, S. L., & Reeves, M. F. (2011). Prevention of infection after induced abortion: release date October 2010: SFP guideline 20102. *Contraception*, 83(4), 295-309.
- American College of Obstetricians and Gynecologists Task Force on Female Genital Cutting. (2007). *Female genital cutting: Clinical management of circumcised women*. Washington, DC: American College of Obstetricians and Gynecologists.
- Barnhart, K. T. (2009). Ectopic Pregnancy. *The New England Journal of Medicine*, 361(4), 379-387.
- Blanchard, K., Cooper, D., Dickson, K., Cullingworth, L., Mavimbela, N., von Mollendorf, C., Winikoff, B. (2007). A comparison of women's, providers' and ultrasound assessments of pregnancy duration among termination of pregnancy clients in South Africa. *BJOG*, 114(5), 569-575.
- Castleman, L., Winikoff, B., & Blumenthal, P. (2009). Providing abortion in low resource settings. In M. e. Paul, E. S. e. Lichtenberg, L. e. Borgatta, D.A. e. Grimes, P. G. e. Stubblefield & M. D. e. Creinin (Eds.), *Management of unintended and abnormal pregnancy: Comprehensive abortion care. Second edition*. (pp. 319-334). West Sussex, UK: Wiley-Blackwell.
- Davis, A., & Easterling, T. (2009). Medical Evaluation and Management. In M. Paul, S. E. Lichtenberg, L. Borgatta, D. A. Grimes, P. G. Stubblefield & M.
- D. Creinin (Eds.), *Management of Unintended Pregnancy and Abnormal Pregnancy: Comprehensive Abortion Care*. West Sussex, UK: Wiley Blackwell.
- De Bruyn, M. (2003). *Violence, pregnancy and abortion: Issues of women's rights and public health*, second edition. Chapel Hill, NC: Ipas.
- Fielding, S. L., Schaff, E. A., & Nam, N.-Y. (2002). Clinicians' perception of sonogram indication for mifepristone abortion up to 63 days. *Contraception*, 66(1), 27-31.
- Heise, L., Ellsberg, M., & Gottemoeller, M. (1999). Ending violence against women. *Population Report, Series L*(11), 1-43.
- Løkeland, M., Iversen, O. E., Dahle, G. S., Nappen, M. H., Ertzeid, L., & Bjørge, L. (2010). Medical abortion at 63 to 90 days of gestation. *Obstetrics and Gynecology*, 115(5), 962-968.
- May, W., Gülmezoglu, A. M., & Ba-Thike, K. (2007). Antibiotics for incomplete abortion. *Cochrane Database of Systematic Reviews, Issue 4*.
- Stovall, T. G., Kellerman, A. L., Ling, F. W., & Buster, J. E. (1990). Emergency department diagnosis of ectopic pregnancy. *Annals of Emergency Medicine*, 19(10), 1098-1103.
- World Health Organization. (1994). *Clinical management of abortion complications: a practical guide*. Geneva, Switzerland: World Health Organization.
- World Health Organization. (2007). *Managing complications in pregnancy and childbirth: A guide for midwives and doctors Integrated management of pregnancy and childbirth (IMPAC) (Second ed.)*. Geneva: World Health Organization.
- World Health Organization. (2012). *Safe abortion: Technical and policy guidance for health systems*. Geneva: World Health Organization.
- World Health Organization (WHO). (2009). *Medical eligibility criteria for contraceptive use* (pp. 1 online resource (121 p.)). Retrieved from [http://whqlibdoc.who.int/publications/2010/9789241563888\\_eng.pdf](http://whqlibdoc.who.int/publications/2010/9789241563888_eng.pdf)
- World Health Organization (WHO). (2010a). *Adolescent job aid: A handy desk reference tool for primary level health workers*. Geneva, Switzerland: World Health Organization. Retrieved from [http://whqlibdoc.who.int/publications/2010/9789241599962\\_eng.pdf?ua=1](http://whqlibdoc.who.int/publications/2010/9789241599962_eng.pdf?ua=1)
- World Health Organization Department of Reproductive Health and Research (WHO/RHR) and Johns Hopkins Bloomberg School of Public Health/Center for Communication Programs (CCP), Knowledge for Health Project. (2011 update). *Family Planning: A Global Handbook for Providers* Baltimore and Geneva: CCP and WHO. Retrieved from [http://whqlibdoc.who.int/publications/2011/9780978856373\\_eng.pdf?ua=1](http://whqlibdoc.who.int/publications/2011/9780978856373_eng.pdf?ua=1)

World Health Organization (WHO).(2013). Female Genital Mutilation Information Fact Sheet. 241. Retrieved from <http://www.who.int/mediacentre/factsheets/fs241/en/>

Yao, M., & Tulandi, T. (1997).Current status of surgical and nonsurgical management of ectopic pregnancy.*Fertility and Sterility*, 67(3), 421-433.

## **Appendix A: Provision of antibiotics**

### **Prophylactic antibiotics**

#### *Vacuum aspiration*

Routine prophylactic antibiotics are recommended for treatment of incomplete or missed abortion with vacuum aspiration. Women with signs or symptoms of infection should be given therapeutic antibiotics. Scant literature exists supporting routine antibiotics during vacuum aspiration for incomplete or missed abortion. However, routine prophylactic antibiotics are recommended before vacuum aspiration for induced abortion, and therefore in the absence of evidence, it seems prudent to administer prophylactic antibiotics for vacuum aspiration when used for postabortion care.

The ideal medication, dose and timing for prophylactic antibiotics before vacuum aspiration has not been established but a single dose of nitroimidazoles, tetracyclines or penicillins have all been shown to be effective. Commonly used regimens include:

- Doxycycline 200-500mg orally prior to the procedure
- Metronidazole 400mg orally every 4 hours x 3 doses

#### *Misoprostol*

Prophylactic antibiotics prior to uterine evacuation with misoprostol are not recommended. Therapeutic antibiotics should be given to women with signs and symptoms of infection.

### **Therapeutic antibiotics**

Therapeutic antibiotics should be administered to all women who are suspected of or who have been diagnosed with an infection. If possible, women at high risk should be screened and treated for sexually transmitted infections in addition to receiving prophylactic antibiotics. Women who are screened for sexually transmitted infections do not need to wait for results before having uterine evacuation. If the testing is positive, they may be treated after the uterine evacuation. Women who have signs and symptoms of active infection when they present for postabortion care should be treated for the infection and provided uterine evacuation services without delay.

## Appendix B: Sample client record

Client's Name \_\_\_\_\_ Date \_\_\_\_\_ Age \_\_\_\_\_

Abortion

Indication \_\_\_\_\_

Obstetrical history: G \_\_\_\_\_ P \_\_\_\_\_

# of vaginal deliveries \_\_\_\_\_ # of cesarean sections \_\_\_\_\_ Previous ectopic pregnancy? \_\_\_Yes\_\_\_No

Any previous complications?

\_\_\_\_\_

### Medical History:

Body System	Check if yes	Diagnosis
Respiratory (e.g. asthma)		
Cardiovascular (e.g. hypertension)		
Gastrointestinal		
Endocrine and Metabolic (e.g. diabetes)		
Genitourinary (other than pregnancies or sterilization)		
Neurologic (e.g. seizure disorder)		
Psychiatric		
Hematologic (e.g. bleeding disorders and/or anemia)		
Allergies		
Surgeries (other than cesarean)		

### Physical Exam:

BP \_\_\_\_\_ Pulse \_\_\_\_\_ Temp \_\_\_\_\_

Heart:	Bimanual Exam:
Lungs:	Other:
Abdomen:	



## Appendix B: Sample client record (continued)

### Dating:

First day of last menstrual period \_\_\_\_\_

Uterine size by bimanual exam \_\_\_\_\_

\*\*\*\*Today's Estimated Gestational Age \_\_\_\_\_\*\*\*\*

### Optional Testing:

These tests are not required to offer postabortion care but may be performed as indicated:

Hb/Hct \_\_\_\_\_ Blood type \_\_\_\_\_

Rh-immunoglobulin given (if indicated) \_\_Yes \_\_No

Pregnancy test and date \_\_\_\_\_

HIV testing offered \_\_Yes \_\_No Accepted? \_\_Yes \_\_No

Other reproductive health testing? (e.g., pap smear) \_\_\_\_\_

Ultrasound Date \_\_\_\_\_ Gestational Age \_\_\_\_\_

Today's gestational age by ultrasound \_\_\_\_\_

Planned Contraception \_\_\_\_\_

### For Medical Methods:

Regimen prescribed: \_\_\_\_\_

Instructions for administration given: \_\_Yes \_\_No

Pain management plan: \_\_\_\_\_

Follow-up visit (if necessary): Date \_\_\_\_\_ Time \_\_\_\_\_

### For Vacuum Aspiration:

Antibiotics given: \_\_Yes Type \_\_\_\_\_

Pain management plan: \_\_\_\_\_

Follow-up visit (if necessary) Date \_\_\_\_\_ Time \_\_\_\_\_

## Appendix C: Diagnosis and treatment of types of abortion

Probable Diagnosis and Definition	Signs and Symptoms	Management Options
<p><b>Threatened abortion</b> – vaginal bleeding in woman with a viable intrauterine pregnancy</p>	<ul style="list-style-type: none"> <li>• Light bleeding</li> <li>• Cramping/pain</li> <li>• Closed cervix</li> <li>• Uterine size corresponds to LMP</li> </ul>	<ul style="list-style-type: none"> <li>• Reassurance</li> <li>• Expectant management</li> <li>• If continued bleeding, further clinical assessment</li> </ul>
<p><b>Incomplete abortion</b> – an abortion—whether spontaneous or induced—in which some pregnancy tissue passes out of the uterus but some remains</p>	<ul style="list-style-type: none"> <li>• Light to heavy bleeding</li> <li>• Cramping/pain</li> <li>• Open cervix</li> <li>• May see tissue at the cervical os</li> <li>• Uterine size corresponds to or is smaller than LMP</li> </ul>	<ul style="list-style-type: none"> <li>• Depending on the clinical condition and the woman’s preference, she may be offered expectant management, misoprostol or vacuum aspiration</li> <li>• Antibiotics if indicated</li> <li>• Pain control</li> </ul>
<p><b>Missed abortion</b> – a kind of miscarriage; the pregnancy ends, but the tissue remains in the uterus</p>	<ul style="list-style-type: none"> <li>• Light to no bleeding</li> <li>• Cramping/pain</li> <li>• Closed cervix</li> <li>• Uterine size smaller than LMP</li> <li>• Diagnosis may be made on ultrasound</li> </ul>	<ul style="list-style-type: none"> <li>• Depending on the clinical condition and the woman’s preference, she may be offered expectant management, misoprostol or vacuum aspiration</li> </ul>
<p><b>Complete abortion</b> – all products of conception have been expelled from the uterus and the os is closed</p>	<ul style="list-style-type: none"> <li>• Light bleeding</li> <li>• Cramping/pain</li> <li>• Closed cervix</li> <li>• Uterine size smaller than LMP</li> </ul>	<ul style="list-style-type: none"> <li>• Expectant management</li> <li>• Antibiotics if indicated</li> <li>• Pain control</li> </ul>

# Ipas MVA Instruments

## Key topics in this module:

- Instrument features and use
- Processing and care of instruments

## 1.0 Introduction

The objective of this module is to explain the features of the Ipas MVA Plus aspirator® and Ipas EasyGrip cannulae® used for uterine evacuation, as well as provide information about the care and use of these instruments. The module will also explain how to process and store the instruments.

## 2.0 Instrument features and use

Ipas MVA Plus and Ipas EasyGrip cannulae are safe, effective instruments designed to meet women's uterine evacuation needs.

Other models of Ipas instruments are similar. (Please Appendix A: Comparison of Ipas instruments.)

### 2.1 Description of Ipas MVA instruments

MVA instruments consist of a manual vacuum source (aspirator) that produces suction and holds tissue and blood removed in uterine evacuation procedures. Cannulae are attached to the aspirator and used to apply suction to aspirate tissue from the uterus.

### Aspirators

The Ipas MVA Plus aspirator provides a vacuum of 24 to 26 inches (609.6 to 660.4mm) of mercury. It is composed of a hinged valve with a cap, a removable liner, a pair of buttons that control the vacuum, a plunger with a handle, a collar stop with a retaining clip, an O-ring and a 60cc cylinder for holding evacuated uterine contents. The Ipas MVA Plus is compatible with Ipas EasyGrip cannulae, flexible Karman cannulae, and cannulae from other major manufacturers.

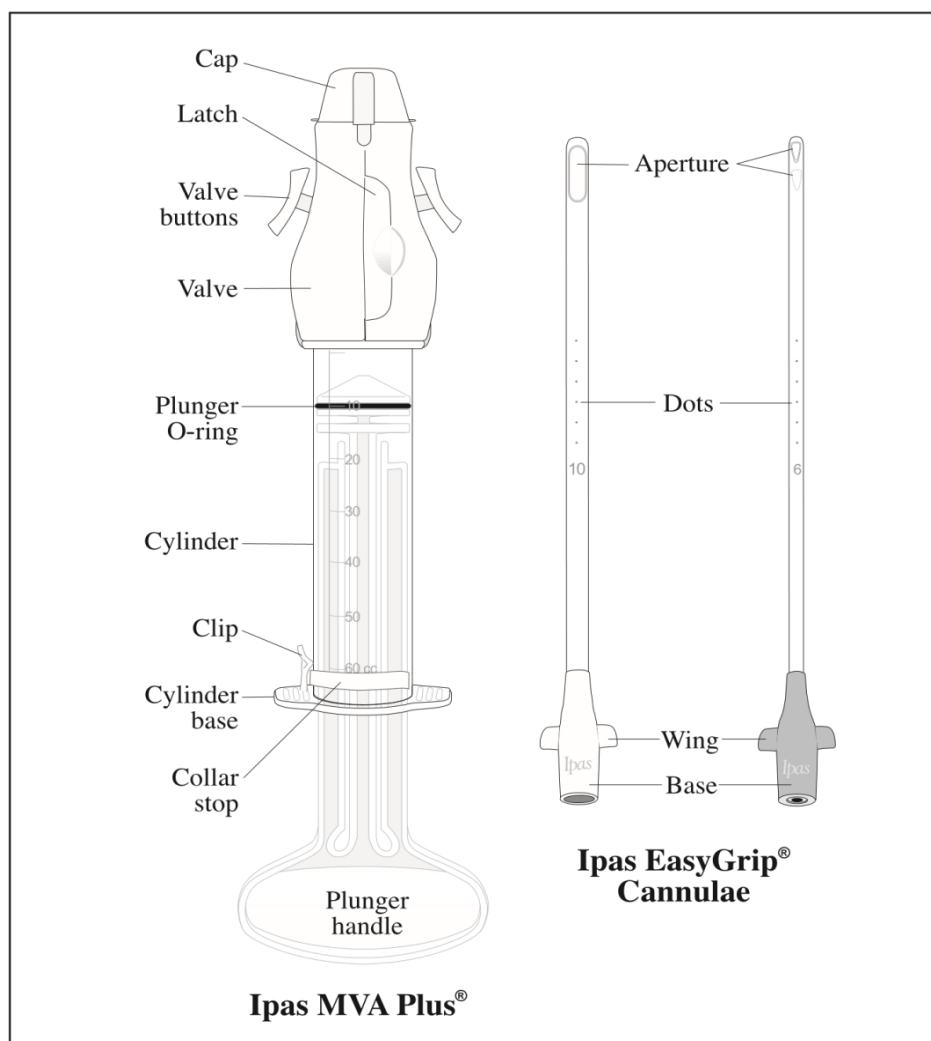

**Instrument parts assembled**

Ipas MVA Plus aspirators are designed for multiple use – they can be re-used. Aspirators are clean when shipped and must be high-level disinfected or sterilized prior to first use and after each procedure to remove contaminants. Aspirators do not need to remain high-level disinfected or sterile until next use like cannulae (see below). They can be stored in a clean place until next use.

The Ipas MVA Plus aspirator is made of steam-autoclavable materials and was designed specifically to allow steam contact with all surfaces when disassembled. It can also be processed with cold sterilization or high-level disinfection.

### *Cannulae*

Ipas EasyGrip cannulae are compatible with the Ipas MVA Plus aspirator and the Ipas double-valve aspirator, but they do not fit the Ipas single-valve aspirator. Ipas EasyGrip cannulae, depending on size, have either one aperture (9, 10 and 12mm sizes) or two apertures (4, 5, 6, 7 and 8mm sizes).

The winged shape of the base of the cannulae provides leverage, making it easy to attach a cannula to the aspirator and remove it quickly. No adapters are needed with Ipas EasyGrip cannulae. There are six dots on each cannula, with the first located 6cm from the end and the other dots at 1cm intervals. The dots indicate the location of the main aperture.

Ipas EasyGrip cannulae are considered “semi-rigid” cannulae. This means that the cannulae are less pliable than the flexible Karman cannulae. Some providers have reported that the smallest Ipas EasyGrip cannulae feel a bit firmer than the flexible Karman cannulae and are easier to insert through the cervix, while other providers have reported no notable difference in the feel and flexibility of the cannulae.

- Each new cannula is sterilized with ethylene oxide and remains sterile in its package until the stated expiration date, as long as the package is intact. Cannulae must be sterile or high-level disinfected (HLD) after use.
- Ipas EasyGrip cannulae are reusable after processing where regulations allow. These cannulae require high-level disinfection or sterilization between patients and must remain HLD or sterile until it is inserted into the uterus.
- The flexible Karman cannulae are single-use devices. After use, treat and dispose as infectious waste.
- Ipas EasyGrip cannulae are made of steam-autoclavable materials. All Ipas cannulae can also be processed with cold sterilization or high-level disinfection.
- Always follow proper protocols on the processing of medical instruments and on the disposal of infectious waste when processing and discarding MVA instruments.

## 2.2 Uses of Ipas MVA Plus aspirator and Ipas EasyGrip cannulae

All Ipas aspirators and cannulae up to 12mm are intended for uterine evacuation in obstetrics and gynecology clients. Clinical indications for uterine aspiration with this product are: treatment of incomplete abortion, for uterine sizes up to 12 weeks since the last menstrual period (LMP), first-trimester abortion (also called menstrual regulation in some countries) and endometrial biopsy.

### **The MVA Aspirator**

*The aspirator does not directly touch the woman’s body. However, when it is used, the cylinder fills with blood.*

*There is the potential risk that some contaminants from a previous woman could be introduced to another woman if the MVA aspirator is not fully processed (soaked, cleaned and sterilized or HLD) between each use. Therefore, after cleaning, the Ipas MVA Plus aspirator must undergo high-level disinfection or sterilization between patients to remove contaminants. Once processed, the aspirator may be kept in a clean container until next use.*

*(The aspirator does not need to remain HLD or sterile until next use like the cannula.)*

## 2.3 Contraindications, warnings and precautions

Endometrial biopsy should not be performed in cases of suspected pregnancy. There are no known contraindications for other clinical indications. History of blood dyscrasia may be a factor in the woman's care.

As with any uterine evacuation procedure, one or more of the following may occur during or after an MVA procedure: vagal reaction, incomplete evacuation, uterine or cervical injury or perforation, pelvic infection or acute hematometra. Rarely, some of these conditions can lead to secondary infertility, serious injury or death. (Please see the Complications module.)

Any life-threatening conditions that are present when a woman seeks care should be addressed immediately. These include: shock, hemorrhage, cervical or pelvic infection, sepsis, perforation or abdominal injury, as may occur with incomplete abortion or with clandestine abortion. Uterine evacuation is an important component of the management of these cases and once the woman is stabilized, the procedure should not be delayed.

The provider should not perform uterine evacuation until the size and position of the uterus and cervix have been determined. Large fibroids or uterine anomalies may make it difficult to determine the size of the uterus and hard to perform intrauterine procedures, including MVA. (Please see the Clinical Assessment module.)

It is important to use a cannula size appropriate to the size of the uterus and amount of cervical dilation present. Using a cannula that is too small may result in retained tissue or loss of suction. Following are the ranges of suggested cannula sizes relative to uterine size for uterine evacuation with MVA:

- Uterine size 4–6 weeks by clinical assessment: 4–7mm cannula
- Uterine size 7–9 weeks by clinical assessment: 5–10mm cannula
- Uterine size 9–12 weeks by clinical assessment: 8–12mm cannula

## 2.4 Functioning of the Ipas MVA Plus aspirator

Appropriate client preparation, counseling and informed consent should be performed before any uterine evacuation procedure. To perform the procedure, a cannula is inserted through the cervical os and then attached to an aspirator in which a vacuum has been prepared. The vacuum is then started by releasing the valve buttons and the cannula is used to aspirate the uterus as required. Suction can be started and stopped as needed during the procedure.

Specific guidance on performing uterine-aspiration procedures is included later in this module.

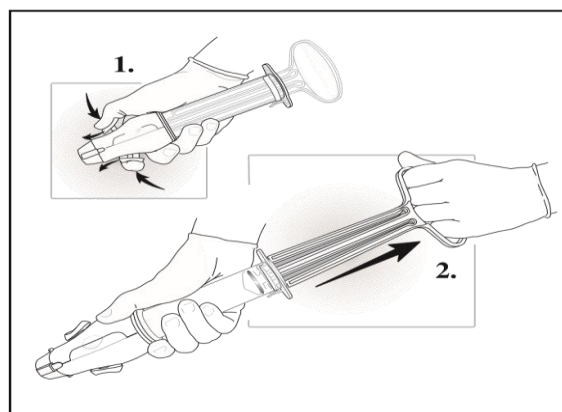

**Vacuum being created with MVA Plus**

### **Ipas 3mm cannulae for endometrial biopsy**

*The Ipas 3mm cannula intended use and clinical indication is endometrial biopsy in gynecology patients. Applications for endometrial biopsy may include cases of:*

- *Infertility*
- *Abnormal uterine bleeding*
- *Amenorrhea*
- *Screening for endometrial infections*
- *Screening for endometrial cancer*

*Ipas 3mm cannulae have two apertures and a winged base. Each cannula is sterilized with ethylene oxide (ETO) after packaging and remains sterile until the stated expiration date, as long as the package is intact. Cannulae must be sterile or high-level disinfected (HLD) when used. An adapter is required for use with the Ipas double-valve aspirator and the Ipas MVA Plus aspirator. No adapters are required for use with the Ipas single-valve aspirator.*

*Ipas 3mm cannulae are single use devices. After use, treat soiled cannulae as infectious waste.*

#### *Preparing a vacuum and checking vacuum retention*

With the Ipas MVA Plus, a vacuum should be prepared in the aspirator and the vacuum checked before beginning the procedure. To prepare a vacuum in the aspirator, follow the steps below:

1. Begin with the valve buttons open (not pressed), the plunger positioned all the way into the cylinder and the collar stop locked in place, with the tabs pushed down into the holes in the cylinder.
2. Push the buttons down and forward until they lock into place.
3. Create a vacuum by pulling the plunger back until the arms of the plunger snap outward and catch on the wide sides of the cylinder base. Both plunger arms must be fully extended to the sides and secured over the edges of the cylinder. Incorrect positioning of the arms can allow them to slip back inside the cylinder. The vacuum-charged aspirator should **never** be grasped by the plunger arms. If the charged aspirator is grasped by both arms, it may inadvertently release the plunger back into the cylinder. Releasing the plunger into the cylinder during a procedure could push the aspirator contents back into the uterus.
4. Check the aspirator for vacuum retention before each use. To do this, follow steps 1, 2, and 3 and then let the aspirator sit for a few moments after establishing the vacuum. Then push the buttons to release the vacuum. A rush of air into the aspirator should be heard, indicating that a vacuum was retained.
5. If the rush of air is not heard, displace the collar stop, withdraw the plunger and check the following:
  - a. Is the plunger O-ring intact, rather than nicked or damaged, free of foreign bodies and positioned in the groove?
  - b. Is the cylinder firmly placed in the valve?
  - c. Has the plunger O-ring been properly lubricated, over-lubricated, or not lubricated at all?

- Then create a vacuum and test it again. If the vacuum is still not retained, discard and use another aspirator.

### Stopping and starting suction

To start suction, release the valve buttons on the vacuum-charged aspirator. To stop suction, push the buttons to close the valve. During use, suction is started after the cannula is in place in the uterus. It may be stopped and started during the procedure, if needed.

### 3.0 Processing and care of Ipas instruments

With the worldwide increase of infectious agents such as the human immunodeficiency virus (HIV), hepatitis B (HBV) and other infectious microorganisms that can be transmitted in a clinical setting, health workers must be vigilant about protecting their clients, themselves, their families and their communities. Many of these microorganisms live in blood, other body fluids and excretions and on body surfaces, and they can continue to live on every item that they come in contact with, including instruments used for MVA procedures. Microorganisms that can live on medical instruments include endospores and bacteria, which have a hard outer coating and are difficult to destroy. (Please see the Infection Prevention module.)

Refer to the chart below to determine a protocol for processing.

The four basic steps for processing contaminated Ipas MVA Plus aspirators and Ipas EasyGrip cannulae are:

- Decontamination soak
- Cleaning
- Sterilization or high-level disinfection
- Storage

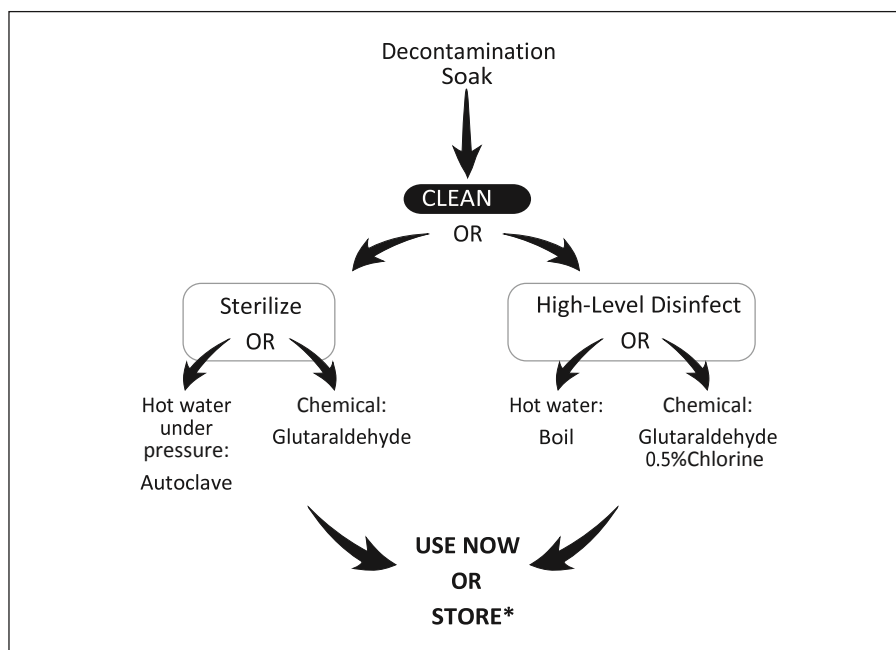

Processing options for Ipas instruments

\* Once sterilized or HLD, **aspirators** do not need to remain sterile or high-level disinfected for the next use and can be stored in a clean place until the next use. **The ability to store the cannula depends on the processing method (see storage section below).**



Table 10-1 shows common processing methods for Ipas instruments. Using inappropriate methods may damage the instruments and render them unusable.

Table 10-1: Summary of Common Processing Methods for Ipas Instruments

Instrument	Status when supplied by Ipas	Minimum level of processing required for use	High-level disinfection		Sterilization	
			Chlorine <sup>†</sup>	Boiling	Steam	Glutaraldehyde <sup>†</sup>
<p>All Ipas instruments that are reused should be kept wet until cleaning. A disinfectant such as a 0.5% chlorine solution can be used.</p> <p><b>CAUTION:</b> Letting the instruments dry may make it difficult to completely remove all contaminants. To clean aspirators, wash all surfaces thoroughly in warm water and detergent. Detergent is preferable to soap, which can leave a residue.</p>						
Ipas MVA Plus aspirator	Clean	HLD	Yes	Yes	Yes	Yes
Ipas Single- Valve aspirator	Clean	HLD	Yes	<b>No</b>	<b>No</b>	Yes
Adapters	Clean	HLD	Yes	Yes	Yes	Yes
Ipas EasyGrip cannula	Sterile (ETO)	HLD	Yes	Yes	Yes	Yes
Ipas Double-Valve* aspirator	Sterile (ETO)	Single use only				
Flexible Karman cannula	Sterile (ETO)	Single use only				
Ipas3mm cannula	Sterile (ETO)	Single use only				
<p>† Liquid processing agents are hazardous substances. When processing instruments, take necessary precautions, such as using personal protective equipment. Refer to the manufacturer's safety instructions to establish safe use.</p> <p>* Ipas Double-Valve aspirator is ONLY available in the United States and the United Kingdom at the time of this publication</p>						

(Please see Appendix B: Methods for processing Ipas MVA Plus aspirators and adapters and Ipas EasyGrip cannulae.)

### 3.1 Standard precautions

It is important to follow standard precautions for infection prevention when processing instruments. Even following a decontamination soak, instruments will retain harmful microorganisms.

- Always wear gloves when handling blood or other body fluids.
- Use personal protective barriers, such as gowns or face protection, when a given part of the body may be exposed to blood or other body fluids.
- Consider all blood and other body fluids from every person to be infectious.
- Guard against skin punctures from sharp instruments.
- Wash hands immediately before and after contact with contaminated items, even if gloves were worn.

(Please see the Infection Prevention module.)

*Note:* Glutaraldehyde and chlorine are hazardous substances. If processing instruments, or for environmental use, take necessary precautions such as using personal protective equipment. Refer to the manufacturer's safety instructions to establish safe use.

### 3.2 Decontamination soak

Following the procedure, all instruments to be reused should be kept wet until they can be cleaned. A 0.5% chlorine solution can be used. Soaking instruments immediately after use removes some infectious material and makes them easier to clean by preventing material from drying on them. For easy accessibility, the container used for the decontamination soak should be kept close to the procedure area—for example, on the bottom shelf of the instrument trolley. Soaking in a disinfectant, however, does not make items safe to handle with bare hands. It is essential to wear personal protective gear when handling instruments.

#### *Steps*

1. Fill a plastic container with solution. A 0.5% chlorine solution can be used.
2. Wearing gloves, submerge the cannula and aspirator completely. Make sure to flush the solution into the aspirator and cannula.
3. Soak instruments until ready to clean.
4. Use gloves or forceps when removing instruments from the solution.

If the cannula will not be reused, dispose of it and other infectious waste appropriately. Do not let the instruments dry before cleaning as this may make it difficult to completely remove all contaminants.

### 3.3 Cleaning

The second step in instrument processing is cleaning. Thorough physical cleaning is essential before sterilization or HLD to remove organic and inorganic material on the instruments that can interfere with the effectiveness of these processes. This is the most important step to ensure proper final decontamination of instruments.

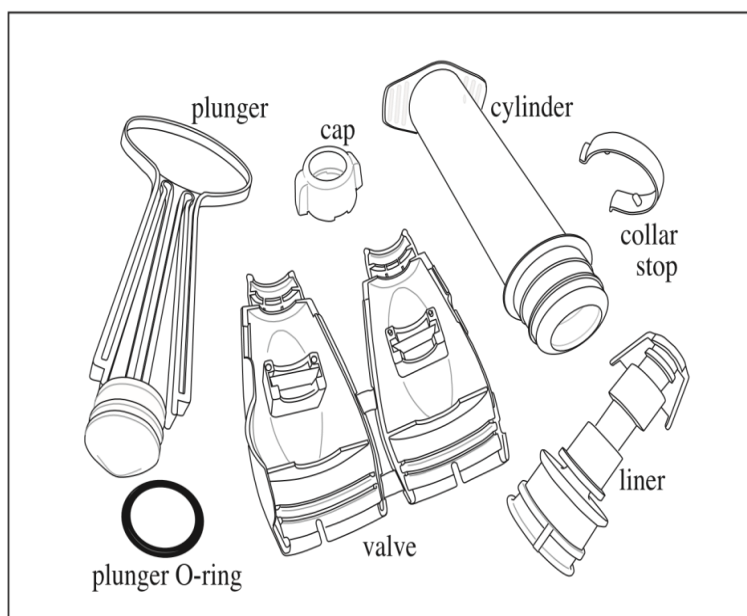

**MVA parts disassembled**

#### *Disassembly of Ipas instruments*

Ipas aspirators must be disassembled for processing, and they must be correctly assembled after processing in order to function properly. To disassemble the Ipas MVA Plus aspirator:

1. Pull the cylinder out of the valve.
2. Press down the cap-release tabs to remove the cap. Then open the hinged valve by pulling open the clasp and remove the valve liner.
3. Disengage the collar stop by sliding it sideways under the retaining clip or removing it completely from the cylinder.
4. Pull the plunger completely out of the cylinder.
5. Displace the O-ring from the plunger by squeezing the sides of the O-ring and rolling it down into the groove below. It is not necessary to completely remove it.

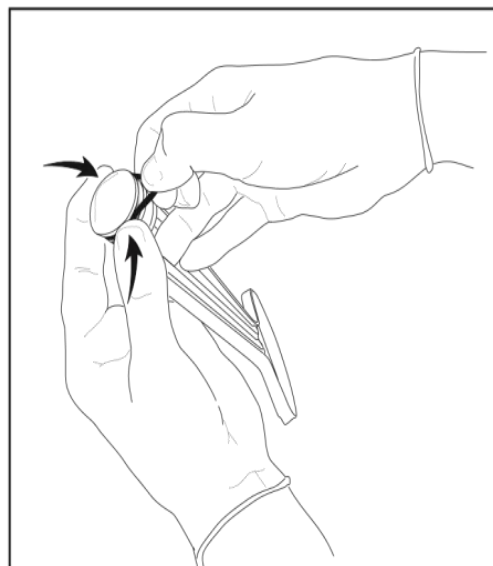

**Remove the O-ring**

### Steps in cleaning

Disassemble instruments before cleaning.

1. Remove remaining tissue or blood by washing all surfaces thoroughly in warm water and detergent or soap. Detergent is preferable, as soap may leave a sticky residue. If tissue or dried blood is trapped inside the cannula, flush water through the cannula repeatedly or use a cotton-tipped probe or soft cloth to remove material.
2. Clean the crevices and interior of the cylinder, valve parts and plunger using a soft-bristle brush, being careful not to splash.
3. Clean each item until no tissue or blood is visible upon careful inspection, then rinse.



**Clean thoroughly**

Allow items to dry. **Caution:** Do not use any pointed or sharp objects to clean the valve or to move the O-ring. This could damage the valve liner or the O-ring and prevent the device from maintaining vacuum.

### 3.4 Sterilization and high-level disinfection

Sterilization or high-level disinfection (HLD) of instruments further inactivates microorganisms. Sterilization effectively eliminates all microorganisms, including endospores. High-level disinfection eliminates all microorganisms except endospores.

For any sterilization or high-level disinfection process to be effective, physical cleaning to remove all visible traces of soil is required.

**After cleaning, both aspirators and cannulae must undergo sterilization or high-level disinfection between patients to remove contaminants. Devices are then safe to use for the next procedure. Aspirators do not need to *remain* sterile or high-level disinfected until next use. Aspirators can be kept in a clean place until next use. Cannulae must remain sterile or high-level disinfected until next use.**

For optimal infection prevention, items should be processed using a method that provides the highest level of effectiveness. When best practices are followed, the following methods are listed in order of effectiveness:

- Sterilization using steam autoclave
- Sterilization using cold methods (e.g., glutaraldehyde)
- HLD methods (e.g., boiling, chlorine, other cold methods)

High-level disinfection or sterilization according to one of the options below is required to reuse Ipas aspirators or cannulae. Additional methods which are less universally available for sterilization and high-level disinfection are included in Appendix B: Methods for Processing Ipas MVA Plus Aspirators and adaptors and Ipas EasyGrip Cannulae.

- Steam autoclave instruments at 121°C (250°F) with a pressure of 106kPa (15 lbs/in<sup>2</sup>) for 30 minutes.

*Note:* Ipas double-valve and single-valve aspirators and flexible Karman cannulae will crack or melt if autoclaved.

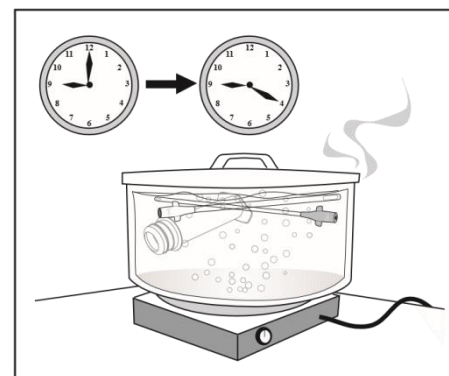

**Boiling MVA instruments**

- Sterilize using glutaraldehyde. Soak the clean instruments in glutaraldehyde (Cidex or a similar product) for 10 hours. Follow the manufacturer's recommendations for the product used. All Ipas aspirators can withstand glutaraldehyde processing.
- High-level disinfect by boiling. Place the clean instruments in water at a rolling boil for 20 minutes.
- *Note:* The Ipas MVA Plus aspirator, Ipas EasyGrip cannulae and flexible Karman cannulae can be boiled; however, Ipas double-valve and single-valve aspirators can crack or melt if boiled.
- High-level disinfect using glutaraldehyde. Soak the clean instruments in glutaraldehyde (Cidex or a similar product) for 20 minutes. Follow manufacturer's recommendations for the product used.
- High-level disinfect using a 0.5% chlorine solution. Soak the clean instruments in a 0.5% chlorine solution for 20 minutes.

#### *Steps to sterilize using steam autoclave*

1. All parts of the Ipas MVA Plus aspirator and Ipas EasyGrip cannulae can be steam sterilized at 121°C (250°F). Parts should not touch each other and the collar stop should be completely removed from the cylinder. Arrange the instruments without obstructing apertures or the opening at the base end of the cannulae to allow drainage.
2. Since the cannulae, particularly the smaller sizes, may curve in a steam autoclave, package them in paper or linen. Place the clean Ipas EasyGrip cannulae and the Ipas MVA Plus aspirator in a single layer in a steam autoclave. Note that steam sterilizing unwrapped Ipas EasyGrip cannulae for 30 minutes may result in slight curvature.
3. Process instruments in the steam autoclave for 30 minutes at 121°C (250°F).
4. Cool all instruments before using.

**Caution:** Do not use temperature settings over 121°C (250°F). Specifically, do not use higher temperature settings for shorter periods of time (known as "flash" autoclaving), as this may damage the instruments. Be sure that the autoclave is set to the correct parameters before autoclaving.

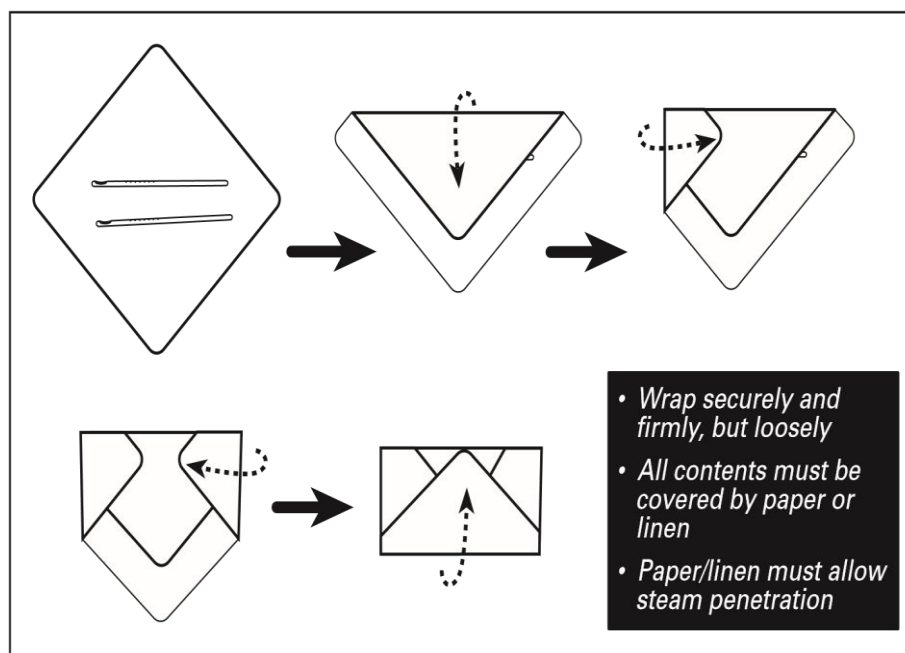

**Paper wrap**

#### *Steps to sterilize using glutaraldehyde*

1. Completely immerse the instruments so that the solution fills them completely.
2. Soak in glutaraldehyde solution for the time recommended by the manufacturer—for example, 10 hours for Cidex.
3. Remove with sterile gloves or forceps.
4. Rinse all parts with sterile water. Do not use tap water to rinse.
5. Dry with a sterile cloth, if desired.
6. Change the solution according to the manufacturer's instructions. Generally, glutaraldehyde has a 14-day shelf-life after being activated, but it should be discarded sooner if the solution becomes cloudy. Do not use below 25°C (77°F).

Once instruments have been sterilized, anything that subsequently comes in contact with them must also be sterile, for example, gloves or a storage container.

#### *Steps to high-level disinfect by boiling*

1. Place the instruments in water at a rolling boil. Items do not need to be fully immersed.
2. Boil for 20 minutes.
3. Remove using HLD or sterile gloves or forceps.
4. Dry with a sterile cloth, if desired.
5. Cool before use. Handle the cannulae by the base ends when removing. Grasping hot instruments may cause flattening. The boiling process may discolor cannulae without affecting their function. (Boiling is an appropriate method of HLD for Ipas MVA Plus instruments. Do not boil Ipas single-valve or double-valve aspirators.)

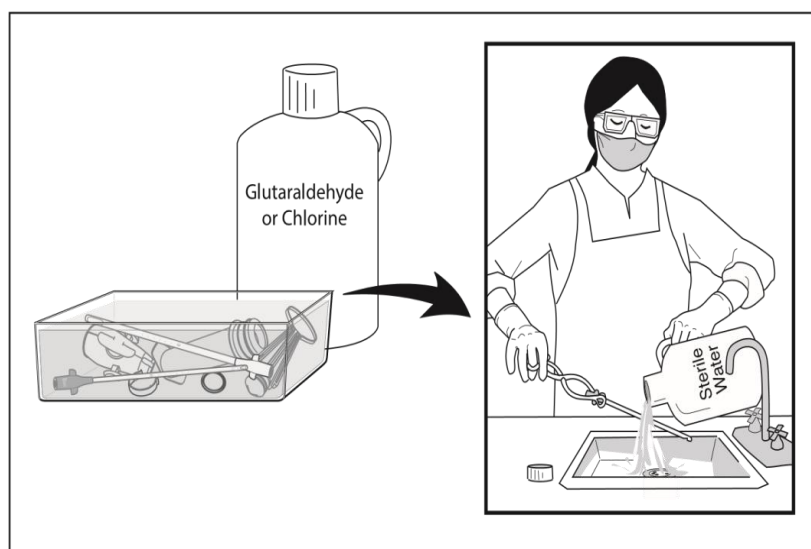

HLD soak and rinse

### *Steps to high-level disinfect using glutaraldehyde*

1. Completely immerse instruments so that the solution fills them completely.
2. Soak in solution for the time recommended by the manufacturer – for example, 20 minutes for Cidex.
3. Remove from solution using HLD or sterile gloves or forceps.
4. Rinse all parts with sterile or boiled water.
5. Dry with a sterile cloth, if desired.
6. Change the solution according to manufacturer's instructions – every 14 days or sooner if the solution becomes cloudy.

### *Steps to high-level disinfect using a 0.5% chlorine soak*

1. Completely immerse instruments so that the solution fills them completely. Use a plastic (non-metal) container.
2. Soak in a 0.5% chlorine solution for 20 minutes.
3. Remove from solution using HLD or sterile gloves or forceps.
4. Rinse all parts with sterile or boiled water.
5. Dry with a sterile cloth, if desired. Chlorine solution should be changed daily or sooner if it becomes cloudy.

## 3.5 Assembly and lubrication of the aspirator

Aspirators should be reassembled after processing and once dry. The plunger O-ring should also be lubricated before reassembly. They must be correctly assembled after processing in order to function properly. To assemble the Ipas MVA Plus aspirator:

1. Place the valve liner in position inside the valve by aligning the internal ridges. Close the valve until it snaps in place.
2. Snap the cap into place on the end of the valve.
3. Push the cylinder into the base of the valve.
4. Place the plunger O-ring in the groove at the end of the plunger and lubricate it by spreading one drop of lubricant around the O-ring with a fingertip. Silicone, which is not sterile, is provided with the aspirator; other non-petroleum based lubricants can also be used.

**Caution:** Excessive lubrication can cause the aspirator to lose vacuum. Do not over-lubricate the plunger O-ring. Do not lubricate other parts of the aspirator.

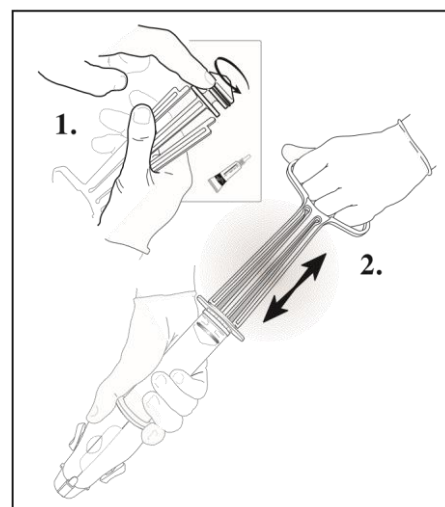

Steps to lubrication

5. When reassembling the aspirator, ensure that the plunger is introduced straight into the cylinder and not introduced at an angle.
6. Squeeze the plunger arms and fully insert the plunger into the cylinder.
7. Move the plunger in and out to lubricate the cylinder.
8. Insert the tabs of the collar stop into the holes in the cylinder so that the plunger cannot be pulled out of the cylinder.

Always check that the aspirator retains a vacuum before using it. See Section 2.4 for instructions on how to check for vacuum retention.

### 3.6 Storage of instruments

Instruments should be stored in an environment that preserves the level of processing desired. However, it is important to note that the aspirator and the cannula can be stored differently.

The aspirator can be stored in a clean, dry place. The cannula needs to remain sterile or HLD. This is because the aspirator does not directly touch the inside of a woman's body but the cannula does.

The aspirator can be stored in a clean dry place or a clean container protected from dust and other contaminants until the next use. If all the parts are dry, reassemble the aspirator for storage using clean gloves or clean hands.

Storage of the cannula depends on the processing method: If steam autoclaved, the cannula needs to remain sterile until next use.

If sterilized by glutaraldehyde soak, the cannula needs to be stored in a sterile container to maintain sterility, but *should be reprocessed if not used that day*. If HLD with boiling or chemicals, the cannula needs to be stored in a HLD container to maintain high-level disinfection, but *should be reprocessed if not used that same day*.



This is because items that have been processed using wet methods are more prone to microbial growth as there is often no efficient way to dry items that have been processed by wet methods.

### 3.7 Disposal and replacement

When disposing of contaminated Ipas aspirators and cannulae, dispose as infectious waste. If any of the following have occurred, the instruments should be discarded and replaced:

#### *Aspirators:*

- Cylinder has become cracked or brittle;
- Valve parts have become cracked, bent or broken;
- Buttons have broken;
- Plunger arms no longer lock;
- Aspirator no longer holds a vacuum;
- Mineral deposits inhibit the plunger movement.

#### *Cannulae:*

- Cannula has become brittle;
- Cannula has become cracked, twisted or bent, particularly around the aperture;
- Tissue cannot be removed during the cleaning process.

#### **Disinfectants used in processing Ipas instruments**

*Any chemical that kills microorganisms is a germicide. Strong germicides called disinfectants are used for cleaning equipment. Weaker germicides called antiseptics are used on people. Antiseptics should not be used for cleaning or processing instruments and equipment, as they are not strong enough to be effective. The following agents should not be used for instrument processing: formaldehyde solution, which is toxic; formalin chambers, which are ineffective; and hydrogen peroxide, which is light sensitive.*

*A 0.5% chlorine solution can be used for the decontamination soak and high-level disinfection of instruments, and can also be used as a general all-purpose cleaning solution for the clinical equipment and environment. This mixture of sodium hypochlorite (bleach) or other chlorine compounds, such as calcium hypochlorite, is a strong disinfectant for many objects, as well as typically inexpensive. The correct concentration can easily be mixed using a locally available agent and water. (Please see Appendix B: Methods for processing Ipas MVA Plus aspirators and adaptors and Ipas EasyGrip® cannulae.)*

*Health-care workers should use different buckets of 0.5% chlorine solution for soaking, high-level disinfecting and general cleaning. The same bucket of solution should not be used for more than one purpose.*

## 4.0 Summary

- The Ipas MVA Plus aspirator is composed of a valve body, plunger, a 60cc cylinder and a collar stop.
- Ipas EasyGrip cannulae are available in sizes 4, 5, 6, 7, 8, 9, 10, and 12 mm, have either one aperture (9, 10 and 12mm sizes) or two apertures (4, 5, 6, 7 and 8mm sizes), and do not require separate adapters.
- Both the MVA Plus aspirator and the Ipas EasyGrip cannulae are steam-autoclavable.
- Ipas 3mm cannulae are for single-use in endometrial biopsy procedures and require an adaptor when used with the MVA Plus aspirator.
- Clinical indications for uterine aspiration with Ipas MVA Plus and Ipas EasyGrip cannulae are: treatment of incomplete abortion for uterine sizes up to 12 weeks since LMP, first-trimester abortion and endometrial biopsy.
- Endometrial biopsy should not be performed in cases of suspected pregnancy. There are no known contraindications for other clinical indications.
- Providers should be able to prepare a vacuum, check vacuum retention, and start and stop suction.
- After cleaning, aspirators and cannulae must undergo sterilization or high-level disinfection between patients to remove contaminants.
- After fully processing, aspirators do not need to remain sterile or high-level disinfected until next use. They can be kept in a clean place. Cannulae must remain sterile or high-level disinfected until next use.
- Protocols for processing must be appropriate for the specific aspirators and cannulae in use.
- Processing options for sterilizing instruments are: autoclaving or glutaraldehyde.
- Processing options for high-level disinfecting instruments are: boiling, glutaraldehyde, or 0.5% chlorine solution.
- The plunger O-ring must be lubricated with one drop of lubricant after processing.
- Proper handling and storage are essential to maintaining the sterility or high-level disinfection of instruments.
- Instruments that are worn out or damaged should be discarded or replaced.

## References

Rutala, W. A., & Weber, D. J. (2010). An overview of disinfection and sterilization. In W. A. Rutala (Ed.), *Disinfection, Sterilization and Antisepsis: Principles, Practices, Current Issues, New Research, and New Technologies*. Washington, DC: Association for Professionals in Infection Control and Epidemiology (APIC).

World Health Organization. (2012). *Safe abortion: Technical and policy guidance for health systems*. Geneva: World Health Organization.

World Health Organization (WHO). (2007). *Standard precautions in health care*. Retrieved from [http://www.who.int/csr/resources/publications/EPR\\_AM2\\_E7.pdf](http://www.who.int/csr/resources/publications/EPR_AM2_E7.pdf).

## Appendix A: Comparison of Ipas Instruments

The charts below highlight design features and compatibility between Ipas aspirators and cannulae.

Characteristic	Ipas MVA Plus	Ipas Single-Valve	Ipas Double-Valve
<b>Holding capacity</b>	60cc	60cc	60cc
<b>Suction capacity</b>	24-26 inches (609.6-660.4mm) of mercury	24-26 inches (609.6-660.4mm) of mercury	24–26 inches (609.6-660.4mm) of mercury
<b>Compatibility with Ipas cannulae</b>	<ul style="list-style-type: none"> <li>Compatible with Ipas EasyGrip cannulae, all sizes, no adapters needed</li> <li>Compatible with all sizes of flexible Karman cannulae; 12mm does not require separate adapter</li> <li>Compatible with the Ipas 3mm cannula; requires 6mm adapter</li> </ul>	<ul style="list-style-type: none"> <li>Not compatible with Ipas EasyGrip cannulae</li> <li>Compatible with flexible Karman cannulae, sizes 4, 5,6mm only; no separate adapters needed</li> <li>Compatible with the Ipas 3mm cannulae; no separate adapters needed</li> </ul>	<ul style="list-style-type: none"> <li>Compatible with Ipas EasyGrip cannulae, all sizes, no adapters needed</li> <li>Compatible with all sizes of flexible Karman cannulae; 12mm does not require separate adapter</li> <li>Compatible with the Ipas 3mm cannula; requires 6mm adapter</li> </ul>
<b>Processing methods*</b>	<ul style="list-style-type: none"> <li>Must be high-level disinfected or sterilized between uses</li> <li>High-level disinfection (HLD) with               <ul style="list-style-type: none"> <li>0.5% chlorine ▲</li> <li>HLD by boiling</li> <li>HLD with Cidex® / glutaraldehyde ▲</li> <li>HLD with Cidex OPA ▲</li> <li>HLD with Sporox® I ▲</li> </ul> </li> <li>Sterilization with steam autoclave (250° F; 121°C)</li> <li>Sterilization with Cidex® / glutaraldehyde ▲</li> <li>Sterilization with STERRAD®100S</li> <li>Sterilization with SporoxII ▲</li> </ul>	<ul style="list-style-type: none"> <li>Must be high-level disinfected or sterilized between uses</li> <li>High-level disinfection (HLD) with 0.5% chlorine ▲</li> <li>DO NOT BOIL</li> <li>HLD with Cidex® / glutaraldehyde ▲</li> <li>HLD with CidexOPA ▲</li> <li>HLD with Sporox® II ▲</li> <li>DO NOT USE IN STEAM AUTOCLAVE</li> <li>Sterilization with Cidex® / glutaraldehyde ▲</li> <li>Sterilization with SporoxII ▲</li> </ul>	SINGLE USE ONLY
<b>Valve design</b>	<ul style="list-style-type: none"> <li>Valve liner is removable by opening hinged valve body</li> <li>2 valve buttons</li> </ul>	<ul style="list-style-type: none"> <li>Valve liner is removable</li> <li>1 valve button</li> </ul>	<ul style="list-style-type: none"> <li>Valve liner is not removable</li> <li>2 valve buttons</li> <li>Valve O-ring required</li> </ul>
<b>Cylinder design</b>	Collar stop must be displaced or removed for processing	Collar stop must be removed for processing	SINGLE USE ONLY
<b>Plunger design</b>	<ul style="list-style-type: none"> <li>Plunger O-ring must be displaced or removed for processing</li> <li>Ergonomic handle</li> </ul>	Plunger O-ring must be displaced or removed for processing	SINGLE USE ONLY

\* The Ipas MVA Plus and the Ipas Single-Valve Aspirator must be HIGH-LEVEL DISINFECTED OR STERILIZED BETWEEN USES.

▲ Liquid processing agents are hazardous substances. When processing instruments, take necessary precautions, such as using personal protective equipment. Refer to manufacturer's safety instructions to establish safe use.

## Appendix B: Methods For Processing Ipas MVA Plus Aspirators and Adaptors, and Ipas EasyGrip Cannulae

Processing of Ipas Aspirators			
Method	Agent	Time	Precautions
High-Level Disinfect (HLD)	<b>Chlorine ▲</b> Dilute to 0.5%.	20 minutes	<ul style="list-style-type: none"> <li>• Completely immerse disassembled parts.</li> <li>• After processing, rinse all parts with sterile or boiled water. Discard solution daily or sooner if solution becomes cloudy.</li> </ul>
	<b>Boiling water*</b> (Ipas MVA Plus and Adaptors only)	20 minutes	<ul style="list-style-type: none"> <li>• Disassembled parts do not need to be fully immersed.</li> <li>• Bring to room temperature before use.</li> </ul>
	<b>2% Glutaraldehyde (Cidex®) ▲</b> Follow manufacturer's Instructions for mixing.	20 minutes or follow manufacturer's instructions	<ul style="list-style-type: none"> <li>• Completely immerse disassembled parts.</li> <li>• After processing, rinse all parts with sterile or boiled water. Discard solution 14 days after mixing or sooner if solution becomes cloudy.</li> <li>• Do not use below 77°F (25°C).</li> </ul>
	<b>Glutaraldehyde (other solutions) ▲</b> Follow manufacturer's Instructions for mixing.	Follow manufacturer's instructions	<ul style="list-style-type: none"> <li>• Completely immerse disassembled parts.</li> <li>• After processing, rinse all parts with sterile or boiled water.</li> <li>• Usually discard solution 14 days after mixing or sooner if solution becomes cloudy.</li> </ul>
	<b>Sporoxil ▲</b>	30 minutes	<ul style="list-style-type: none"> <li>• Completely immerse disassembled parts.</li> <li>• After processing, rinse all parts with sterile or boiled water.</li> <li>• Discard solution 21 days or sooner as indicated by results from SPOROX® test vials.</li> <li>• Use at 68°F (20°C).</li> </ul>
	<b>Cidex OPA ▲</b>	12 minutes	<ul style="list-style-type: none"> <li>• Completely immerse disassembled parts.</li> <li>• After processing, rinse all parts with sterile or boiled water.</li> <li>• Discard solution 14 days or sooner as indicated by Cidex OPA solution test strips.</li> <li>• Do not use below 68°F (20°C).</li> </ul> <p><i>Note: Cidex OPA will discolor the liners of the Ipas MVA Plus and the Single-valve aspirator.</i></p>

# Ipas aspirators must be HIGH-LEVEL DISINFECTED OR STERILIZED BETWEEN USES.

\* **CAUTION:** Never boil or steam autoclave the plungers from the Ipas Single-Valve aspirator, as they will emit formaldehyde. Do not interchange plungers between aspirator types.

▲ Liquid processing agents are hazardous substances. When processing instruments, take necessary precautions, such as using personal protective equipment. Refer to the manufacturer's safety instructions to establish safe use.

## Appendix B: Methods for processing Ipas MVA Plus aspirators and adaptors and Ipas EasyGrip cannulae (*continued*)

Processing of Ipas Aspirators			
Method	Agent	Time	Precautions
Sterilize	<b>Steam autoclave*</b> <b>(Ipas MVA Plus and Adapters only)</b>	<ul style="list-style-type: none"> <li>• Sterility is achieved at 121°C (250°F) for 30 minutes with pressure of 106kPa (15lbs/in<sup>2</sup>)</li> <li>• Do not use other autoclave settings.</li> <li>• Specifically, do not use higher settings for shorter periods of time (known as “flash autoclaving”).</li> </ul>	<ul style="list-style-type: none"> <li>• Place the disassembled aspirator in linen or paper.</li> <li>• Steam must penetrate all surfaces. Parts should not touch and should be arranged so openings are not obstructed, permitting drainage.</li> <li>• With the Ipas MVA Plus, the collar stop must be completely removed (not held with the retaining clip).</li> <li>• Bring to room temperature before use.</li> </ul>
	<b>2% Glutaraldehyde (Cidex®) ▲</b> Follow manufacturer’s Instructions for mixing.	10 hours	<ul style="list-style-type: none"> <li>• Completely immerse disassembled parts.</li> <li>• After processing, rinse all parts with sterile water. Usually discard solution 14 days after mixing or sooner if solution becomes cloudy.</li> </ul>
	<b>Glutaraldehyde (other solutions) ▲</b> Follow manufacturer’s Instructions for mixing.	Follow manufacturer’s instructions.	<ul style="list-style-type: none"> <li>• Completely immerse disassembled parts. After processing, rinse all parts with sterile water.</li> <li>• Usually discard solution 14 days after mixing or sooner if solution becomes cloudy.</li> </ul>
	<b>STERRAD® 100S</b> (Ipas MVA Plus and adapters only)	55 minutes	<ul style="list-style-type: none"> <li>• Place the disassembled aspirator along with a chemical indicator strip in an approved tray or peel pack.</li> </ul>
	<b>SporoxII ▲</b>	6 hours	<ul style="list-style-type: none"> <li>• Completely immerse disassembled parts.</li> <li>• After processing, rinse all parts with sterile water.</li> <li>• Discard solution 21 days or sooner as indicated by results from SPOROX® test vials. Use at 68°F (20°C).</li> </ul>

# Ipas aspirators must be HIGH-LEVEL DISINFECTED OR STERILIZED BETWEEN USES.

\* **CAUTION:** Never boil or steam autoclave the plungers from the Ipas Single-Valve aspirator, as they will emit formaldehyde. Do not interchange plungers between aspirator types.

▲ Liquid processing agents are hazardous substances. When processing instruments, take necessary precautions, such as using personal protective equipment. Refer to the manufacturer’s safety instructions to establish safe use.

## Appendix B: Methods for processing Ipas MVA Plus aspirators and adaptors and Ipas EasyGrip cannulae (*continued*)

Processing Ipas EasyGrip Cannulae			
Method <sup>#</sup>	Agent	Time	Precautions
High-Level Disinfect (HLD)	<b>Chlorine ▲</b> Dilute to 0.5%.	20 minutes	<ul style="list-style-type: none"> <li>• Items must be fully immersed.</li> <li>• Discard solution daily or sooner if solution becomes cloudy.</li> <li>• After processing, rinse all parts with sterile or boiled water.</li> </ul>
	<b>Boiling water</b>	20 minutes	<ul style="list-style-type: none"> <li>• Items do not need to be fully immersed.</li> <li>• Cannulae may discolor without affecting function.</li> <li>• Grasping hot cannulae may cause flattening.</li> <li>• Let water cool before removing cannulae and handle by the adapter/base end.</li> </ul>
	<b>2% Glutaraldehyde (Cidex®) ▲</b> Follow manufacturer's Instructions for mixing.	20 minutes or follow manufacturer's instructions	<ul style="list-style-type: none"> <li>• Items must be fully immersed.</li> <li>• Discard solution 14 days after mixing or sooner if solution becomes cloudy.</li> <li>• Do not use below 77°F (25°C).</li> <li>• After processing, rinse all parts with sterile or boiled water.</li> </ul>
	<b>Glutaraldehyde (other solutions) ▲</b> Follow manufacturer's Instructions for mixing.	Follow manufacturer's instructions	<ul style="list-style-type: none"> <li>• Items must be fully immersed.</li> <li>• Usually discard solution 14 days after mixing or sooner if solution becomes cloudy.</li> <li>• After processing, rinse all parts with sterile or boiled water.</li> </ul>
	<b>SporoxII ▲</b>	30 minutes	<ul style="list-style-type: none"> <li>• Items must be fully immersed.</li> <li>• After processing, rinse all parts with sterile or boiled water.</li> <li>• Discard solution 21 days or sooner as indicated by results from SPOROX® test vials. Use at 68°F (20°C).</li> </ul>
	<b>Cidex OPA ▲</b>	12 minutes	<ul style="list-style-type: none"> <li>• Items must be fully immersed.</li> <li>• After processing, rinse all parts with sterile or boiled water.</li> <li>• Discard solution 14 days or sooner as indicated by Cidex OPA solution test strips.</li> <li>• Do not use below 68°F (20°C).</li> </ul> <p><b>Note:</b> Cidex OPA will discolor the liners of the Ipas MVA Plus and the single-valve aspirator.</p>

<sup>#</sup> Ipas EasyGrip cannulae must be HIGH-LEVEL DISINFECTED OR STERILIZED BETWEEN USES.

▲ Liquid processing agents are hazardous substances. When processing instruments, take necessary precautions, such as using personal protective equipment. Refer to the manufacturer's safety instructions to establish safe use.

In addition to these options for sterilization and high-level disinfection, Ipas EasyGrip cannulae can be sterilized with ethylene oxide (ETO). The Ipas MVA Plus® aspirator should not be processed with this method.

## Appendix B: Methods for processing Ipas MVA Plus aspirators and adaptors and Ipas EasyGrip cannulae (*continued*)

Processing Ipas EasyGrip Cannulae			
Method <sup>#</sup>	Agent	Time	Precautions
Sterilize	<b>Steam autoclave*</b>	<p>Sterility is achieved at 121°C (250°F) for 30 minutes with pressure of 106kPa(15 lbs/ in2).</p> <p>Do not use other auto-clave settings. Specifically, do not use higher settings for shorter periods of time (known as “flash autoclaving”).</p>	<ul style="list-style-type: none"> <li>• Steam must penetrate all surfaces. Parts should not touch and should be arranged so openings are not obstructed, permitting drainage.</li> <li>• Ipas EasyGrip cannulae, particularly the smaller sizes, may curve in steam autoclaves. To minimize this, package them by wrapping in paper or linen, and lay the package flat along the side or on the bottom of the autoclave.</li> <li>• Be sure no other objects in the autoclave are positioned to cause bending of the cannulae.</li> </ul>
	<b>2% Glutaraldehyde (Cidex) ▲</b> Follow manufacturer’s instructions for mixing.	10 hours	<ul style="list-style-type: none"> <li>• Items must be fully immersed.</li> <li>• Discard solution 14 days after mixing or sooner if solution becomes cloudy.</li> <li>• Do not use below 77°F (25°C). After processing, rinse all parts with sterile water.</li> </ul>
	<b>Glutaraldehyde (other solutions) ▲</b> Follow manufacturer’s instructions for mixing.	Follow manufacturer’s instructions.	<ul style="list-style-type: none"> <li>• Items must be fully immersed.</li> <li>• Usually discard solution 14 days after mixing or sooner if solution becomes cloudy.</li> <li>• After processing, rinse all parts with sterile water.</li> </ul>
	<b>Sporoxil ▲</b>	6 hours	<ul style="list-style-type: none"> <li>• Items must be fully immersed.</li> <li>• Discard solution 21days or sooner as indicated by results from SPOROX test vials.</li> <li>• Use at 68°F (20°C). After processing, rinse all parts with sterile water.</li> </ul>

<sup>#</sup> Ipas EasyGrip cannulae must be HIGH-LEVEL DISINFECTED OR STERILIZED BETWEEN USES.

▲ Liquid processing agents are hazardous substances. When processing instruments, take necessary precautions, such as using personal protective equipment. Refer to the manufacturer’s safety instructions to establish safe use.

In addition to these options for sterilization and high-level disinfection, Ipas EasyGrip cannulae can be sterilized with ethylene oxide (ETO). The Ipas MVA Plus<sup>®</sup> aspirator should not be processed with this method.



# Uterine Evacuation Procedure with Ipas MVA Plus

## Key topics in this module:

- Preparation for an MVA procedure
- Pain management
- Uterine evacuation procedure with Ipas MVA Plus
- Post-procedure care
- Follow-up care
- Special considerations: Young women

## 1.0 Introduction

The objective of this module is to explain the steps involved in a manual vacuum aspiration (MVA) procedure using the Ipas MVA Plus aspirator and Ipas EasyGrip cannulae, which are now manufactured and distributed globally by WomanCare Global.

WomanCare Global (WCG) is a nonprofit organization working with partners around the world to improve the lives of women by providing access to affordable, quality reproductive health products. For more information, see [www.womancareglobal.org](http://www.womancareglobal.org).

PAC treatment can be an emergency situation, and the woman's condition can change quickly at any point during her care. The provider should remain alert for changes in the patient's emotions and physiology throughout the procedure, as these changes may indicate complications.

## 2.0 Preparation

Before the MVA procedure:

- Provide counseling to the woman and obtain informed consent (Please see the Informed Consent, Information and Counseling module.)
- Perform a clinical assessment, including physical examination (Please see the Clinical Assessment module.)
- Discuss her contraceptive needs (Please see the Contraceptive Services module.)

### 2.1 Explaining the MVA process to women

Before the procedure, the woman should receive instructions about what she may experience, when to follow up, and when and where to seek medical help in case of a problem. Because some words are probably unfamiliar to her, providers should use simple language. Thorough information on what the woman might expect helps her to be prepared. Reassurance and support during the uterine evacuation process can also be helpful. (Please see the Informed Consent, Information and Counseling module.)

### 2.2 Clinical assessment: Physical examination

Clinical assessment prior to uterine evacuation with MVA Plus includes gestational dating, assessment of uterine size, assessment of the woman's general health and any contraindications or precautions.

#### *Precautions prior to performing an MVA procedure*

Before beginning, it is important that the provider confirm the uterine size and position to ensure that MVA is the most appropriate method for uterine evacuation. Large fibroids or uterine anomalies may make it difficult to determine the size of the uterus and to perform intrauterine procedures, including MVA. Therefore, providers should be well-trained in determining length of pregnancy prior to using MVA. Ultrasound examination in such situations, obese women and when ectopic pregnancy is suspected may help managing the woman. Prophylactic antibiotics should be administered prior to the VA procedure. (Please see the Clinical Assessment module.)

There are no known contraindications to providing uterine evacuation with MVA Plus.

#### **Sample pain-management plan**

- *Oral analgesics administered 30 minutes prior to the MVA procedure*
- *Paracervical block*
- *Non-pharmacological approaches, such as verbal reassurance and gentle clinical technique*

## 2.3 Contraceptive needs

A woman may ovulate almost immediately after an MVA procedure. Therefore, all women who do not wish to become pregnant should leave the facility with an effective method of contraception. If a woman desires long acting contraception or sterilization but it cannot be provided, an interim method should be given and referral made to the appropriate facility. In general, all modern contraceptive methods can be used immediately following first-trimester MVA provided that there are no contraindications. Fertility awareness-based methods should only be used after a woman has had at least one postabortion menses and only if she had regular menstrual cycles prior to the uterine evacuation. IUDs, implants and injectables may be given in the procedure room. (Please see the Contraceptive Services module.)

## 3.0 Pain management

Most women requiring postabortion care treatment may be experiencing pain related to the complications or will experience pain during the procedure. Providers consistently underestimate the amount of pain a woman experiences during vacuum aspiration. All women who present for postabortion care should be offered pain management and provided these services without delay. Providers should always offer gentle, respectful care and provide appropriate information, which can help women stay calm and reduce anxiety and pain.

Most of the recommendations on pain management for vacuum aspiration are based on studies of first-trimester abortion. However, the same principles and recommendations apply to uterine evacuation for postabortion care.

### 3.1 Factors influencing pain for women receiving postabortion care

While most women feel pain during a vacuum aspiration procedure, each woman is unique and there is great variation in their experiences of pain. Providers should avoid stereotypes or assumptions about a woman's pain threshold. Pain management should address both the physical aspects of pain as well as the psychosocial contributors. Physical aspects that have been associated with increased pain during vacuum aspiration include nulliparity, young age, higher gestational age, and dysmenorrhea. Psychosocial elements such as anxiety and depression have also been associated with increased pain. Aspects of the procedure that can affect pain levels include cervical dilatation, uterine manipulation, the skill and clinical technique of the provider, and the physical environment. Although some women may have a higher pain tolerance, each woman still needs to be offered and given pain management. It is her choice to refuse it if desired.

### 3.2 Pain-management plan

Prior to performing the procedure, the provider should create a pain-management plan with the woman. The purpose of the plan is to reduce any physical pain and anxiety and minimize medication-induced risks and side effects.

During a uterine evacuation, pain can be reduced with a combination of verbal support, oral medications, paracervical block, skilled and gentle clinical technique, and calming environment. Conscious sedation is an option in centers where it is offered. General anesthesia increases the risk of complications and is not recommended for routine procedures.

- Explain that the MVA procedure usually lasts less than 10 minutes but during that time and perhaps afterwards she will experience some discomfort.
- Discuss various options available to reduce pain, along with their potential side effects.
- Decide on a pain-management plan together, giving the woman control over which methods to use. Providers can increase client satisfaction by allowing the woman to select the method that best fits her individual circumstances.

Each health-care facility should develop a feasible protocol for pain management based on supplies that are available.

### 3.3 Non-pharmacological methods for pain management

Non-pharmacological methods, including verbal and physical reassurance, gentle clinical technique and calming environment, can decrease a woman's anxiety and perception of pain, and should be considered for every MVA procedure. The woman's perception of pain is strongly affected by her level of anxiety and the amount of information she receives about the procedure. Respectful, supportive care by staff helps reduce anxiety and decrease pain, and should be a standard part of care. Providers can ask which supportive measures a woman prefers. A woman may feel more relaxed and comfortable if a nurse, assistant or companion accompanies her during the procedure. The provider and her companion should ask her in advance about her preference for support measures they will offer.

#### *Verbal and physical reassurance*

Verbal and physical reassurance before, during and after the procedure may help some women relax.

Some programs and providers use the term "verbacaine" or "vocal anesthetic" for the process of verbal reassurance. **Verbal reassurance, however, is not a substitute for pharmacological methods of pain control, but a useful supplement to them.** A woman may desire silence or distracting conversation, or information about each step of the procedure before it occurs. For example, the provider should let her know that the cramping she feels toward the end of the procedure indicates that the procedure is almost complete. The provider should also determine her preference for physical touch, such as holding her hand or rub her arm.



*Provide verbal reassurance*

**Positive statements for verbal reassurance by the health-care team**

*“What can I do that would be most helpful to you?”*

*“What do you imagine will be the most difficult part of this for you?”*

*“I can’t promise that it won’t hurt, but I can promise you that the procedure will be done as gently as possible.”*

*“I’ll be right beside you, and you can squeeze my hand during the procedure.”*

*(Adapted from Stewart et al., 2002)*

*Gentle clinical technique*

The provider should always be gentle during physical contact with the woman, ensuring that instruments are at a comfortable temperature. As instruments are inserted and moved, providers should use smooth motions and gentle technique. It is important for providers to inform the woman that they are going to touch her and explain what she is going to feel, before performing the action. Movements that are jerky or sudden can cause the woman additional discomfort.

*Calming environment*

Facility staff can create a calming environment by providing appropriate music, lighting, and décor. Music is effective for pain management in uterine evacuation with VA and may be helpful for uterine evacuation with misoprostol as well.

### 3.4 Pharmacological methods for pain management

*Oral medications*

Premedication with non-steroidal analgesics such as ibuprofen or naproxen has been shown in clinical trials to decrease pre- and post-procedure pain. In addition, premedication with oral anxiolytics such as lorazepam may be of benefit to some women but clinical trial evidence does not support its routine use.

*Local anesthesia*

A paracervical block with 20mL of xylocaine 1% given three minutes before dilating the cervix has been shown to decrease pain with dilation and aspiration. Paracervical block is a low risk procedure that can be performed by physicians and midlevel providers prior to vacuum aspiration.

*Conscious sedation*

Conscious sedation using a combination of intravenous medications such as fentanyl and midazolam is an effective means of pain control and improves satisfaction with the uterine evacuation procedure. However, providing conscious sedation increases the expense,

complexity and potential risks of a uterine evacuation procedure. Increased monitoring requires facility investments in training and equipment to deliver conscious sedation safely.

(Please see Appendix A: Pharmacologic Approaches to pain management during MVA.) Any medication administered to the woman should be in full effect by the time the procedure starts. The provider should continually monitor and manage medication induced side effects and complications.

### 3.5 Post-procedure pain management

Some pain is normal following even uncomplicated uterine aspiration procedures because the uterus is contracting. Pain that increases over time requires clinical evaluation. Analgesics like ibuprofen can help relieve cramping pain. Narcotics are usually not necessary. If narcotics or other strong pain medications were given before, during or after the uterine evacuation procedure, close monitoring may be necessary depending on the route, dose and type of drug given. Providers should inform women about all their choices for pain management in the post-procedure period and provide them with instructions about how to take any pain medications that they receive. See Section 5.0 of this module for more information.

(Please see Appendix A: Pharmacologic approaches to pain management during MVA for more information about pain medication options.)

## 4.0 Uterine evacuation procedure

### *Steps for performing MVA*

1. Prepare instruments
2. Prepare the woman
3. Perform cervical antiseptic prep
4. Perform paracervical block
5. Dilate cervix
6. Insert cannula
7. Suction uterine contents
8. Inspect tissue
9. Perform any concurrent procedures
10. Take immediate post-procedure steps, including instrument processing

## 4.1 Steps for performing MVA

### *Step 1: Prepare instruments*

The provider should check the aspirator for vacuum retention before beginning the MVA procedure, and then create a vacuum for evacuation during the procedure. (Please see the Ipas MVA Instruments Module.)

When the uterine contents are likely to be copious, as in cases of hydatidiform mole, it can be helpful to have more than one aspiration device ready for use. It is also useful to have a back-up aspirator readily available in case the first aspirator has technical problems. Alternately, the provider should be prepared to quickly empty and recharge one MVA aspirator, as needed. (Please see Appendix B: Suggested equipment and supplies for uterine evacuation procedure with Ipas MVA Plus.)

### *Step 2: Prepare the woman*

Administer pain medication to have maximum effect when procedure begins. Give prophylactic antibiotics to all women, and therapeutic antibiotics if indicated. Ask the woman to empty her bladder. Carefully help her onto the procedure table. Ensure that she is securely positioned and that she has given permission to start the procedure.

Wash hands and put on appropriate barriers, including gloves. Perform a bimanual examination to confirm or update findings of the earlier clinical assessment. It is crucial to have an accurate assessment of uterine size and position before performing a uterine evacuation.

Next, select a speculum. If a range of sizes are available, use the size appropriate to the woman and conducive to the exam or procedure. Insert the speculum.

### *Step 3: Perform cervical antiseptic prep*

Following the “no-touch technique” throughout, the provider should use an antiseptic-soaked sponge to clean the cervical os and, if desired, the vaginal walls. With each new sponge, start at the os and spiral outward. Continue until the os has been completely covered by antiseptic. Do not clean the cervix with the same gauze used for cleaning the vagina.

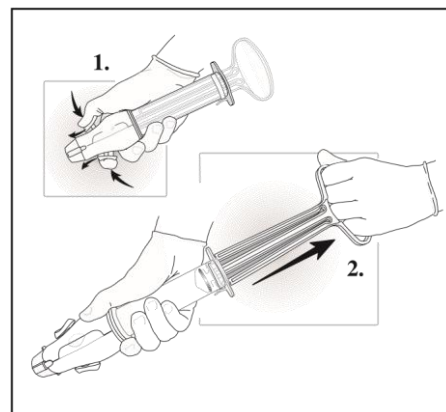

**Create a vacuum**

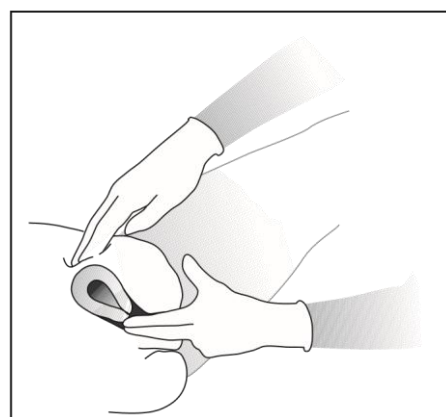

**Perform bimanual exam**

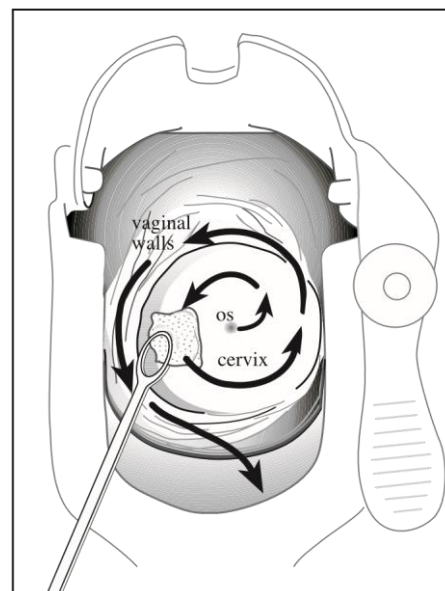

**Antiseptic cervical preparation**

**Step 4: Perform paracervical block**

In clinical practice, techniques for administering the paracervical block vary and are subject to provider preference. The following technique, with minor variations, has been used widely. To minimize clinical risk, use the lowest anesthetic dose possible, usually 10 to 20mL of 0.5-1% xylocaine solution. When using xylocaine, the recommended dose is less than 200mg/ person, as toxicity occurs at that level. The xylocaine solution should be inserted at the cervicovaginal junction, which marks the transition between the smooth cervical epithelium and vaginal tissue. Compared to cervical tissue, vaginal mucosa is more elastic and appears folded. After inserting the needle but before injecting any local anesthetic, always draw the plunger back slightly to ensure that the needle is not penetrating a blood vessel. If any blood is visible in the syringe, do not inject. Instead, move to a different injection site, and aspirate again before injecting.

**Step 5: Dilate cervix**

For postabortion care, a woman may have an open cervical os and not require dilatation. If the appropriate size cannula fits snugly through the os, no dilation is needed. However, cervical dilatation is an essential step if the cervix is closed or is not yet sufficiently dilated. (Please see the Ipas MVA Instruments module for more information about cannula sizes.)

It is essential to carefully examine the position of the uterus and cervix and to gently use instruments that accommodate the woman's anatomy. Dilate the cervix as necessary to allow a cannula approximate to the uterine size to fit snugly through the os.

The provider should dilate gently, never using force. Use mechanical dilators or progressively larger MVA cannulae, being careful not to tear the cervix or create a false opening. The tenaculum can be used to straighten the cervical os to allow for easier passage of the dilators.

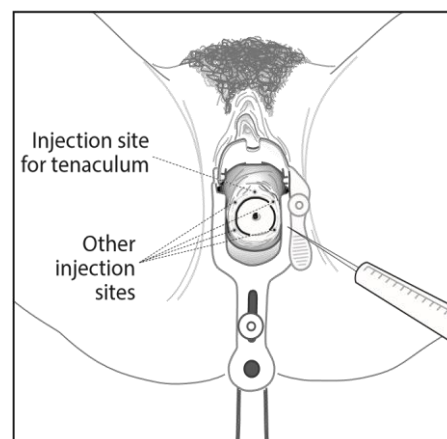
**Paracervical block****Paracervical block technique**

*This technique is recommended, as it has been shown to decrease pain of dilation and uterine aspiration:*

- Load a 20mL syringe with 1% xylocaine.
- Attach a 20 gauge spinal needle\* to the syringe.
- Inject 2mL superficially into the cervix at the site where the tenaculum will be placed (12 o'clock).
- Grasp the cervix with the tenaculum.
- Inject the remaining 18mL in equal amounts at the cervicovaginal junction at 2, 4, 8 and 10 o'clock. The injection is continuous from superficial to deep to superficial to a depth of 3cm. Always aspirate before injecting to prevent injecting into a vein.
- Dilation begins 3 minutes after the paracervical block is complete.

*\*Other needles may be used, such as a hypodermic needle or the needle from an IV insertion set.*

**Cervical dilatation**

*In cases of inevitable or incomplete abortion, the woman's cervix may be sufficiently open to perform uterine evacuation with minimal to no dilatation of the cervix. In cases of early fetal demise (missed abortion), dilatation is often required. Dilatation can be achieved by using either a physical instrument, such as a metal or plastic dilator, or a medication, such as misoprostol.*



Uterine perforation can occur, particularly if the provider miscalculates the position, size and depth of the cervix and uterus or uses force to insert instruments.

Women above 12-14 weeks should be given cervical preparation due to their increased need for cervical dilation. Misoprostol may be used for cervical preparation, if available. Cervical preparation may also be helpful for very young women or nulliparous women at lower gestational ages and may be used at the provider's discretion. (Please see Appendix C: Cervical preparation before first-trimester vacuum aspiration.)

#### *Step 6: Insert cannula*

While gently applying traction to the cervix, insert the cannula through the cervix, just past the cervical os and into the uterine cavity. Alternately, move the cannula slowly into the uterine cavity until it touches the fundus, and then withdraw it slightly. Rotating the cannula while gently applying pressure often helps insertion.

Do not insert the cannula forcefully through the cervical os into the uterus. Forceful movements may cause damage to the cervix or uterine perforation and damage to pelvic organs and blood vessels. Remain alert to signs that may indicate perforation throughout the procedure, and stop suction immediately if they appear.

#### *Step 7: Suction uterine contents*

Attach the prepared MVA aspirator to the cannula, holding the tenaculum and the end of the cannula in one hand and the aspirator in the other hand. Suction is started by releasing the buttons; suction will start immediately.

Evacuate the contents of the uterus by gently and slowly rotating the cannula 180 degrees in each direction, using an in-and-out motion. Blood and tissue will be visible entering the cylinder of the aspiration device through the cannula. It is important not to withdraw the opening of the cannula beyond the cervical os, as this will cause the vacuum to be lost. If this happens, or if the aspirator is full, detach cannula from aspirator and re-establish the vacuum.

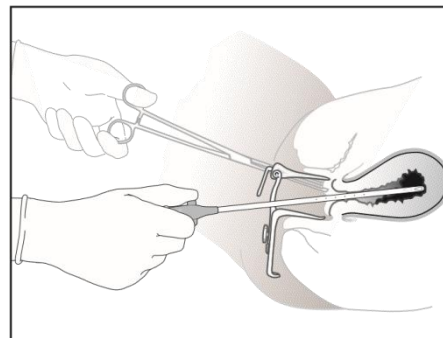

**Insert cannula**

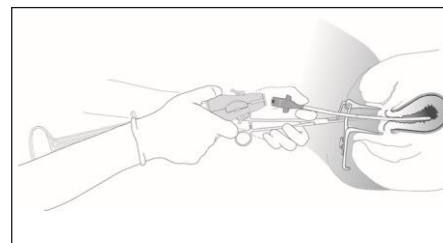

**Attach aspirator**

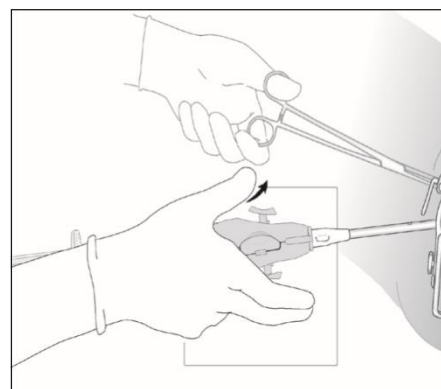

**Release buttons**

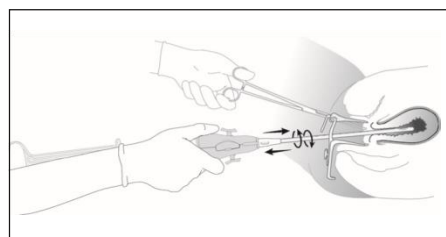

**Evacuate uterine contents**

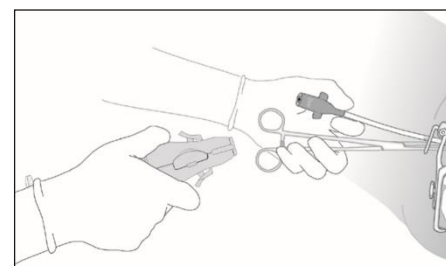

**Detach cannula from aspirator**

Be aware that Ipas EasyGrip cannulae fit firmly into the valve body and care should be used when disconnecting a cannula from the aspirator.

The following signs indicate that the uterus is empty:

- Red or pink foam appears and no more tissue is seen passing through the cannula;
- A gritty sensation is felt as the cannula passes over the surface of the evacuated uterus;
- The uterus contracts around (grips) the cannula;
- The woman complains of cramping or pain, indicating that the uterus is contracting.

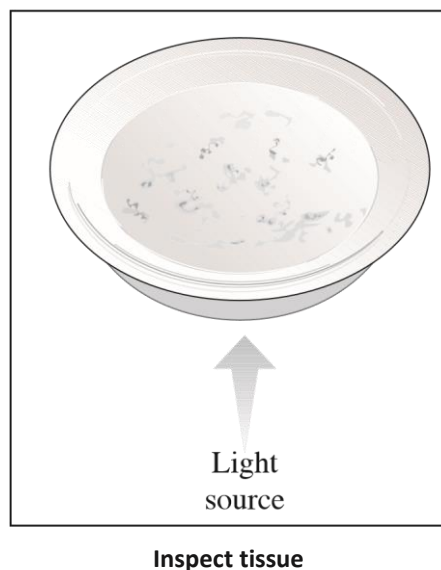

When the procedure is finished, depress the buttons and disconnect the cannula from the aspirator. The wings can aid in this action. Alternately, carefully withdraw the cannula and aspirator together without depressing the buttons. Keep the instruments available in case re-aspiration is required.

#### *Step 8: Inspect tissue*

Empty the contents of the aspirator into an appropriate container by removing the cannula, if still connected, releasing the buttons, if not pressed and gently pushing the plunger completely into the cylinder. Do not push aspirated contents through the cannula, as it will become contaminated. Keep the instruments ready in case further suction is required.

Inspect the tissue for these signs:

- The quantity and presence of products of conception (POC)
- Complete evacuation
- Molar pregnancy

If the visual inspection is not conclusive, the material should be strained, immersed in water or vinegar, and viewed with light from beneath. If indicated, tissue specimen may also be sent to a pathology laboratory. Villi and decidua should be visible in the tissue and the amount of tissue should correspond to the uterine size. In cases of molar pregnancy, grape-like chorionic villi are usually seen.

If no POC are visible, less tissue than expected was removed from the uterus or the tissue sample is inconclusive, this may indicate:

- *A spontaneous abortion* that has already completed itself
- *Continuing incomplete abortion*: The uterine cavity still contains POC, even though it appeared to be empty at the end of the procedure. This may result from using a cannula that is too small or stopping the procedure prematurely.

- *Suspected ectopic pregnancy:* When no villi or decidua are seen, ectopic pregnancy is a possibility and should be followed up on immediately.
- *Anatomical anomaly:* For example, in a bicornuate or septate uterus, the cannula may have been inserted into the side of the uterus that did not contain the pregnancy.

If it appears after tissue inspection that tissue may still be present in the uterus, re-evacuate the uterus.

Wipe the cervix clear with a clean swab to assess the amount of blood still coming from the uterus or any other source before removing the speculum. If significant bleeding continues or other issues are identified, the provider should intervene as needed. (Please see the Complications module.)

Use clinical judgment to determine if a bimanual exam will be necessary to check the size and firmness of the uterus.

#### *Step 9: Perform any concurrent procedures*

When the MVA procedure is complete, proceed with any contraceptive or other concurrent procedures to be conducted, such as inserting an IUD or implant, performing female sterilization or repairing a cervical tear. An IUD may be inserted immediately after an uncomplicated vacuum aspiration with no signs or symptoms of infection.

#### *Step 10: Take immediate post-procedure steps, including instrument processing*

When the uterine evacuation and any additional procedures are complete, providers should take the following steps:

- Immediately process or discard all instruments, including the aspirator and cannula, according to instrument processing procedures. (Please see the Ipas MVA Instruments module.)
- Remove barriers, such as gloves, and wash hands.
- Reassure the woman that the procedure is finished.
- Help her into a comfortable resting position on the table.
- Assist with moving her to the recovery area.
- Record information about the procedure, according to local protocol.

## 4.2 Solving instrument technical problems

The most common technical problem seen with MVA instruments is loss of vacuum. In most MVA procedures, the aspirator vacuum remains constant until the aspirator is approximately 80 percent, or 50mL, full. However, a decrease in vacuum may occur before the aspiration is complete for the following reasons:

- The aspirator is full;
- The cannula is withdrawn past the external os;

- The cannula becomes clogged;
- Incorrect assembly.

#### *Aspirator is full*

If the aspirator fills up so that suction stops:

- Press the buttons.
- Disconnect the aspirator from the cannula, leaving the cannula in place inside the uterus.
- Either empty the aspirator into a container by releasing the buttons and pushing the plunger into the cylinder or replace the aspirator.
- Re-establish vacuum in the aspirator, reattach it to the cannula and resume the aspiration.

*Note:* Many clinicians keep a second prepared aspirator on hand during the procedure and switch aspirators if one becomes full.

#### *Cannula is withdrawn prematurely*

If the aperture of the cannula is accidentally withdrawn from the uterus beyond the external os, remove the cannula, taking care not to contaminate it through contact with the vaginal walls or other non-sterile surfaces:

- Detach the aspirator from the cannula, empty the aspirator, then re-establish vacuum.
- Reinsert the cannula if it has not been contaminated. If contamination has occurred, insert another sterile or HLD cannula.
- Reconnect the aspirator, release the vacuum and continue aspiration.

#### *Cannula is clogged*

If the cannula becomes clogged, a lack of tissue or bubbles flowing into the aspirator will be noted:

- Ease the cannula back toward, but not through, the cervical os. This movement will often unclog the cannula.

If this does not unclog the cannula:

- Depress the valve buttons and remove the cannula from the uterus, taking care to prevent contamination.
- Remove tissue from the opening in the cannula using sterile or HLD forceps.
- Reinsert the cannula using no-touch technique.
- Reattach the aspirator and continue the procedure.

**Caution:** Never try to unclog the cannula by pushing the plunger back into the cylinder.

### *Incorrect assembly*

If the aspirator does not seem to hold a vacuum at all, reassemble and test the vacuum of the instrument. Incorrect assembly is likely to cause loss of vacuum. (Please see Appendix G: Tips for using the Ipas MVA Plus and the Ipas MVA Instruments module.)

## 5.0 Post-procedure care

Post-procedure care includes all services provided after the medical procedures are complete but before a woman is released from the facility. It is necessary to ensure that any complications that occur before, during or immediately after medical care are identified and addressed. Post-procedure care provides an opportunity for the woman to obtain information about how to identify and seek treatment for complications that could arise after she has left the facility. It is also an excellent time to discuss and start contraception for women who choose it.



**Take vital signs**

### 5.1 Physical monitoring

Immediately after the uterine aspiration procedure has been completed, the woman's vital signs should be taken. She should then be allowed to rest and continue her recovery while being monitored until her baseline vital signs return. The length of the recovery period will vary depending on the woman's condition, the ease of the procedure, the types of pain medication administered and any other procedures performed. The purpose of monitoring is to:

- Ensure adequate recovery from the procedure as well as from perioperative medications;
- Detect and manage symptoms of post-procedure complications;
- Provide counseling and referral for other reproductive-health needs, including contraceptive counseling and services;
- Provide information about what to expect and what to do following discharge from the facility.

While the woman is recovering, the provider should closely monitor her physiological status, including vital signs, in accordance with facility protocols. The provider should evaluate the woman's bleeding at least twice before she is discharged to confirm that bleeding and cramping have decreased. Methods include asking the woman to describe her bleeding, looking for blood on her clothes and assessing her appearance. Women who are experiencing excessive blood loss may appear pale and increasingly weak, possibly with diminished

consciousness and abdominal pain. They may have a drop in blood pressure or increase in heart rate. Prolonged, severe cramping and excessive bleeding are not normal.

If any of the following symptoms are observed during the post-procedure period, the woman will either need to receive, or be referred for, immediate medical treatment:

- *Significant physical decline as reflected in vital signs or physiological status*
- *Dizziness, shortness of breath or fainting:* These symptoms may be caused by internal or external blood loss or a transient vasovagal reaction.
- *Severe vaginal bleeding:* While some post-procedure bleeding is expected, the amount of bleeding should decrease over time. Excessive bleeding may be a sign of an incomplete abortion, lack of normal uterine tone, cervical laceration or other complications.
- *Severe abdominal pain or cramps:* Some post-procedure cramping is normal, but the severity of cramping should decrease over time. Severe, prolonged cramping may be a sign of uterine perforation or hematometra, which is a pooling of blood in the uterus that can occur following uterine evacuation. Hematometra can present either immediately following the procedure or several days later. Signs of a hematometra include an enlarged, tender uterus. A woman who has a hematometra needs a repeat aspiration procedure.

## 5.2 Other physical health issues

If anemia is suspected or has been diagnosed, the provider should discuss dietary recommendations and nutritional supplements with the woman. Treatments for anemia include iron tablets and iron-rich foods such as green, leafy vegetables and red meat.

See Section 3.5 for information about post-procedure pain management.

## 5.3 Emotional monitoring and support

Staff who work with women during the post-procedure period should be trained to assess and respond sensitively to each woman's emotional state, and to monitor and provide care accordingly. A woman's emotional state affects the amount of pain she experiences and her rate of recovery. When a woman receives emotional support, she is better able to understand and accept her medical condition, recommended care and possible health outcomes.

Before discharge, the woman should be offered counseling support. The provider can refer her for other services, when appropriate, such as support services for women who have experienced violence. (Please see the Informed Consent, Information and Counseling module.)

## 5.4 Contraceptive counseling

Ideally, contraceptive counseling should be provided before the procedure (as described in Section 2.3) and women should choose their desired method. In the recovery area, make sure

that the woman knows how to use the method of contraception she has chosen and answer any of her questions. If she has not received contraceptive counseling before the procedure, it can be provided during the recovery period or prior to discharge. (Please see the Contraceptive Services module.)

## 5.5 Recovery and discharge

For most women, the in-facility recovery period will last 30 minutes to an hour. The post-sedation protocols of each facility will differ, but full recovery generally means that the woman is awake, alert and able to walk without assistance, has normal vital signs, and agrees that she feels ready to leave. In addition, she should be showing signs of normal recovery from the uterine evacuation and any other procedures—for example, slowed bleeding and decreased abdominal pain.

The woman may be discharged as soon as she is physiologically stable and has received all necessary information about her follow-up care.

A follow-up visit is not required following a routine uterine aspiration procedure. However, some women may desire follow-up for reassurance that the procedure was uncomplicated or to discuss contraception or other health issues. If a woman desires follow-up, providers can schedule a visit before she leaves the facility.

Prior to discharge, the woman should receive post-procedure counseling and information, including:

- Instructions for taking any prescribed medications;
- Information about resumption of sexual activity, return to fertility and contraception;
- Signs of a normal recovery;
- Signs and symptoms requiring immediate emergency attention (see box);
- Written or graphic instructions for obtaining emergency care, with 24-hour contact information and emergency phone numbers, if available;
- List of counseling and other services at the facility or in the community;
- Date, time and location of follow-up visit if desired.



### **Danger signs after uterine evacuation**

*Advise the woman to watch for signs and symptoms that require immediate medical care:*

- *Fever, chills, vomiting, fainting, severe pain, heavy bleeding (more than normal menstrual bleeding)*

*The following signs and symptoms should be monitored if they worsen rather than diminish over time:*

- *Prolonged cramping (more than a few days of abdominal pain, cramping or backache)*
- *Pain in the abdomen or distension of the abdomen*
- *Prolonged bleeding (more than two weeks of light bleeding)*
- *Odd or bad-smelling vaginal discharge*
- *Delay in resumption of menstrual periods (more than eight weeks)*
- *Dizziness*

*(Adapted from WHO 1995)*

Referrals for other reproductive and psychosocial needs are an essential part of postabortion care. Providers should ensure that when the woman leaves the facility she has all the information and referrals she needs to make informed choices about her health, fertility and care. (Please see Appendix D: Sample clinical referral form and the Informed Consent, Information and Counseling module.)

## 5.6 Discharge of women with complications

Women who experienced complications before, during or after postabortion care may need additional discharge instructions. Providers should place particular emphasis on the importance of follow-up care. It is essential that providers and facilities develop adequate protocols for following up with women who are at high risk for delayed complications or adverse sequelae.

Women who experience complications of MVA need clear, evidence-based explanations of the situation and should be included in decision making about their treatment options. Fears about complications, perhaps compounded by pain, can add to the emotional stress that may accompany the postabortion care process. Most women cope better with their situation when they receive accurate, thorough information and have the opportunity to ask questions and express their feelings.

(Please see Appendix E: Discharge information sheet and the Complications module.)

## 6.0 Follow-up care

Routine follow-up after an uncomplicated MVA procedure is not necessary. If there are complications, the woman should return to the facility immediately. If the woman desires follow-up care, an optional visit may be scheduled 1-2 weeks after the postabortion care visit.

If the woman returns for follow-up care, the provider should:

1. Confirm success of the uterine evacuation:
  - a. Ask how the woman has been feeling since the procedure, including her bleeding pattern and whether pregnancy symptoms have resolved or continued.
  - b. Conduct a physical examination.
2. If there is any doubt, the provider can conduct or refer for an ultrasound to look for a gestational sac or an ongoing pregnancy.
3. Stabilize, treat or refer for any acute problems and ensure that any earlier complications have been resolved.
4. Perform vacuum aspiration to complete the process in the case of a continuing incomplete abortion.
5. Inform the woman of what to expect following completion or continued treatment.
6. Review any laboratory tests results.



7. Provide a contraceptive method, if desired and not already provided.
8. Refer for other medical, gynecologic or counseling services where indicated.

Information for each of these steps can be found in this module as well as in the Clinical Assessment, Complications, Contraceptive Services and Informed Consent, Information and Counseling modules. For an example of useful forms, see Appendix D: Sample clinical referral form, Appendix E: Discharge information sheet and Appendix F: Sample follow-up visit medical form.

## **7.0 Special considerations: Young women**

Most aspects of providing postabortion care for young women are the same as for adult women, but there are some special considerations. This is likely a young woman's first pelvic exam, and she may be nervous or afraid. Therefore, providers should take special care to:

- Ensure that there is at least visual and preferably auditory privacy;
- Explain what they are doing at each step;
- Perform the examination as gently and smoothly as possible: If a range of specula sizes are available, use the size appropriate to the woman and conducive to the exam or procedure.

A nulliparous woman is more likely to have a tight cervix and thus probably requires a slower dilation process. Although women of all ages need pain management, the perception of pain and use of analgesia has been found to be higher on average in younger women than in older women.

## **8.0 Summary**

- PAC treatment can be an emergency situation, and the woman's condition can change quickly at any point during her care. The provider should remain alert for changes in the patient's emotions and physiology throughout the procedure, as these changes may indicate complications.
- Women who are unstable due to hemorrhage or sepsis need to be stabilized and treatment started immediately. Treatment may require immediate uterine evacuation.
- Cervical dilatation is required in some cases.
- Pain management should be provided without delay, including paracervical block, to address pain due to cervical manipulation. Providers should always offer gentle, respectful care and provide appropriate information, which can help women stay calm and reduce anxiety and pain.
- Before an MVA procedure, providers should perform a clinical assessment including physical examination, and if possible should counsel the woman and obtain informed

consent, and discuss her contraceptive needs. If unable to counsel before treatment, formal counseling should be offered during the recovery period.

- An assessment of uterine size and position must be completed before performing a uterine evacuation procedure. Providers should not attempt a uterine evacuation until the size has been determined.
- Prophylactic antibiotics should be administered prior to the procedure.
- Pain and discomfort during an MVA procedure can be reduced using a combination of verbal support, oral medications, paracervical block, gentle clinical technique and calming environment.
- Cervical dilatation can be performed by using mechanical dilators, progressively larger MVA cannulae, or misoprostol. Dilatation is not needed when the cervix allows a cannula of appropriate size to fit snugly through the os. In cases over 12-14 weeks, cervical preparation is recommended for all women.
- Signs that indicate the uterus is empty include: red or pink foam appears and no more tissue is seen passing through the cannula; a gritty sensation is felt as the cannula passes over the surface of the evacuated uterus; the uterus contracts around (grips) the cannula; the woman complains of or notes pain, indicating that the uterus is contracting.
- Evacuated tissue should be inspected for quantity and the presence of POC and signs of complete evacuation or molar pregnancy.
- No visible POC, a lower quantity of tissue than expected or an inconclusive tissue sample may indicate completed spontaneous abortion, continuing incomplete abortion, suspected ectopic pregnancy or anatomical anomaly.
- Instrument technical problems that can occur during an MVA procedure include a full aspirator, a cannula that is clogged or withdrawn prematurely, or a loss of vacuum due to incorrect assembly.
- The purpose of post-procedure monitoring is to ensure that the woman is recovering well, to detect and manage any complications, to offer counseling and referrals and to provide the woman with discharge instructions and information.
- Follow-up for a routine vacuum aspiration procedure is not necessary as long as she has good information about when to seek care for an emergency and has been provided with her chosen contraception. A woman may have follow-up if she would like reassurance that she is well after a procedure.
- Referral protocols and resource lists that provide simple, accurate and up-to-date information are essential components of an effective referral system.
- It is essential to provide information that can help the woman identify and seek attention for any danger signs that may appear after she has left the facility.
- Every woman should be offered contraceptive counseling and, if desired, a contraceptive method or referral before being discharged from the facility.

## References

### **Pain Management**

- Allen, R. H., Kumar, D., Fitzmaurice, G., Lifford, K. L., & Goldberg, A. B. (2006). Pain management of first-trimester surgical abortion: effects of selection of local anesthesia with and without lorazepam or intravenous sedation. *Contraception*, 74(5), 407-413. doi: 10.1016/j.contraception.2006.06.002
- Atrash, H. K., Cheek, T. G., & Hogue, C. J. (1988). Legal abortion mortality and general anesthesia. *American Journal of Obstetrics and Gynecology*, 158(2), 420-424.
- Bélanger, E., Melzack, R., & Lauzon, P. (1989). Pain of first-trimester abortion: a study of psychosocial and medical predictors. *Pain*, 36(3), 339-350.
- Castleman, L., & Mann, C. (2009). *Manual vacuum aspiration (MVA) for uterine evacuation: Pain management*. Retrieved from <http://www.ipas.org/en/Resources/Ipas%20Publications/Manual-vacuum-aspiration-for-uterine-evacuation--Pain-management.aspx>
- Dalton, V. K., & Castleman, L. (2002). Manual vacuum aspiration for treatment of early pregnancy loss. *Postgraduate Obstetrics & Gynecology*, 22(19), 1-6.
- De Oliveira, G. S., Agarwal, D., & Benzon, H. T. (2012). Perioperative single dose ketorolac to prevent postoperative pain: a meta-analysis of randomized trials. *Anesthesia & Analgesia*, 114(2), 424-433. doi: 10.1213/ANE.0b013e3182334d68
- Dean, G., Cardenas, L., Darney, P., & Goldberg, A. (2003). Acceptability of manual versus electric aspiration for first trimester abortion: a randomized trial. *Contraception*, 67(3), 201-206.
- Goodman, S., Wolfe, M., Hufbauer, E., Flaxman, G., Jackson, E., Kaminski, A., Nelson-Munson, K. (2012). *Early Abortion Training Workbook*, fourth edition. San Francisco, CA: UCSF Bixby Center for Global Reproductive Health.
- Mahomed, K., Healy, J., & Tandon, S. (1994). A comparison of manual vacuum aspiration (MVA) and sharp curettage in the management of incomplete abortion. *International Journal of Gynecology & Obstetrics*, 46(1), 27-32.
- Margolis, A., Leonard, A. H., & Yordy, L. (1993). Pain control for treatment of incomplete abortion with MVA. *Advances in Abortion Care*, 3(1).
- Renner, R. M., Jensen, J. T., Nichols, M. D., & Edelman, A. (2009). Pain control in first trimester surgical abortion. *Cochrane Database of Systematic Reviews*(2), CD006712. doi: 10.1002/14651858.CD006712.pub2
- Renner, R. M., Jensen, J. T., Nichols, M. D., & Edelman, A. B. (2010). Pain control in first-trimester surgical abortion: A systematic review of randomized controlled trials. *Contraception*, 81(5), 372-388. doi: 10.1016/j.contraception.2009.12.008
- Renner, R. M., Nichols, M. D., Jensen, J. T., Li, H., & Edelman, A. B. (2012). Paracervical block for pain control in first-trimester surgical abortion: A randomized controlled trial. *Obstetrics & Gynecology*, 119(5), 1030-1037. doi: 10.1097/AOG.0b013e318250b13e
- Romero, I., Turok, D., & Gilliam, M. (2008). A randomized trial of tramadol versus ibuprofen as an adjunct to pain control during vacuum aspiration abortion. *Contraception*, 77(1), 56-59. doi: 10.1016/j.contraception.2007.09.008
- Singh, R. H., Ghanem, K. G., Burke, A. E., Nichols, M. D., Rogers, K., & Blumenthal, P. D. (2008). Predictors and perception of pain in women undergoing first trimester surgical abortion. *Contraception*, 78(2), 155-161. doi: 10.1016/j.contraception.2008.03.011
- Smith, G. M., Stubblefield, P. G., Chirchirillo, L., & McCarthy, M. J. (1979). Pain of first-trimester abortion: its quantification and relations with other variables. *American Journal of Obstetrics and Gynecology*, 133(5), 489-498.

Suprpto, K., & Reed, S. (1984). Naproxen sodium for pain relief in first-trimester abortion. *American Journal of Obstetrics and Gynecology*, 150(8), 1000-1001.

Warriner, I. K., Meirik, O., Hoffman, M., Morroni, C., Harries, J., My Huong, N. T., et al. (2006). Rates of complication in first-trimester manual vacuum aspiration abortion done by doctors and mid-level providers in South Africa and Vietnam: a randomised controlled equivalence trial. *Lancet*, 368(9551), 1965-1972.

Wiebe, E., Podhradsky, L., & Dijak, V. (2003). The effect of lorazepam on pain and anxiety in abortion. *Contraception*, 67(3), 219-221.

Wiebe, E. R. (1992). Comparison of the efficacy of different local anesthetics and techniques of local anesthesia in therapeutic abortions. *American Journal of Obstetrics Gynecology*, 167(1), 131-134.

Wiebe, E. R., & Rawling, M. (1995). Pain control in abortion. *International Journal of Gynaecology and Obstetrics*, 50(1), 41-46.

Wiebe, E. R., Rawling, M., & Janssen, P. (1996). Comparison of 0.5% and 1.0% lidocaine for abortions. *International Journal of Gynaecology & Obstetrics*, 55(1), 71-72.

Wong, C. Y., Ng, E. H., Ngai, S. W., & Ho, P. C. (2002). A randomized, double blind, placebo-controlled study to investigate the use of conscious sedation in conjunction with paracervical block for reducing pain in termination of first trimester pregnancy by suction evacuation. *Human Reproduction*, 17(5), 1222-1225.

World Health Organization. (2012). *Safe abortion: Technical and policy guidance for health systems*. Geneva: World Health Organization.

### **MVA Procedure**

Baird, T. L., Gringle, R. E., & Greenslade, F. C. (1995). *MVA in the treatment of incomplete abortion: Clinical and programmatic experience*. Chapel Hill, NC: Ipas.

Castleman, L., & Blumenthal, P. (2009). *Spontaneous and induced abortion*. Philadelphia: American College of Physicians.

Dalton, V. K., & Castleman, L. (2002). Manual vacuum aspiration for treatment of early pregnancy loss. *Postgraduate Obstetrics & Gynecology*, 22(19), 1-6.

Johnson, B. R., Benson, J., & Hawkins, B. L. (1992). Reducing resource use and improving quality of care with MVA. *Advances in Abortion Care*, 2(2).

Kapp, N., Lohr, P. A., Ngo, T. D., & Hayes, J. L. (2010). Cervical preparation for first trimester surgical abortion. *Cochrane Database Syst Rev*(2), CD007207. doi: 10.1002/14651858.CD007207.pub2

Murphy, E. (1997). *Client-provider interactions (CPI) in family planning services: Guidance from research and program experience*. Washington, D.C.: PATH.

Policar, M. S., Pollack, A. E., Nicholas, C., & Dudley, S. (Eds.). (1999). *Principles of abortion care: A curriculum for physician assistants and advanced practice nurses*. Washington, DC: National Abortion Federation.

Winkler, J., Oliveras, E., & McIntosh, N. (Eds.). (1995). *Postabortion care: A reference manual for improving quality of care*. United States of America: Postabortion Care Consortium.

World Health Organization. (1994). *Clinical management of abortion complications: a practical guide*. Geneva: World Health Organization.

World Health Organization. (2007). *Managing complications in pregnancy and childbirth: A guide for midwives and doctors Integrated management of pregnancy and childbirth (IMPAC)*, Second edition. Geneva: World Health Organization.

World Health Organization. (2012). *Safe abortion: Technical and policy guidance for health systems*. Geneva: World Health Organization.

World Health Organization (WHO). (2003). *Managing complications in pregnancy and childbirth: A guide for midwives and doctors*. Geneva: World Health Organization (WHO).

World Health Organization (WHO), United Nations Population Fund, UNICEF, &The World Bank. (2006). *Pregnancy, childbirth, postpartum and newborn care: A guide for essential practice*. Geneva: World Health Organization (WHO).

Yellen, E., & Davis, G. C. (2001). Patient satisfaction in ambulatory surgery. *Association of Operating Room Nurses (AORN) Journal*, 74(4), 483-498.

#### **Post-Procedure Care**

Billings, D. L., & Benson, J. (2005). Postabortion care in Latin America: Policy and service recommendations from a decade of operations research. *Health Policy and Planning*, 20(3), 158-166. doi: 10.1093/heapol/czi020

World Health Organization. (1995). *Complications of abortion: Technical and managerial guidelines for prevention and treatment*.

World Health Organization. (2012). *Safe abortion: Technical and policy guidance for health systems*. Geneva: World Health Organization.

World Health Organization (WHO). (2003). *Managing complications in pregnancy and childbirth: A guide for midwives and doctors*. Geneva: World Health Organization (WHO).

#### **Follow-Up Care**

World Health Organization. (1995). *Complications of abortion: Technical and managerial guidelines for prevention and treatment*.

World Health Organization. (2012). *Safe abortion: Technical and policy guidance for health systems*. Geneva: World Health Organization

## Appendix A: Pharmacologic approaches to pain management during MVA

### *Pain medication*

Though the medications shown below are commonly used for pain management during uterine evacuation, many other options exist.

This table does not cover general anesthetic agents. Both anxiolytics and narcotics may cause respiratory depression, especially when they are used together. Accordingly, lower doses should be used when they are together than when they are separate. When medications are given intravenously immediately before a procedure they should be given slowly and intermittently by a specially trained provider. Problematic side effects can be avoided by repeated small intravenous doses that are titrated to a woman's level of pain and sedation. The peak analgesic effect should occur during the procedure to avoid excessive post-procedure sedation.

Even clinicians using lighter sedation analgesia must be able to manage respiratory arrest, in the unlikely event that an unintentional overdose should occur. Providers should be trained in airway management and cardiopulmonary resuscitation, and resuscitative equipment and appropriate antagonist drugs (naloxone and flumazenil) should be available.

Drug Type	Generic Drug Name	Dose and Timing	Half-life	Side Effects	Comments
NSAID	Ibuprofen	oral: 400 to 800mg one hour before the procedure	4-6 hours	Possible gastrointestinal upset	Do not use in women with active peptic ulcer disease or renal failure.
	Naproxen	oral: 550mg one hour before the procedure	4-6 hours	Possible gastrointestinal upset	Do not use in women with active peptic ulcer disease or renal failure.
	Ketorolac	oral: 20mg one hour before procedure IV: 30mg over at least 15 seconds 30 to 60 minutes before procedure IM: 60mg 30 to 60 minutes before procedure For women less than 50kg, all doses should be halved	4-6 hours		Single dose IM ketorolac prior to surgery may reduce opioid use and post-operative pain (de Oliveira 2012, Roche 2012). Do not use in women with active peptic ulcer disease, renal failure, breastfeeding or sensitivity to other NSAIDs. Breakthrough pain should be managed with narcotics rather than increasing ketorolac beyond the recommended doses.

Drug Type	Generic Drug Name	Dose and Timing	Half-life	Side Effects	Comments
<b>Analgesic</b>	Acetaminophen	oral: 500 to 1000mg 30 to 60 minutes before procedure	3-6 hours		Not a first-line pain medication for first trimester vacuum aspiration or EU with medical methods. May be used as an antipyretic. Liver toxicity from overdose (maximum dose = 4000mg/day) is a risk.
<b>Narcotic/ analgesic combination</b>	Acetaminophen 300mg + codeine 30mg	oral: 1-2 tablets one hour before procedure	3-6 hours	Drowsiness, light- headedness, nausea and vomiting, CNS and respiratory depression	If respiration is compromised, assist with breathing (airway management, oxygen and ambu bag) and reverse with naloxone (see below).  Be aware of combining with other acetaminophen containing products. Liver toxicity from overdose of acetaminophen (maximum dose = 4000mg/day).
<b>Narcotic/ analgesic combination</b>	Acetaminophen 500mg + hydrocodone 5mg	oral: 1-2 tablets one hour before procedure	4-6 hours	Drowsiness, light- headedness, nausea and vomiting, CNS and respiratory depression	If respiration is compromised, assist with breathing (airway management, oxygen and ambu bag) and reverse with naloxone (see below).  Be aware of combining with other acetaminophen containing products. Liver toxicity from overdose of acetaminophen (maximum dose = 4000mg/day).

Drug Type	Generic Drug Name	Dose and Timing	Half-life	Side Effects	Comments
Narcotic	Meperidine	oral: 100-150mg 30 to 60 minutes before procedure IV: 25-50mg 5-15 minutes prior to procedure IM/SC: 50-100mg 30 to 90 minutes prior to procedure	4-6 hours	Drowsiness, light-headedness, nausea and vomiting, CNS and respiratory depression, hypotension, seizures	If respiration is compromised, assist with breathing (airway management, oxygen and ambu bag) and reverse with naloxone (see below).  More rapid onset and shorter duration of action than morphine. Meperidine 60-80mg = morphine 10mg
	Fentanyl	IV: 50-100mcg immediately before procedure (may repeat every 10-15 minutes, not to exceed 250mcg) IM: 50-100mcg 30 to 60 minutes before procedure	30-60 minutes	Drowsiness, light-headedness, weakness, bradycardia, CNS and respiratory depression, hypotension, seizures	If respiration is compromised, assist with breathing (airway management, oxygen and ambu bag) and reverse with naloxone (see below).  More rapid onset and shorter duration of action than meperidine Fentanyl 100mcg = meperidine 75mg = morphine 10mg  Onset of action is 2-7 minutes when given IV.
	Tramadol	IV/IM: 50-100mg 15-30 minutes prior to procedure Oral/suppository: 50-100mg 60-90 minutes prior to procedure	4-6 hours	Drowsiness, light-headedness, weakness, sweating, fatigue, seizures	If respiration is compromised, assist with breathing (airway management, oxygen and ambu bag) and reverse with naloxone (see below). Less respiratory depression than morphine or meperidine  Tramadol 100mg = morphine 10mg



Drug Type	Generic Drug Name	Dose and Timing	Half-life	Side Effects	Comments
Anxiolytic Benzodiazepine	Diazepam	oral: 10mg one hour before procedure IV: 2-5mg IV 20 minutes before procedure	21-37 hours	Blurred vision, dizziness, disorientation, pain and redness on injection site, CNS and respiratory depression	If respiration is compromised, assist with breathing (airway management, oxygen and ambu bag) and reverse with flumazenil (see below).  Has a mild amnestic effect. Onset of action is 2-10 minutes when given IV.
	Midazolam	IV: 1-2mg immediately before the procedure then 0.5-1mg IV every five minutes as needed, not to exceed 5 mg  IM: 0.07-0.08mg/kg or about 5mg up to one hour before procedure	1-4 hours	Blurred vision, dizziness, disorientation, CNS and respiratory depression	If respiration is compromised, assist with breathing (airway management, oxygen and ambu bag) and reverse with flumazenil (see below). Midazolam 2.5mg = diazepam 10mg  Stronger amnestic effect than diazepam.  Onset of action is 1-5 minutes when given IV and 15-30 minutes when given IM.
	Lorazepam	oral: 1-2mg 30-60 minutes before procedure  IV: 2mg given over one minute before the procedure  IM: 0.05mg/kg up to a maximum of 4mg within 2 hours before the procedure	14 hours	Blurred vision, dizziness, disorientation, CNS and respiratory depression	If respiration is compromised, assist with breathing (airway management, oxygen and ambu bag) and reverse with flumazenil (see below).  Amnestic effect.  Occasionally may increase patient anxiety.
Reversal agent for narcotic	Naloxone	IV: 0.4mg vial mixed in 10mL saline. Give 1mL (40mcg/mL) every two minutes until reversal is seen			Naloxone's duration of action is one hour and may wear off before the narcotic. Therefore, patients treated with naloxone must be monitored closely for several hours.  Maintain airway and respirations while giving naloxone.

Drug Type	Generic Drug Name	Dose and Timing	Half-life	Side Effects	Comments
<b>Reversal agent for benzo-diazepine</b>	Flumazenil	IV: 0.2mg every minute until respirations return. Do not exceed 1mg.			Flumazenil's duration of action is one hour and may wear off before the benzodiazepine. Therefore, patients treated with flumazenil must be monitored closely for several hours. In the event of overdose with narcotic and benzodiazepine, reverse the narcotic first with naloxone and use flumazenil subsequently if needed. Maintain airway and respirations while giving naloxone.

## References

De Oliveira, G. S., Agarwal, D., & Benzon, H. T. (2012). Perioperative single dose ketorolac to prevent postoperative pain: A meta-analysis of randomized trials. *Anesthesia & Analgesia*, 114(2), 424-433.

Roche, N. E., Li, D., James, D., Fechner, A., & Tilak, V. (2011). The effect of perioperative ketorolac on pain control in pregnancy termination. *Contraception*. 85(3): 299-303.

## **Appendix B: Equipment and supplies for uterine evacuation procedure with Ipas MVA Plus**

- Personal protective barriers such as gloves, face protection
- Examination table with stirrups
- Strong light
- Ipas MVA Plus aspirator
- Lubricant for aspirator
- Selection of Ipas EasyGrip cannulae
- Speculum
- Tenaculum
- Small cup with sponge clamp and gauze
- Tapered mechanical dilators (Pratt or Denniston) or cannulae of increasing sizes
- 10 - 20cc syringe
- #20 - 23 gauge spinal or hypodermic needle or needle from IV insertion set
- Sponge stick with gauze
- Medium basin
- Smooth forceps
- Strainer
- Clear basin
- Betadine® or other non-alcohol based antiseptic
- Xylocaine 0.5% without epinephrine (for paracervical block)

## Appendix C: Cervical preparation before first-trimester vacuum aspiration

Cervical preparation is recommended before vacuum aspiration for all women over 12-14 weeks. Providers may offer cervical preparation before 12-14 weeks but do not need to use it routinely. In the first-trimester, women with cervical preparation have decreased procedure time and a decreased risk of incomplete abortion compared to women without cervical preparation. However, because first-trimester vacuum aspiration is so safe, it is not known whether cervical preparation decreases the risk of serious complications like injuries to the cervix and uterus.

Women experience side-effects from the medicine or dilators including increased pain, bleeding and nausea. Cervical preparation increases the complexity, cost and time needed to perform an abortion. These disadvantages must be weighed against the benefits of cervical preparation. For women at higher risk of complications (young women, nulliparous women, women with cervical abnormalities, or women at later gestational ages) or inexperienced providers, there may be a benefit from cervical preparation even before 12-14 weeks gestation.

The following table shows choices for cervical preparation. The choice depends on availability, expense, convenience and preference. If misoprostol is used, vaginal misoprostol has fewer systemic side-effects than sublingual misoprostol. Misoprostol should not be given more than three hours before an abortion as it increases the risk that a woman will expel her pregnancy before the procedure can occur.

Dose	Route	Timing
Misoprostol	400mcg vaginally	Three hours before the procedure
Misoprostol	400mcg sublingually	Two-to-three hours before the procedure
Mifepristone	200mg orally	24 to 48 hours before the procedure
Osmotic dilators	Placed in the cervix	6 to 24 hours before the procedure

## Appendix D: Sample clinical referral form

### *Referrals:*

The following form or one similar should be completed for any woman who is referred for care to another health-care facility. Because the form describes the woman's confidential medical information, including her history, the provider should ask her if she feels comfortable taking the form with her. If so, the woman should bring the form to the referral facility; if not, the provider should find an alternate means of ensuring that the referral facility receives the information.

Name and contact information of referral center or provider:

---



---

### *Client information:*

Name: \_\_\_\_\_

Age: \_\_\_\_\_

### **Reason for referral (include only pertinent medical history in "History" section below)**

Contraceptive services  Counseling  Screening/treatment for sexually transmitted infection

Screening for cancer  Violence support services  Other health or social services

(specify) \_\_\_\_\_

Treatment (include all pertinent information below)

Diagnosis:

---

History (reproductive history including number of pregnancies, births, etc):

Clinical condition (vital signs, findings of physical/pelvic examinations):

Initial treatment (fluids, drugs, procedures, any other medical steps taken):

Assessment of woman's condition/other information:

\_\_\_\_\_  
Health professional (print name)

\_\_\_\_\_  
Location (hospital, clinic)

\_\_\_\_\_  
Signature

\_\_\_\_\_  
Date

## Appendix E: Discharge information sheet

### *How to take care of yourself*

- Resume normal activities only when you feel comfortable doing so.
- Eat according to your normal customs and diet.
- Showering, tub bathing and swimming are permitted.
- Correctly and completely take the medications that you have been given:  
\_\_\_\_\_ is for pain and discomfort.

Take \_\_\_\_ pill(s) every \_\_\_\_ hour(s), as needed.

Other medications: \_\_\_\_\_

- Call the clinic (telephone number: \_\_\_\_\_) or come in before then if you have concerns.
- If you have received a contraceptive method, start using it *right away*. It is possible to become pregnant almost immediately after an abortion. If you did not receive a contraceptive method but would like to use one, see your provider as soon as possible. In the meantime, abstain from sexual intercourse or use condoms to prevent pregnancy.

### *What to avoid*

- Do not have sex until your contraceptive method has had a chance to take effect, if you wish to avoid becoming pregnant. Avoid using a vaginal sponge, diaphragm or cervical cap until all bleeding has stopped.
- Do not douche for one week after the procedure. Routine douching is not recommended unless prescribed by your clinician.

### *What is normal*

- Bleeding and cramping similar to a normal period for up to one week; spotting may occur for up to several weeks.
- Mild fatigue for a few days.
- There is no “normal” emotional reaction to an abortion procedure. Some women feel a sense of relief, while other women feel sad. If you experience strong emotions, it may help to talk with a trusted friend, relative or provider about these feelings.

### ***Seek care immediately if you experience any of these abnormal symptoms.***

What is abnormal?

- Fever
- Abdominal pain
- Nausea, vomiting
- Vaginal discharge that smells bad
- Dizziness, lightheadedness or fainting
- Severe cramping
- Bleeding that is much heavier than a normal period

*(Adapted from Engender Health, 2002b and Policar et al., 1999)*

## Appendix F: Sample follow-up visit medical form (if indicated)

Name \_\_\_\_\_

Date \_\_\_\_\_

Contact information \_\_\_\_\_

### ***Abortion using vacuum aspiration:***

Date of procedure \_\_\_\_\_ Name of provider and facility \_\_\_\_\_

### ***Medical abortion:***

Date of administration: mifepristone \_\_\_\_\_ misoprostol \_\_\_\_\_

### ***Interview***

Current bleeding?

Yes \_\_\_ No \_\_\_ Amount \_\_\_\_\_ Duration \_\_\_\_\_

Clots?

Yes \_\_\_ No \_\_\_ Size \_\_\_\_\_ Bright blood \_\_\_\_\_

Current pain/cramps?

Yes \_\_\_ No \_\_\_ Location \_\_\_\_\_ Mild \_\_\_\_\_ Moderate \_\_\_\_\_ Severe \_\_\_ Duration \_\_\_\_\_

Pain medication?

Yes \_\_\_ No \_\_\_ When \_\_\_\_\_ Relief \_\_\_\_\_

Fever?

Yes \_\_\_ No \_\_\_ When \_\_\_\_\_ How long \_\_\_\_\_ Highest temperature \_\_\_\_\_

Antibiotic prescribed? Yes \_\_\_ No \_\_\_

If so, antibiotic prescription completed?

Yes \_\_\_ No \_\_\_ If no, why not \_\_\_\_\_

Current contraception?

Yes \_\_\_ No \_\_\_ If yes, what type \_\_\_\_\_

If so, satisfied with method? Yes \_\_\_ No \_\_\_

Emotional status: How does the woman say she feels at this point?

\_\_\_\_\_  
\_\_\_\_\_

## Appendix F: Sample follow-up visit medical form *(continued)*

Uterus: size \_\_\_ weeks \_\_\_  
tenderness \_\_\_

Cervix: motion  
tenderness? Yes \_\_\_ No \_\_\_  
\_\_\_

Abdomen: soft/not  
tender? Yes \_\_\_ No \_\_\_

Adnexa: tenderness? Yes \_\_\_ No \_\_\_

Mass? Yes \_\_\_ No \_\_\_

Speculum exam done? Yes \_\_\_ No \_\_\_

Pulse \_\_\_\_\_ Temperature \_\_\_\_\_ Blood pressure \_\_\_\_\_  
Hgb/Hct \_\_\_\_\_ Other lab results \_\_\_\_\_

Comments:

\_\_\_\_\_  
\_\_\_\_\_

Plan:

\_\_\_\_\_

### ***Re-evacuation procedure (if applicable)***

Re-evacuation procedure notes:

\_\_\_\_\_  
\_\_\_\_\_

### ***Follow-up***

Medication ordered:

\_\_\_\_\_  
\_\_\_\_\_

### ***Referrals (if applicable)***

Reason and referring facility:

\_\_\_\_\_  
\_\_\_\_\_  
\_\_\_\_\_

*(Adapted from Hern, 1984 and Paul, 1999)*



## Appendix G: Tips for using the Ipas MVA Plus

### *Cap removal*

With one hand, press down on the cap release tabs; with the other hand, pull the cap off.

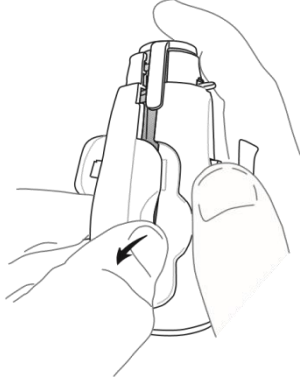

### *Opening the valve body*

Remove valve body from the cylinder. Place right thumb along side the right valve button and left thumb on the valve latch. With the left thumb, pull up and to the left on the valve latch while pushing down and out on the valve body with the right thumb.

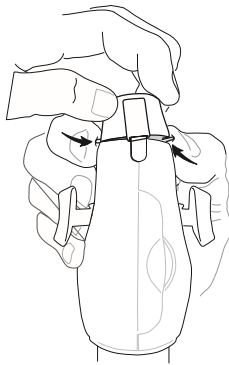

### *Aspirator assembly*

When assembling the aspirator, push the cylinder straight into the valve. Do not twist the barrel or valve when assembling as this will cause the liner to dislodge and may lead to device failure.

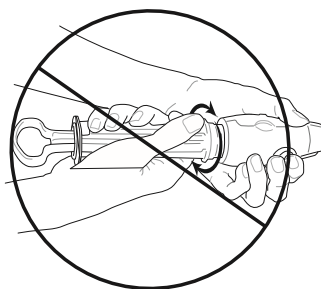
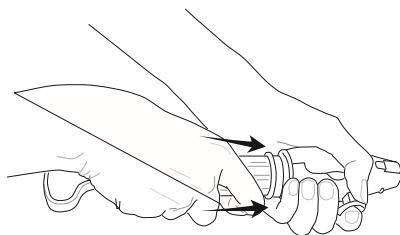

## Appendix G: Tips for using the Ipas MVA Plus (*continued*)

### *Removal and insertion of Ipas EasyGrip cannula*

If cannula removal is necessary during the procedure: Stabilize the cannula by grasping it at the base with one hand and holding it steady; with the other hand, hold the aspirator by the valve body, rotate the aspirator and gently separate it from the cannula. To insert the cannula, hold the aspirator by the valve body (not the cylinder), push cannula base in firmly, twisting slightly if necessary.

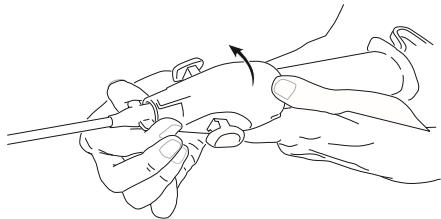

### *Reassembly of Ipas aspirators*

Place the valve liner in position inside the valve by aligning the internal ridges. Close the valve until it snaps in place. Snap the cap into place on the end of the valve.

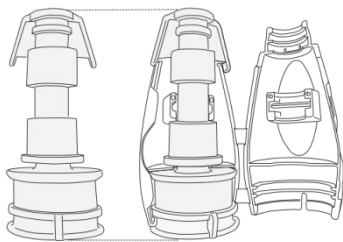

When processing the aspirator with liquid agents, make sure the parts are rinsed thoroughly in boiled/sterile water. When processing agents are allowed to dry on the devices, the plunger does not move easily in the cylinder. When chlorine is not rinsed sufficiently, it may also cause the valve hinges to wear prematurely.

When the cylinder becomes cloudy or pitted due to processing, soak the cylinder for a few minutes in vinegar, then clean the inside with a soft brush. Rinse in clean water.

Devices must be completely disassembled prior to cleaning. It is important to remove the O-ring from the plunger prior to cleaning and make sure lubricants are removed during cleaning.

## Appendix G: Tips for using the Ipas MVA Plus (*continued*)

### *Solving technical problems during the MVA procedure*

The most common technical problem seen with MVA instruments is loss of vacuum. In most MVA procedures, the aspirator vacuum remains constant until the aspirator is approximately 80 percent, or 50mL, full. However, a decrease in vacuum may occur before the aspiration is complete for the following reasons:

- The aspirator is full.
- The cannula is withdrawn past the external os.
- The cannula becomes clogged.
- Incorrect assembly.

If the aspirator fills up so that suction stops:

- Depress the buttons.
- Disconnect the aspirator from the cannula, leaving the cannula in place inside the uterus.
- Either empty the aspirator into a container by pressing the buttons and pushing the plunger into the cylinder or replace the aspirator.
- Re-establish vacuum in the aspirator, reattach it to the cannula and resume the aspiration.

*Note:* Many clinicians keep a second prepared aspirator on hand during the procedure and switch aspirators if one becomes full.

If the cannula becomes clogged, a lack of tissue or bubbles flowing into the aspirator will be noted:

- Ease the cannula back toward, but not through, the cervical os. This movement will often unclog the cannula.

If this does not unclog the cannula:

- Depress the valve buttons and remove the cannula from the uterus, taking care to prevent contamination.
- Remove tissue from the opening in the cannula using sterile or HLD forceps.
- Reinsert the cannula using no-touch technique.
- Reattach the aspirator and continue the procedure.

*Caution:* Never try to unclog the cannula by pushing the plunger back into the cylinder.

## **Appendix G: Tips for using the Ipas MVA Plus** *(continued)*

If the aperture of the cannula is accidentally withdrawn from the uterus beyond the external os, remove the cannula, taking care not to contaminate it through contact with the vaginal walls or other non-sterile surfaces:

- Detach the aspirator from the cannula, empty the aspirator, then re-establish vacuum.
- Reinsert the cannula if it has not been contaminated.
  - If contamination has occurred, insert another sterile or HLD cannula.
- Reconnect the aspirator, release the vacuum and continue aspiration.

Other reasons why the aspirator might not hold a vacuum are:

- Incorrect assembly
- A defective aspirator
- The need for a larger cannula to create a tighter seal in the cervix

# Uterine Evacuation with Misoprostol

## Key topics in this module:

- Eligibility requirements and contraindications
- Essential information for clients
- Regimens using misoprostol
- Expected effects, side effects and potential complications
- Pain-management approaches and medication regimens
- Post-procedure care and follow-up visit

## 1.0 Introduction

Misoprostol can be used for uterine evacuation for women with incomplete or missed abortion. This module focuses on misoprostol for incomplete abortion. It also includes information on misoprostol for missed abortion in Section 9.0.

Misoprostol stimulates uterine contractions and causes expulsion of uterine contents. It is inexpensive, stable at room temperature, easy to administer and available in many countries. For treatment of incomplete abortion, misoprostol can be used up to a uterine size of 13 weeks. When the recommended regimens are used, misoprostol for incomplete abortion successfully evacuates the uterus in more than 90 percent of cases.

## 2.0 Preparation

Before administering any medications:

- Provide counseling to the woman and obtain informed consent (Please see the Informed Consent, Information and Counseling module.)
- Perform a clinical assessment; including physical examination (Please see the Clinical Assessment module.)
- Discuss her contraceptive needs (Please see the Contraceptive Services module.)

### 2.1 Explaining the process to women

Before taking any medications, the woman should receive instructions about what she may experience, what pills to take, when and how to take them, when to follow up, and when and where to seek medical help in case of a problem. Because some words are probably unfamiliar to her (such as sublingual), providers should use simple language such as “under the tongue” and can use simple drawings to visually aid her in understanding how medications should be taken either at home or in the facility.

The provider should explain the expected effects and possible side effects of misoprostol, including pain, cramping and bleeding, and how she can manage her pain and any side effects - these are discussed in Sections 4.0 and 5.0. What is expelled will be different depending on the stage of the incomplete abortion. Most women will see only blood and clots, some of which may be large. Women may simply flush expelled products down the toilet or dispose of sanitary pads as they would after a normal menstrual period.

Thorough information on what the woman might expect helps her to be prepared. Reassurance and support during the uterine evacuation process, either by clinic staff or a person at home, can also be helpful.

### 2.2 Clinical assessment: Physical examination

Clinical assessment prior to misoprostol for incomplete abortion includes gestational dating, assessment of uterine size, assessment of the woman’s general health and any contraindications or precautions. (Please see the Clinical Assessment module.)

#### *Diagnose and accurately date the pregnancy*

Determine a woman’s gestational age based on her last menstrual period. Check uterine size by bimanual exam. Uterine size may be smaller than her stated gestational age because the pregnancy has stopped developing or she has passed all or some of the products of conception. Eligibility for misoprostol for incomplete abortion is based on uterine size. The regimens described here are for use up to 13 weeks uterine size.

#### *Eligibility, contraindications and precautions for misoprostol for incomplete abortion*

Eligibility:

- Open cervical os
- Vaginal bleeding or history of vaginal bleeding during the pregnancy

- Uterine size up to 13 weeks

Contraindications:

- Previous allergic reaction to misoprostol or other prostaglandin
- Known or suspected ectopic pregnancy
- Signs of pelvic infection and/or sepsis
- Hemodynamic instability or shock

Precautions:

- *IUD in place*: Evaluate for the presence of ectopic pregnancy. If none, remove the IUD
- *Severe/unstable health problems including but not limited to hemorrhagic disorders, heart disease, and severe anemia*: No evidence exists on the use of misoprostol in women with hemorrhagic disorder, heart disease, severe anemia and/or severe unstable health problems. Whether to provide misoprostol for uterine evacuation to women with these conditions will depend on the available options for referrals and clinical judgment. If misoprostol is given, it should be given under close observation.

Please see Appendix A: Clinical Flow Chart for a graphic of the process of clinical assessment and subsequent care using misoprostol for postabortion care.

## 2.3 Contraceptive needs

After uterine evacuation with misoprostol, a woman may have sex when she feels comfortable doing so. Because ovulation can occur almost immediately after a uterine evacuation, contraception should be provided immediately to women who want to prevent or delay pregnancy. All women who do not wish to become pregnant should leave the facility with an effective method of contraception.

If a woman desires long acting contraception or sterilization but it cannot be provided, an interim method should be given and referral made to the appropriate facility. In general, all modern contraceptive methods can be used immediately following first-trimester uterine evacuation with misoprostol provided that there are no contraindications. Contraception may be started with the administration of misoprostol. This recommendation is based on expert opinion. A woman's immediate need for reliable contraception after uterine evacuation, coupled with the risk that delayed contraceptive provision may reduce uptake, supports the recommendation to start these methods immediately.

IUDs may be inserted as soon as it is clear the process was successful. Delaying IUD insertion puts women at risk of unintended pregnancy, as rates of return visits may be low. Fertility awareness-based methods should only be used after a woman has had at least one postabortion menses and only if she had regular menstrual cycles prior to the uterine evacuation. (Please see the Contraceptive Services module.)

### 3.0 Recommended regimens

There are two regimens for use of misoprostol to treat incomplete abortion. They have similar safety and efficacy and have been shown in clinical studies to be effective at evacuating the uterus over 90 percent of the time. Success rates of misoprostol for incomplete abortion, like for medical abortion, increase with longer follow-up times. If a woman returns for follow-up after misoprostol and is still symptomatic, she may be offered vacuum aspiration. If she is stable, expectant management or a repeat dose of misoprostol may also be offered. The regimen for treatment of missed abortion is different from those for incomplete abortion. (Please see Section 9.0 for more information.)

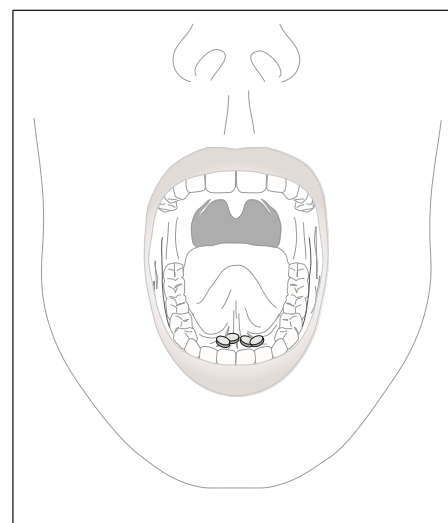

**Sublingual use of misoprostol**

The provider should give misoprostol only after the woman has received the following information:

- When and how to take the medication;
- What she should expect to feel and see in the uterine evacuation process;
- Warning signs and what to monitor as potential problems;
- Who to contact in case of questions or an emergency;
- Which pain-management drugs to take.

**Table 12-1: Misoprostol for incomplete abortion up to 13 weeks uterine size**

Dose	Route	Timing
Misoprostol 600mcg (three 200mcg pills)	Oral	Single dose
Misoprostol 400mcg (two 200mcg pills)	Sublingual	Single dose

### 3.1 Administration of misoprostol

There are two options for the route, dosage and timing of misoprostol administration. Sublingual or oral are recommended routes throughout the first trimester. See Table 12-1 above for dosage. Women should be given a choice of whether to remain at the health facility to take misoprostol or take it at another place.



### *Routes of Administration*

#### Oral use of misoprostol

- Swallow three pills (600mcg).

#### Sublingual use of misoprostol

- Place two pills (400mcg) under the tongue.
- After 30 minutes, swallow the remaining pill fragments.

### 3.2 Home administration of misoprostol

Misoprostol can be taken at home with high efficacy and low rates of complications if the woman is informed of potential side effects, how to handle them, and when to seek additional care. Many women prefer taking misoprostol at home with familiar surroundings, people and personal belongings. Doing this also can save them money in transportation costs as well as time. In turn, it saves the facility staff resources as well.

Staff should provide the following things to all women taking misoprostol at home:

- Misoprostol pills or a prescription for them;
- Detailed information on how to take the misoprostol;
- Pain medicine, such as ibuprofen and/or mild narcotics with instructions about how to take it;
- Written and pictorial information on the uterine evacuation with misoprostol process, side effects and warning signs, what signs indicate that the evacuation is complete, and information for follow-up contact, if desired;
- Information on whom to contact, including a telephone number where possible, in case of questions, problems or complications, or the possibility of an unsuccessful evacuation, and where to go in the case of an emergency;
- Other optional items: sanitary pads, cotton wool, contraceptive information and supplies.

Many clinics give this information and supplies in a take-home packet. It is also helpful to talk with each woman about her specific situation. For example, does she have a husband or support person who can be with her when she takes the misoprostol and after, when she is likely to begin bleeding? If she has children, has she arranged childcare in case she needs to rest? Does she have concerns about seeing and disposing of the tissue after it expels? A conversation about what to consider can help women to be most prepared.

### 3.3 Clinic administration of misoprostol

Whenever possible, women should be offered a choice of taking the misoprostol at home or in the clinic, as different women have different needs and desires. For some women, home may be a more private place but for others, the clinic may afford a greater degree of privacy.

After taking misoprostol, the woman may wait at the clinic for approximately 4 to 6 hours, depending on how long it takes the uterine contents to expel. A woman whose process has not completed within that time may remain longer waiting for expulsion, or she may return to her home if she has transportation and can seek follow-up care if necessary.

Clinics may have rooms with beds or curtained cubicles or, more commonly, a room that has several cots or reclining chairs and a toilet nearby. There should be enough toilet facilities to accommodate the maximum number of women receiving misoprostol at a given time. Women do not need to be restricted to beds but can move around the clinic if they prefer. Depending on space and the ability to ensure the confidentiality of all the women receiving services, facilities should also consider allowing each woman to have her husband or a support person with her during this time. A clinician or counselor should be available to answer questions and to address any medical concerns.

Staff should provide pain medication and hot-water bottles or warm cloths, if possible, to relieve discomfort from cramping. Expelled tissue does not need to be observed by a clinician to confirm a complete process.

If the woman leaves the clinic before uterine evacuation is complete, providers should:

- Give her instructions and supplies relevant to completing the process at home.
- Provide her with pain medication to take home.
- Review instructions and provide information on signs of a successful uterine evacuation with misoprostol, as well as warning signs of complications or an unsuccessful evacuation. Give her emergency contact information for the clinic.
- Provide a contraceptive method if desired.
- Inform her that she can return to the clinic anytime if she desires follow-up care. If she wants reassurance that the evacuation was successful, she should return after two weeks.

## 4.0 Expected effects

Once a woman takes misoprostol, the process may feel like an intense menstrual period or similar to a spontaneous miscarriage. The normal, expected effects — vaginal bleeding and cramping — should be distinguished from side effects of the medication or warning signs of true complications.

### 4.1 Pain and cramping

Most women will experience lower abdominal pain and cramping during a uterine evacuation with misoprostol, which may be stronger than that typically experienced during a menstrual period because contractions are needed to expel the uterine contents. Cramping usually begins within the first few hours after taking misoprostol. As the uterus contracts and its contents are expelled through the cervix, women generally feel some degree of cramping, which will soon diminish. Women's experience of pain is highly individual, which makes it impossible to predict how much pain a particular woman will experience. Young women, women who have never been pregnant, and women with painful periods may experience increased pain.

## 4.2 Pain management

Most women find pain related to uterine evacuation with misoprostol to be manageable, especially if they are prepared for the range of pain they might experience and take pain medicines as advised. Women should be provided with pain medication or a prescription at their first clinic visit.

The best regimen for pain control for uterine evacuation with misoprostol has not been established. In medical abortion-related research, NSAIDs have been found to be more effective than acetaminophen. If providers choose to use acetaminophen anyway, they should ensure the dose of acetaminophen does not exceed 4 grams in a 24-hour period to avoid liver toxicity. Ibuprofen can be given with misoprostol or once cramping starts. Narcotic analgesics are another option for pain control although the optimal drug, dose and timing are not known. One potential strategy is to provide women with NSAIDs and narcotic analgesics and advise them to begin with NSAIDs either with misoprostol or once cramping starts and alternate the two medications if she continues to experience pain.

In addition to medications, other methods that may help women manage pain during the process are thorough counseling, a supportive environment and applying a heating pad or hot water bottle to the lower abdomen. Music is effective for pain management during vacuum aspiration and may be helpful for uterine evacuation with misoprostol as well. These methods are complementary but not adequate substitutes for pain management with medications.

Providers should be aware that young women may be more susceptible to pain and may also have difficulty imagining the level of pain associated with the procedure. Providers should be able to give examples to compare pain to and take necessary measures to reduce pain and improve a young woman's experience.

(Please see Appendix A: Pharmacologic approaches to pain management during MVA in the uterine evacuation procedure with Ipas MVA Plus module.)

## 4.3 Vaginal bleeding

Vaginal bleeding, often accompanied by passage of clots, is usually heavier than a menstrual period but sometimes may be lighter. If she is not already bleeding, bleeding usually starts within one hour after taking misoprostol and tends to decrease after the uterine contents have been expelled. The average duration of bleeding is 5-8 days but may continue up to two weeks. Spotting may continue until the next menstrual period.

## 5.0 Potential side effects

The following side effects are associated with misoprostol use:

- Nausea
- Vomiting
- Diarrhea
- Fever, warmth or chills

- Headache
- Weakness
- Dizziness

Some of these symptoms may be related to the pregnancy itself rather than the medications. These pregnancy related symptoms can actually decrease after the process begins. Those symptoms that increase after taking misoprostol include temporary fever and diarrhea as well as nausea and vomiting.

Most of these side effects are mild and self-limited and can be treated at home. However, women who complain of prolonged or severe side effects that continue to occur 24 hours after the last dose of medications should be evaluated. (Please see the Complications module.)

## 6.0 Complications

Side effects and complications often happen on a continuum. For example, all women will experience bleeding, some women will experience prolonged bleeding that is an annoyance but is not harmful and very few women will experience heavy bleeding that requires further medical or surgical intervention. Actual complications are rare. For misoprostol for incomplete abortion, these include ongoing bleeding, hemorrhage and infection.

When counseling women before uterine evacuation with medical methods, it is important to give them information about how to tell the difference between a side effect that can be taken care of at home with supportive care and a complication that needs medical attention.

Women should contact their provider immediately if they experience:

- *Excessive bleeding*: Soaking more than two sanitary pads per hour for two consecutive hours, especially if accompanied by prolonged dizziness, lightheadedness and increasing fatigue;
- *Fever*: A temperature of 38°C (100.4°F) that occurs any day after the day misoprostol is taken;
- *Unusual or bad-smelling vaginal discharge*: Especially if accompanied by severe cramps or abdominal pain;
- *Severe abdominal pain*: Occurs any day after the day misoprostol is taken;
- *Feeling very sick*: With or without fever, and persistent severe nausea or vomiting after the day misoprostol is used.

Women who experience complications need clear, evidence-based explanations of the situation and should be included in decision making about their treatment options. Fears about complications, perhaps compounded by pain, can add to the emotional stress that may accompany the uterine evacuation process. Most women cope better with their

situation when they receive accurate, thorough information and have the opportunity to ask questions and express their feelings.

Although persistent side effects and serious complications are rare, clinic staff must be able to provide timely treatment or make appropriate referrals. If ultrasound is not routinely used in clinics that offer misoprostol for incomplete or missed abortion, a referral system for ultrasound services should be established to evaluate any questionable or troublesome cases that may occur. An alternative method, preferably vacuum aspiration, should be available on-site or through referral as back up for failed uterine evacuation with misoprostol.

(Please see the Complications module. Also see Appendix E: Discharge information sheet and Appendix D: Sample clinical referral form in the Uterine Evacuation Procedure with Ipas MVA Plus module.)

## 7.0 Instructions prior to leaving the clinic

Before leaving the clinic, the woman should receive instructions about what is normal for uterine evacuation with misoprostol, what pills to take, when and how to take them, when to follow up, and when and where to seek medical help in case of a problem. Because some words are probably unfamiliar to her (such as sublingual), providers should use simple language and can provide drawings to visually aid her in understanding how medications should be taken.

A pamphlet, card, or handout summarizing these points is often useful. A woman who is unable to read may still find it useful to take written instructions with her; she may have someone read it to her if she has questions. Pictorial resources for women who cannot read, such as illustrated guides outlining the misoprostol regimen, side effects, and possible complications, may be very helpful. (Please see Appendix B: Brochures for women for sample take-home instructional brochures on misoprostol for incomplete abortion.)

Information for women should include:

- Regimen and effectiveness
- What she will experience
- How long the process typically takes
- The signs of a successful uterine evacuation
- Expected effects, potential side effects and complications
- Warning signs to seek help
- Ensuring access to emergency care
- Contraceptive needs
- When and where to obtain follow-up care if necessary

In settings with telephones, contact information should be provided so the woman can call any time with questions or concerns. In some locations, a return to the health facility

may be the only way for the woman to access a clinician to assess her situation. Local referrals closer to a woman's home may be given in advance if the woman lives far from the clinic. Utilizing community health nurses or other community-based health workers or organizations can be a good source of local support and information for women, as long as they are well informed about medical methods and care. (Please see the Complications and Community Linkages modules.)

## 8.0 Follow-up care

A routine follow-up visit after misoprostol for incomplete abortion is usually not necessary. A woman who takes medication at home should be given an explanation of the symptoms she can expect. If a woman is concerned about ongoing bleeding or other problems, she may return at any time. If a woman desires reassurance after the process, she may return in approximately two weeks to confirm that the process was successful, or to receive additional desired services.

If the woman returns for follow-up care, the provider should:

1. Inquire about the woman's experience with the process.
2. Confirm success of the process:
  - a. Take a history of the process, amount and duration of bleeding, cramping and passage of clots;
  - b. Conduct a physical examination;
  - c. If there is any doubt, the provider can conduct or refer for an ultrasound to look for tissue in the uterus.
3. Perform vacuum aspiration to complete the process if uterine evacuation was not successful.
4. Inform the woman of what to expect following completion or continued treatment.
5. Review any laboratory tests results.
6. Provide a contraceptive method, if desired and not already provided.

(Please see the Complications module.)

## 9.0 Misoprostol for missed abortion or intrauterine fetal death

Although this module focuses on misoprostol for incomplete abortion, women may present with a pregnancy that is no longer developing but the pregnancy tissue remains in the uterus, also known as a missed abortion. This type of early pregnancy failure presents with little or no bleeding and a closed cervix and is often diagnosed with ultrasound. Women with missed abortion who have a uterine size up to 13 weeks and are clinically stable may be offered misoprostol, expectant management or vacuum aspiration.

A single dose of misoprostol 800mcg vaginally results in successful uterine evacuation in more than 80 percent of women. Some studies have used repeat doses of misoprostol 800mcg vaginally after 24 or 72 hours with a resulting increase in the complete abortion

rates. However, it is unclear whether the increase in complete abortion is due to the additional prostaglandin dose or the increased time to evaluation. When women are managed expectantly after a single dose of misoprostol, their complete abortion rates increase over time. Misoprostol 600mcg sublingually repeated every three hours for a maximum of two more doses achieves similar success rates.

Women using misoprostol for missed abortion should be assessed and treated similarly to women using misoprostol for incomplete abortion. However, they should be counseled that the success rates of misoprostol are lower for women with missed abortion and that more women may require vacuum aspiration to complete the uterine evacuation process.

**Table 12-2: Misoprostol for missed abortion or intrauterine death up to 13 weeks uterine size**

Dose	Route	Timing
800mcg	Vaginally	Single dose
600mcg	Sublingually	Every three hours for a maximum of three doses (1800mcg)

## 10.0 Summary

- Eligibility criteria for misoprostol for incomplete abortion are: open cervical os, vaginal bleeding or a history of vaginal bleeding during the pregnancy and uterine size less than thirteen weeks.
- Contraindications for uterine evacuation with misoprostol include:
  - Previous allergic reaction to misoprostol or other prostaglandin;
  - Known or suspected ectopic pregnancy;
  - Signs of pelvic infection and/or sepsis;
  - Hemodynamic instability or shock.
- Following misoprostol use, fertility returns quickly. Therefore if a woman wants to avoid pregnancy, contraception should be provided when she initially presents for postabortion care.
- Women receiving misoprostol for uterine evacuation are likely to experience pain, cramping and bleeding. They may experience side effects from misoprostol such as nausea or fever and chills. Providers should offer pain management to women using misoprostol.
- After misoprostol for incomplete abortion, bleeding will be similar to a woman's period and may continue for days.

- The dose of misoprostol for incomplete abortion is a single dose of 400mcg sublingually *or* 600mcg orally.
- The dose of misoprostol for missed abortion is a single dose of 800 mcg vaginally or 600 mcg sublingually every three hours for a maximum of three doses.
- If the initial dose fails and the woman is clinically stable, the misoprostol dose may be repeated. Other options include expectant management or provision of vacuum aspiration.
- Counseling includes the discussion of: basic information about uterine evacuation with misoprostol; risks and benefits, side effects and complications.
- Preparation prior to administering misoprostol includes: counseling and obtaining informed consent; performing a client assessment, including physical examination; confirming that the woman knows what to do if there is an emergency; and discussing her contraceptive needs.
- Before every physical examination or the administration of medication, it is important to make sure the woman knows what to expect and feels encouraged to express her concerns, questions and feelings.
- Thoroughly and accurately confirming the uterine size and ruling out ectopic pregnancy is key to safe, effective uterine evacuation with misoprostol.
- Appropriate facilities and staff support should be available to women who remain in the clinic during the process.
- Heavy vaginal bleeding and cramping are expected and normal components of uterine evacuation with misoprostol. Other side effects include nausea, diarrhea, vomiting, fever, warmth or chills, headache and dizziness.
- Both non-narcotic and narcotic analgesics can be used to treat pain associated with uterine evacuation with misoprostol.
- Although serious complications are rare, complications that can occur are remaining tissue in uterus, hemorrhage, infection and undiagnosed ectopic pregnancy.
- Before leaving the clinic, the woman should know the expected side effects of misoprostol she has taken or will take at home; the warning signs for potential complications; and when and where to seek medical help.



## References

- Avraham, S., Gat, I., Duvdevani, N. R., Haas, J., Frenkel, Y., & Seidman, D. S. (2012). Pre-emptive effect of ibuprofen versus placebo on pain relief and success rates of medical abortion: A double-blind, randomized, controlled study. *Fertility and Sterility*, 97(3), 612-615. doi: 10.1016/j.fertnstert.2011.12.041
- Bednarek, P. H., Creinin, M. D., Reeves, M. F., Cwiak, C., Espey, E., & Jensen, J. T. (2011). Immediate versus delayed IUD insertion after uterine aspiration. *New England Journal of Medicine*, 364(23), 2208-2217. doi: 10.1056/NEJMoa1011600
- Creinin, M. D., & Aubény, E. (1999). Medical abortion in early pregnancy. In M. Paul, E., S. Lichtenberg, L. Borgatta, D. A. Grimes & P. G. Stubblefield (Eds.), *A clinician's guide to medical and surgical abortion*. New York: Churchill Livingstone.
- Demetroulis, C., Saridogan, E., Kunde, D., & Naftalin, A. A. (2001). A prospective randomized control trial comparing medical and surgical treatment for early pregnancy failure. *Human Reproduction*, 16(2), 365-369.
- Faúndes, A., Fiala, C., Tang, O. S., & Velasco, A. (2007). Misoprostol for the termination of pregnancy up to 12 completed weeks of pregnancy. *International Journal of Gynaecology & Obstetrics*, 99 Suppl 2, S172-177. doi: 10.1016/j.ijgo.2007.09.006
- Gilles, J. M., Creinin, M. D., Barnhart, K., Westhoff, C., Frederick, M. M., & Zhang, J. (2004). A randomized trial of saline solution-moistened misoprostol versus dry misoprostol for first-trimester pregnancy failure. *American Journal Of Obstetrics And Gynecology*, 190(2), 389-394. doi: 10.1016/j.ajog.2003.08.024
- Goldberg, A. B., Greenberg, M. B., & Darney, P. D. (2001). Misoprostol and pregnancy. *New England Journal of Medicine*, 344(1), 38-47.
- Graziosi, G. C., Mol, B. W., Ankum, W. M., & Bruinse, H. W. (2004). Management of early pregnancy loss. *International Journal of Gynaecology And Obstetrics*, 86(3), 337-346. doi: 10.1016/j.ijgo.2004.04.038
- Gynuity Health Projects. (2009). *Misoprostol for treatment of incomplete abortion: An introductory guidebook*. New York, NY: Gynuity Health Projects.
- Honkanen, H., Piaggio, G., Herten, H., Bártfai, G., Erdenetungalag, R., Gemzell-Danielsson, K., Regulation, W. R. G. o. P.-O. M. f. F. (2004). WHO multinational study of three misoprostol regimens after mifepristone for early medical abortion. *BJOG*, 111(7), 715-725. doi: 10.1111/j.14710528.2004.00153.
- Ipas, & Venture Strategies Innovations (VSI). (2011). *Misoprostol use in postabortion care: A service delivery toolkit*. Chapel Hill, NC: Ipas.
- Lipscomb, G. H., Stovall, T. G., & Ling, F. W. (2000). Nonsurgical treatment of ectopic pregnancy. *New England Journal of Medicine*, 343(18), 1325-1329. doi: 10.1056/NEJM200011023431807
- Livshits, A., Machtiger, R., David, L. B., Spira, M., Moshe-Zahav, A., & Seidman, D. S. (2009). Ibuprofen and paracetamol for pain relief during medical abortion: a double-blind randomized controlled study. *Fertility and Sterility*, 91(5), 1877-1880. doi: 10.1016/j.fertnstert.2008.01.084
- Muffley, P. E., Stitely, M. L., & Gherman, R. B. (2002). Early intrauterine pregnancy failure: a randomized trial of medical versus surgical treatment. *American Journal Of Obstetrics and Gynecology*, 187(2), 321-325; discussion 325-326.
- Ngoc, N. T., Blum, J., Westheimer, E., Quan, T. T., & Winikoff, B. (2004). Medical treatment of missed abortion using misoprostol. *International Journal Of Gynaecology And Obstetrics*, 87(2), 138-142. doi: 10.1016/j.ijgo.2004.07.015
- Renner, R. M., Jensen, J. T., Nichols, M. D., & Edelman, A. (2009). Pain control in first trimester surgical abortion. *Cochrane Database of Systematic Reviews* (2), CD006712. doi: 10.1002/14651858.CD006712.pub2
- Stanek, A. M., Bednarek, P. H., Nichols, M. D., Jensen, J. T., & Edelman, A. B. (2009). Barriers associated with the failure to return for intrauterine device insertion following first-trimester abortion. *Contraception*, 79(3), 216-220. doi: 10.1016/j.contraception.2008.09.003

- Tang, O. S., Lau, W. N., Ng, E. H., Lee, S. W., & Ho, P. C. (2003). A prospective randomized study to compare the use of repeated doses of vaginal with sublingual misoprostol in the management of first trimester silent miscarriages. *Human Reproduction*, 18(1), 176-181.
- Tang, O. S., Ong, C. Y., Tse, K. Y., Ng, E. H., Lee, S. W., & Ho, P. C. (2006). A randomized trial to compare the use of sublingual misoprostol with or without an additional 1 week course for the management of first trimester silent miscarriage. *Human Reproduction*, 21(1), 189-192. doi: 10.1093/humrep/dei303
- World Health Organization. (2012). *Safe abortion: Technical and policy guidance for health systems*. Geneva: World Health Organization.
- World Health Organization (WHO). (2009). *Medical eligibility criteria for contraceptive use* (pp. 1 online resource (121 p.)). Retrieved from [http://whqlibdoc.who.int/publications/2010/9789241563888\\_eng.pdf](http://whqlibdoc.who.int/publications/2010/9789241563888_eng.pdf)
- Zhang, J., Gilles, J. M., Barnhart, K., Creinin, M. D., Westhoff, C., & Frederick, M. M. (2005). A comparison of medical management with misoprostol and surgical management for early pregnancy failure. *New England Journal of Medicine*, 353(8), 761-769. doi: 10.1056/NEJMoa044064

## Appendix A: Clinical flow chart

This clinical flow chart can be used to provide a general overview of the key components of postabortion care service provision.

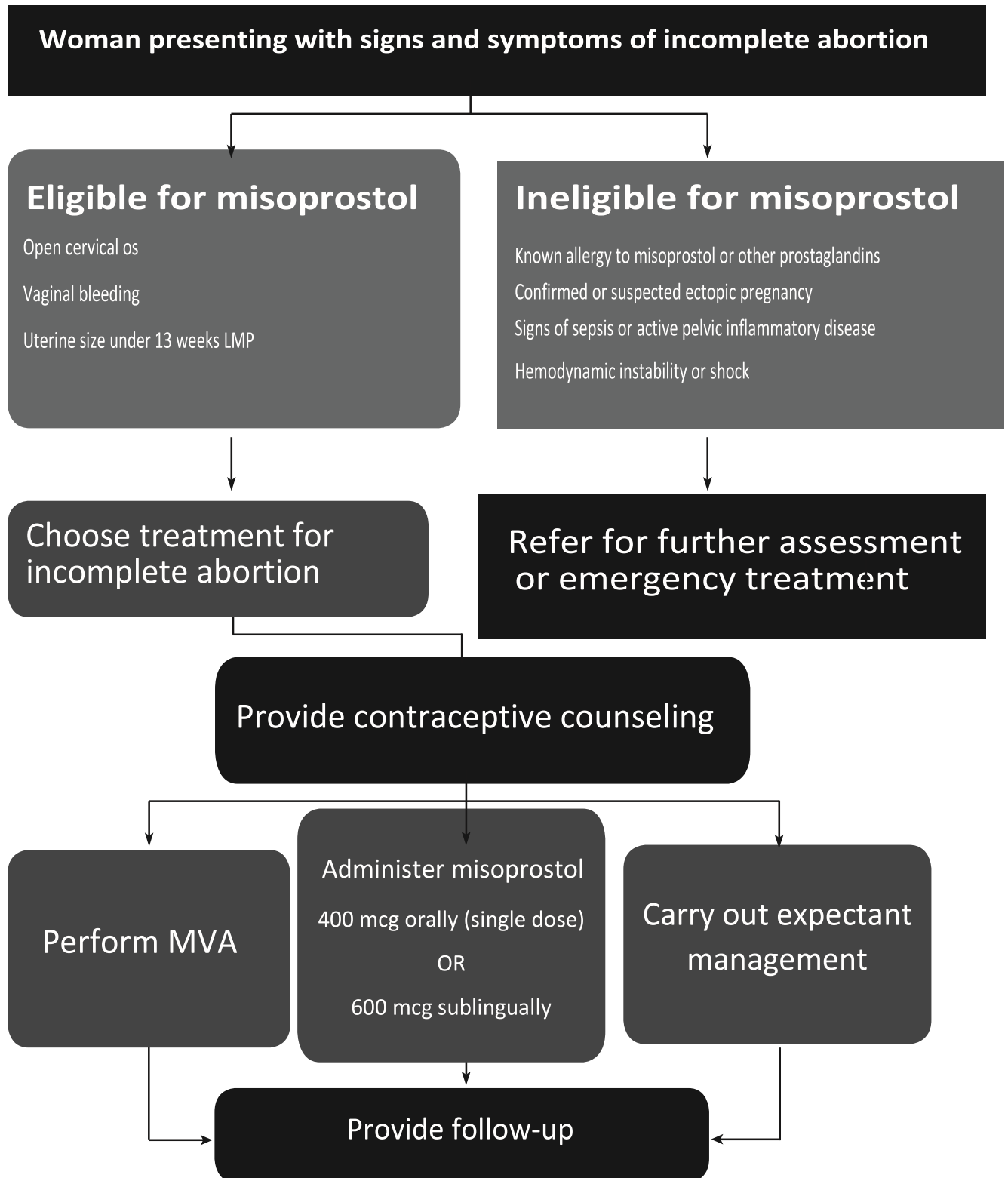

*Adapted from Ipas and Venture Strategies Innovations. 2011. Misoprostol use in postabortion care: A service delivery toolkit. Chapel Hill, NC: Ipas.*

## **Appendix B: Brochures for Women (FORTHCOMING)**

This tool is intended to be given by clinicians to women. It is recommended that facilities pick one route for misoprostol administration that they believe will be most acceptable to communities and easiest to administer.

# Complications

## Key topics in this module:

- Signs and symptoms of presenting, procedural and pregnancy-related complications
- Rapid initial assessment and management of shock
- Steps to diagnose, manage or refer complications
- Learning from adverse events

## 1.0 Introduction

Most women who present for postabortion care are stable and need routine management. Some women, however, may present in distress and need urgent treatment. Complications may occur during or after uterine evacuation. This module will focus on women presenting for postabortion care with severe complications, and their assessment, diagnosis and management.

Complications result from injury during the abortion procedure, incomplete uterine evacuation or infection. Often, because of healthcare barriers or stigma, women will delay seeking care after an unsafe abortion, which makes their condition worse. In the postabortion care setting, women may present with multiple complications that need emergency management.

When a woman has a life-threatening emergency, complete clinical assessment and voluntary informed consent may be deferred until actions have been taken to save the

woman's life. Once the woman is stabilized, the provider should make a complete clinical assessment and obtain her consent for continuing treatment.

Because emergency situations are often frightening or disturbing, women and their families who present with complications need emotional and psychological support. Providers should communicate openly with the woman about her condition and treatment.

## 2.0 Presenting complications

Typically, women presenting for postabortion care are ambulatory and complaining of vaginal bleeding and pain and fever or chills and need treatment for incomplete abortion. Women who have suffered more severe complications may present with shock, hemorrhage, sepsis and intra-abdominal injury. Severe complications are more likely in settings where unsafe abortion is common.

## 3.0 Procedural complications

When uterine evacuation is performed by a trained provider, procedural complications are infrequent. However, even in the most skilled hands, complications will occur. It is important to be prepared to diagnose complications and provide treatment quickly and safely. Complications can occur during uterine evacuation, during the recovery period or later, and facilities must have an established protocol to address this possibility. Complications may occur with vacuum aspiration and medical abortion. In most cases, complications can be managed successfully if treatment is initiated promptly. Serious complications are rare and can usually be treated by a trained clinician providing general emergency medical and surgical care. If emergency facilities are not available on site, complications should be managed through stabilization and the timely transfer of the woman to an acute-care facility.

## 4.0 Pregnancy-related complications

Some women may have pregnancy-related or gynecologic complications such as molar pregnancy, ectopic pregnancy or uterine abnormalities that require specific clinical consideration and management. These conditions are often discovered during the clinical assessment and can be addressed before the procedure is performed. Some may not become evident until during or after the uterine evacuation. (Please see the Clinical Assessment module and the Uterine Evacuation with Misoprostol module).

## 5.0 Rapid initial assessment and management of shock

The rapid, initial assessment should be performed on all women presenting for care. *Any member* of the facility staff can quickly check the **A**irway, **B**reathing, **C**irculation, and **C**onsciousness of the woman, as well as whether she has had or is having **C**onvulsions (the "ABC" signs) to identify if she needs urgent care. If a woman is severely ill, the staff member should call for help and activate emergency procedures. (For more information on the ABC signs assessment, see WHO's *IMAI District Clinician Manual: Hospital Care for Adolescents and Adults: Guidelines for the Management of Common Illnesses with Limited Resources*.)

Vital signs including temperature, blood pressure, heart rate and respiratory rate should be recorded. Signs and symptoms of shock should be assessed. (Please see Signs of Shock text box.) If a woman shows signs and symptoms of shock or has heavy vaginal bleeding, she needs immediate stabilization. (Please see Stabilization for Shock text box.) The initial stabilization steps should be taken *for all women* showing signs of shock or with heavy bleeding even if the cause is unknown.

Shock can develop in any patient at any time during postabortion care, especially if significant injuries were not initially detected. Therefore, it is important to be alert for signs of developing shock throughout the woman's treatment. Whenever signs of shock develop, health care workers should assess the stage and severity of shock immediately and take rapid action to keep her condition from worsening and save her life.

## 6.0 Secondary assessment for underlying causes of shock

Once the initial assessment and stabilization are underway, a more complete clinical assessment may be done to determine the cause and begin treatment. Shock in postabortion care clients is usually either hemorrhagic or septic. Hemorrhagic shock is the result of severe blood loss, which may be caused by an incomplete abortion, uterine atony or vaginal, cervical, uterine or intraabdominal injury. Septic shock is the end result of infection, which may come from incomplete abortion, endometritis or intra-abdominal injury. A history and directed physical exam with concurrent treatment should be done urgently for definitive management of underlying causes.

### 6.1 History

A history should be taken from the woman, if she is able to answer questions, or from any accompanying relatives or friends. Understanding her gestational age and what type of abortion services she may have obtained before coming to the facility can help guide diagnosis and management. (Please see the Clinical Assessment module.)

### Signs of shock

- *Low blood pressure (SBP <90mm HG)*
- *Fast pulse*
- *Pallor or cold extremities*
- *Decreased capillary refill*
- *Dizziness or inability to stand*
- *Low urine output (<30 ml per hour)*
- *Difficulty breathing*
- *Impaired consciousness, lethargy, agitation, confusion*

### Stabilization for shock

*If signs of shock or heavy bleeding:*

- *Ensure that airway is open. Turn her head to the side to prevent aspiration.*
- *Elevate the legs to increase return of blood to the heart.*
- *Give oxygen 5L/minute by mask or nasal cannula.*
- *Insert one or two large bore IVs, give 1-liter rapid bolus crystalloid (LR or NS) then reassess. Give second liter if vital signs remain abnormal.*
- *Transfuse if vital signs remain unstable after 2 liters IV fluid.*
- *Keep warm.*
- *Place urinary catheter.*
- *Monitor fluid intake and output including ongoing blood loss.*
- *Send laboratory evaluations including blood type and crossmatch, hematocrit and hemoglobin, blood cultures and chemistry tests if available.*
- *Monitor and record vital signs every 15 minutes.*

***Prepare for emergency transfer if woman cannot be treated in the facility.***

## 6.2 Physical exam

A physical exam should include vital signs, heart, lung, abdominal and pelvic exam. On abdominal exam, check for signs and symptoms of intra-abdominal injury including distension, rigidity, guarding and rebound. The pelvic exam should be done under optimal conditions with good positioning and lighting so that any bleeding can be identified and treated concurrently. Any instruments or anesthetics that may be needed should be prepared and available. Pain medication should be given to women who are uncomfortable or who may need a procedure to control bleeding.

On speculum exam, the vagina and cervix should be carefully inspected for any lacerations. Lacerations can be repaired during the examination with local anaesthesia. The cervical os should be inspected and any products of conception that are visible at the os removed with ring forceps. A bimanual exam should be performed and careful attention paid to the size and consistency of the uterus as well as any cervical motion tenderness or uterine tenderness. An enlarged boggy uterus could be a sign of incomplete abortion, infection or uterine atony and may indicate the need for uterine evacuation. Cervical motion tenderness or uterine tenderness indicates an infection or perforation.

## 7.0 Diagnosis and management of specific complications

A woman may have complications when she presents for postabortion care or a complication may occur during or after postabortion care at the facility. Whether complications occur before, during or after postabortion care, management is the same. Women may have and need treatment for more than one problem. Infection or sepsis commonly occurs with other complications. Shock management is integral to the management of all complications.

### 7.1 Incomplete abortion

After uterine evacuation, some tissue may remain in the uterus. Large amounts of retained tissue can result in heavy bleeding and infection if untreated. If a woman has heavy bleeding or signs and symptoms of infection, the recommended treatment is immediate vacuum aspiration.

#### *Signs and symptoms*

- Open os with products of conception and/or heavy bleeding;
- Enlarged uterus, with or without tenderness.

#### *Management*

- Manage shock as indicated (see Stabilization for Shock text box).
- Make sure the woman has adequate pain control, including paracervical block and oral or IV pain medication as needed if uterine aspiration is indicated.
- Give prophylactic or therapeutic antibiotics as indicated (please see the Clinical Assessment module).



- Provide uterine evacuation by one of these methods:
  - Vacuum aspiration if the woman has signs or symptoms of infection or has heavy bleeding or shock (please see the Uterine Evacuation Procedure with MVA Plus module).
  - Misoprostol if there are no contraindications (please see the Uterine Evacuation with Misoprostol module).
  - Close monitoring until the retained products are expelled if there are no contraindications. Small amounts of retained tissue may pass spontaneously without requiring further intervention.

### Uterotonics

*Therapies that may be given for bleeding or to stabilize a patient for transfer that have been used after vacuum aspiration or postpartum hemorrhage include:*

- *Methylergonovine 0.2mg intramuscularly or intracervically, repeat after 15 minutes for a maximum of 5 doses. Do not use in women with hypertension.*
- *Oxytocin 20 units in 1L IV at a rate of 60 drops per minute, maximum of 3L of fluid*
- *Misoprostol 200-800mcg orally, rectally or sublingually  
Intrauterine tamponade with sterile gauze packing, 30-75ml Foley balloon or inflated condom*

*These therapies may also be effective after a medical abortion.*

## 7.2 Cervical or vaginal lacerations

### *Signs and symptoms*

- Vaginal bleeding
- Lacerations are visible on speculum exam

### *Management*

- Make sure the woman has adequate pain control so the extent of the injury can be seen and the repair is adequate. Proper light and assistance is essential.
- For minor lacerations, apply pressure by clamping a ring forceps over the tear or apply silver nitrate.
- For lacerations requiring repair by suturing:
  - Apply local anesthetic to repair site; sedation may assist with ease of repair;
  - Ensure proper positioning and lighting;
  - Apply antiseptic solution to the cervix and vagina;
  - Grasp cervix gently with sponge or ring forceps;
  - Carefully inspect the entire cervix as there may be more than one laceration;
  - Starting at apex of tear, close tear with continuous absorbable suture. Use ring forceps to gently bring apex down if exposure is difficult;
  - Repair with laparotomy any tear that has extended deeply beyond vaginal vault or continues bleeding after suturing;
  - Vaginal packing may be used for emergent treatment of bleeding.

### 7.3 Uterine perforation with or without intra-abdominal injury

Uterine perforation can be life-threatening and prompt management is indicated because there is a high risk of infection and damage to other abdominal and pelvic organs (bowel, bladder and vessels). Bleeding may not be evident on pelvic exam but significant hemorrhage may be masked with intra-abdominal bleeding.

Rarely, perforation may happen during an aspiration procedure. The management depends on whether the aspiration procedure is complete, the size of the uterine injury and the presence of other intra-abdominal injuries.

#### *Signs and symptoms*

Presenting:

- Woman reports a history of abortion with instrumentation;
- Distended and/or rigid abdomen with rebound and/or guarding;
- Signs or symptoms of sepsis and/or shock.

During the aspiration procedure:

- Instruments pass further than the expected size of the uterine cavity;
- Fat or bowel noted in the aspirate;
- Aspirator vacuum decreases;
- Woman complains of severe abdominal pain during or after the procedure;
- Sudden increase in bleeding or pain.

#### *Management*

- Shock management as indicated (please see Stabilization for Shock text box);
- If the perforation occurred during the aspiration, the woman is stable, there are no signs of intra-abdominal injury and the evacuation is complete:
  - Admit woman and closely observe for signs and symptoms of intra-abdominal injury or hemorrhage. *This is appropriate only if the perforation occurred during the uterine aspiration and the provider feels confident that there were no other injuries;*
- If the woman is unstable and/or there are signs of intra-abdominal injury:
  - Laparotomy or laparoscopy to diagnose and manage intra-abdominal injuries;
  - If the facility cannot manage the complication, the woman should be stabilized and transferred to a higher-level facility;
- If evacuation is not complete:
  - Complete the evacuation under direct visualization (with laparotomy or laparoscopy);
  - If laparotomy or laparoscopy is not possible, prepare for transfer to a higher-level facility;

- Repair any damage during the laparotomy or laparoscopy. Inspect the abdominal cavity carefully for any small injuries;
- If the uterus or cervix is beyond repair or bleeding cannot be controlled, hysterectomy may be necessary.

## 7.4 Uterine atony

Uterine atony is a condition in which the uterus loses muscle tone and does not stop bleeding. Women with atony will bleed heavily. This complication is more common in women who have had several children or who are later in pregnancy. Atony may be secondary to incomplete abortion or intrauterine clots (hematometra).

### *Signs and symptoms*

- Enlarged, soft boggy uterus
- Heavy bleeding
- May be secondary to incomplete abortion

### *Management*

Management should be done step by step to control bleeding.

Providers should move quickly to the next step if bleeding is not controlled. Hysterectomy should be done only as a last resort.

- Conduct bimanual massage;
- Give uterotonic therapies (please see Uterotonics text box);
- Proceed with uterine aspiration;
- Perform intrauterine tamponade;
- Perform hysterectomy if bleeding cannot be stopped by other measures.

## 7.5 Intrauterine infection and sepsis

Infection may occur after a uterine evacuation procedure if the abortion was incomplete, infection prevention was not followed, or if a woman had a pelvic infection at the time of uterine evacuation. Intrauterine infection (endometritis) can become a more generalized infection (sepsis or septic shock) if it is untreated.

### *Signs and symptoms of intrauterine infection (endometritis)*

- Lower pelvic or abdominal pain

### **Broad spectrum antibiotics for intrauterine infection**

#### Oral Regimine

- **Ceftriaxone** 250 mg IM in a single dose PLUS
- **Doxycycline** 100 mg orally twice a day for 14 days WITH or WITHOUT Metronidazole 500 mg orally twice a day for 14 day

#### Parenteral (IV) regimen:

- **Cefotetan** 2 g IV every 12 hours OR
- **Cefoxitin** 2 g IV every 6 hours PLUS Doxycycline 100 mg orally or IV every 12 hours

**Note:** Additional antibiotic regimens may also be used, details at <http://www.cdc.gov/std/treatment/2010/pid.htm>

### **Broad spectrum antibiotics for sepsis:**

- **Ampicillin** 2g IV every six hours;
- PLUS Gentamicin 5 mg/kg body weight IV every 24 hours
- PLUS Metronidazole 500 mg IV every eight hours

- Fever and chills
- Uterine or lower abdominal tenderness on bimanual exam
- Cervical motion tenderness
- Unusual or bad smelling vaginal or cervical discharge

*Signs and symptoms of sepsis or septic shock*

- Suspected infection plus
- Hypotension (SBP <90mmHg) plus
- One or more of the following:
  - Pulse >100 per minute
  - Respiratory rate >24 breaths per minute
  - Abnormal temperature (<36C or >38C)

*Management of intrauterine infection (endometritis)*

- Provide shock management as indicated (please see Stabilization for Shock text box.)
- Begin broad spectrum antibiotics effective: against gonorrhea and chlamydia
  - Oral antibiotics may be used for mild to moderate cases;
  - Parenteral (IV) antibiotics for moderate to severe cases or women who are hospitalized or cannot tolerate oral regimens. 24-48 hours after clinical improvement is seen, the woman may be transitioned to oral antibiotics for a total course of 14 days.

*Management of sepsis or septic shock*

- Provide shock management as indicated (please see Stabilization for Shock text box);
- Begin broad-spectrum IV or IM antibiotics (please see Broad Spectrum Antibiotics text box):
  - Continue antibiotics until the woman is afebrile for 48 hours;
  - Switch to oral antibiotics for a total of at least seven days of treatment;
- If this was an unsafe abortion and vaccination history is unknown:
  - Administer tetanus toxoid and tetanus antitoxin;
- For women with incomplete abortion:
  - Conduct an immediate uterine evacuation;
- For women with suspected intra-abdominal injury:
  - Conduct laparotomy with injury repair;
- For women not responding to treatment:
  - A hysterectomy may be necessary.

**Tetanus**

*If an immunized woman has had an unsafe abortion, give her a booster injection of tetanus toxoid 0.5 mL IM. If she has not been immunized before, give her anti-tetanus serum 1500 units IM and a booster injection of tetanus toxoid 0.5 mL IM after four weeks.*

## 7.6 Hematometra

Hematometra is the accumulation of blood clots in the uterine cavity after aspiration. In such cases, the uterus cannot properly contract.

### *Signs and symptoms*

- Enlarged, firm, tender uterus after vacuum aspiration
- Pelvic pressure
- Intense cramps and pain
- Lightheadedness
- Mild fever
- Scant vaginal bleeding

### *Management*

- Re-aspiration

## 7.7 Vasovagal reaction

Vasovagal reaction is fainting as a result of vagal nerve stimulation during a procedure. A vasovagal reaction may occur when inserting an IV, drawing blood, giving medications or during the vacuum aspiration. In most cases, women will recover in less than a minute and will not require further treatment.

### *Diagnosis:*

- Lightheadedness or dizziness
- Sweating
- Fainting
- Low blood pressure
- Low pulse

### *Management*

- Lie the woman down and raise her legs up
- If prolonged, atropine 0.5mg IV

## 7.8 Persistent pain

A woman with intense, persistent pain after taking misoprostol should be evaluated for:

- Pregnancy tissue trapped in the os
- Ectopic pregnancy
- Upper reproductive tract infection

*Signs and symptoms*

- History of pain that persists for longer than 4-6 hours after taking misoprostol or intense pain unrelieved with ibuprofen and mild narcotics;
- Pregnancy tissue trapped in the os discovered during bimanual or speculum exam;
- Signs and symptoms of upper reproductive tract infection (see section 7.5 above);
- Signs and symptoms suggestive of ectopic pregnancy (see section 7.10 below).

*Management*

- If pregnancy tissue is trapped in the os:
  - Grasp with ring forceps and gently remove.
- If a woman has signs and symptoms of an infection, see section 7.5 above.
- If ectopic pregnancy is suspected, see section 7.10 below.

## 7.9 Allergic reactions

Allergic reactions to mifepristone and misoprostol are rare, but have been reported occasionally. A severe allergic reaction is very rare but can occur with any medicine, food or substance.

*Signs and symptoms*

- Swelling of the hands or feet
- Rashes
- Wheezing
- Sudden shortness of breath or swelling of the airway
- Any other severe or unusual reaction

*Management*

- Minor allergic reactions can be managed conventionally, for example with an antihistamine.
- Women with severe reactions should receive emergency treatment.

## 7.10 Ectopic pregnancy

All women presenting for postabortion care should be evaluated for the possibility of ectopic pregnancy (please see the Clinical Assessment). Neither vacuum aspiration nor misoprostol will end an ectopic pregnancy. For postabortion care, suspect ectopic pregnancy in a woman who presents with ongoing bleeding and abdominal pain even if she has had a previous uterine evacuation procedure. History of amenorrhea may or may not be present.

*Signs and symptoms*

- Persistent vaginal bleeding and pelvic pain;

- Minimal vaginal bleeding after taking medications for abortion;
- Uterine size smaller than expected;
- Sudden, intense and persistent lower abdominal pain or cramping, initially one-sided then generalized;
- Palpable adnexal mass;
- Fainting, shoulder pain, rapid heartbeat or lightheadedness due to ruptured ectopic with internal bleeding.

### *Management*

An ectopic pregnancy is a gynecologic emergency that can be life-threatening. Early diagnosis and treatment of ectopic pregnancy can save women's lives and help preserve their fertility.

- A ruptured ectopic pregnancy requires immediate surgical intervention;
- As soon as possible, treat a woman with a suspected ectopic pregnancy or transfer to a facility that can confirm the diagnosis and begin treatment.

## **8.0 Emergency response**

Urgent referral and transport of the patient may be necessary and clinic staff should be prepared to make the necessary arrangements 24 hours a day. Referral plans should be established at all health facilities. A written referral plan must be carefully constructed and should navigate the patient through the levels of hierarchy in care. Prompt communication and rapid transfer is essential within the facility and between facilities. (Please see Appendix A: sample clinical referral forms in the Uterine Evacuation Procedure with MVA Plus module.) Transporting patients immediately can save lives. Consider all locally available means and community resources, including police cars, church vehicles, health care-workers' cars, residents' cars and taxis.

Providers should be able to stabilize patients for transport by:

- Managing airway and breathing;
- Controlling bleeding;
- Providing intravenous fluid replacement;
- Controlling pain.

Emergency response plans may include:

### *On-call provider*

Ensure that a clinically knowledgeable person is available to answer women's questions and provide or refer for care 24 hours a day. This provider can triage those women who need reassurance or instructions versus those who need clinical assessment or emergency care. In the case of misoprostol for incomplete abortion, women may take the misoprostol at home and may need reassurance that the process is normal and should be over in a few hours, or they may have a problem that requires immediate medical attention.

### *Referral site relationship*

It is important to put in place referral agreements (such as a memorandum of understanding) about transferring a woman to the referral center if necessary; it is preferable to refer women to the most accessible site.

If possible, providers can establish a relationship with emergency room staff and gynecologists at their referral hospital. It can be helpful to provide an information session for the staff that serves as emergency referrals for women. The session could include an overview of PAC, the types of complications that may be seen, and how to triage a woman having a postabortion emergency. Invite hospital staff to the clinic providing uterine evacuation services.

### *Information sharing*

If a woman will be transferred to a referral hospital, providers will need to call the hospital to notify them that the woman is being transported, why she is being referred for care, her history, what measures have been taken in the clinic and her current condition.

Develop a mechanism to receive records or verbal reports of a woman who received emergency care at the hospital so that the clinic can stay informed of such cases and their outcome and provide appropriate follow-up care.

### *Practicing for emergencies*

On a routine basis, facility staff should review and practice how they will handle emergencies so that everyone knows their roles and protocols. Staff needs to practice how to do rapid initial assessment and diagnose and manage shock. Staff should review their emergency equipment and supplies including oxygen, intravenous fluids and medications.

### *Supplies*

Have an emergency cart or container with all the medicines and supplies that may be useful in an emergency. Have a regular monthly checklist of the contents of the cart to be sure it is stocked and that supplies and medications are not expired.

### *Links to communities*

Providers can work with community leaders and organizations, particularly women's and youth groups, to educate them about signs and symptoms of abortion complications that require prompt medical attention, as well as how and where women can receive emergency care. Communities can prevent delays in getting women with emergencies to health services such as through community-based emergency transportation systems. Health-facility staff can train community health workers or local health volunteers to refer women in emergency situations to health-care services, to follow up with women after care and to link women to contraceptive and other reproductive health services.



## 9.0 Post-procedure care

During post-procedure care for the patient with abortion complications, the woman must be:

- Physically monitored and emotionally supported with a focus on the individual medical needs determined by the nature of her complications;
- Advised about her condition, including use of medications and contraceptive methods, and any follow-up care needed;
- Counseled about any life changes as a result of the complications and their treatment (for example, post hysterectomy or bowel-perforation repair);
- Told what to expect and what to be concerned about, as well as what to do in an emergency situation and what not to do;
- Given written or illustrated materials about her condition.

(Please see the Informed Consent, Information and Counseling; Contraceptive Services; Uterine Evacuation with Ipas MVA Plus<sup>®</sup>; and Uterine Evacuation with Misoprostol modules.)

## 10.0 Serious adverse event monitoring

In the postabortion care setting, a woman may present with multiple complications that need treatment and/or emergency management. Unless these complications are the result of prior uterine evacuation services received at the facility where she has come for PAC treatment, these complications would not be considered *adverse events* for the treating facility.

By definition, adverse events are complications that a patient suffers during treatment that are not a result of her presenting condition. Adverse events are rare in routine postabortion and contraceptive care, but they do occur. Some adverse events cannot be anticipated (for example, allergic reaction to a medication) while others may be preventable (for example, an error in deciding dose of a medication). Some complications are minor and self-limiting (such as a cervical laceration that resolves after applying pressure), while others may be severe, resulting in life-threatening injury (such as bleeding that requires transfusion or surgical intervention) or death.

### 10.1 Types of adverse events

An **adverse Event (AE) / complication** is a problem requiring intervention or management beyond what is normally necessary that is related to a procedure or anesthesia.

A **serious adverse event (SAE)** results in death, life threatening injury, permanent impairment, or necessitates medical or surgical intervention to prevent permanent impairment.

A **near miss** is an event that has potential to harm a patient but does not because chance, prevention or mitigation.

Some examples of adverse events and serious adverse events are listed below.

Table 13-1: Examples of complications/serious adverse events (SAEs)	
Vacuum Aspiration	Medical Methods
Perforation treated conservatively or requiring surgery	Unplanned aspiration (for example, for heavy bleeding or pain)
Anesthesia related complication requiring hospitalization or causing seizures	Reactions to medications requiring emergency treatment
Bleeding requiring a blood transfusion	Bleeding requiring a blood transfusion
Infection requiring intravenous antibiotics and/or hospital admission	Infection requiring intravenous antibiotics and/or hospital admission
Unintended intra-abdominal surgery	Unintended intra-abdominal surgery
Ongoing pregnancy	Ongoing pregnancy
Ectopic pregnancy unrecognized at time of procedure	Ectopic pregnancy unrecognized when medical abortion given
Death	Death

## 10.2 Frequency of adverse events

It is estimated that one in every 10 patients in the hospital for any reason suffers some adverse event. Adverse events may be even more frequent in the developing world. Although postabortion care is extremely safe, even in the safest settings, adverse events can and will occur. The risk of death from safe postabortion care is extremely rare.

## 10.3 Why adverse events occur

Adverse events occur for many reasons. Adverse events are rarely the result of a single person or event, but usually result from a combination of multiple factors coming together during a single event.

Different factors leading to an adverse event are:

### *Client factors*

The client may not be able to communicate information or disclose other relevant medical problems or have high-risk medical conditions. In abortion-related care, we know that increasing gestational age increases the risk of adverse events. Therefore, a woman at 18

weeks is at higher risk than a woman at 10 weeks. Other factors that may make adverse events more likely are complex medical problems, obesity or altered uterine anatomy.

#### *Human error*

Human error comes in two forms: slips and lapses, and mistakes. Slips and lapses are when a plan of care is adequate but does not go as intended because of improper actions. This may be related to inattention, fatigue, or failure of memory. Mistakes are when the plan of care is improper for a certain situation. Most mistakes are due to problems with training, experience or knowledge.

#### *Institutional errors*

These errors occur when institutions do not adequately protect patient safety. For example, to save money an institution may not order the appropriate medications and supplies needed for treatment. A clinical setting that is not supportive may turn minor complication into a serious life-threatening event.

### 10.4 How to approach adverse events

After an adverse event has occurred and the patient has been cared for, there are two ways that events can be evaluated. The first way is in a culture of blame. In a **blame culture**, a hospital or clinic might look to see which person caused the error so that they can be made to take responsibility or be punished. The goal is not necessarily to improve care, but to focus on individual responsibility.

In a **safety culture**, open dialogue is encouraged by all the people involved in the adverse event including the providers, assistants, administrators, the patients and their family (if appropriate). When adverse events occur, facility staff can hold discussions with family and community members to prevent misunderstandings and even potential threats, while respecting the woman's privacy. In a safety culture, the goal is to see where the system failed and to improve the system so that in the future, the same adverse event does not happen again.

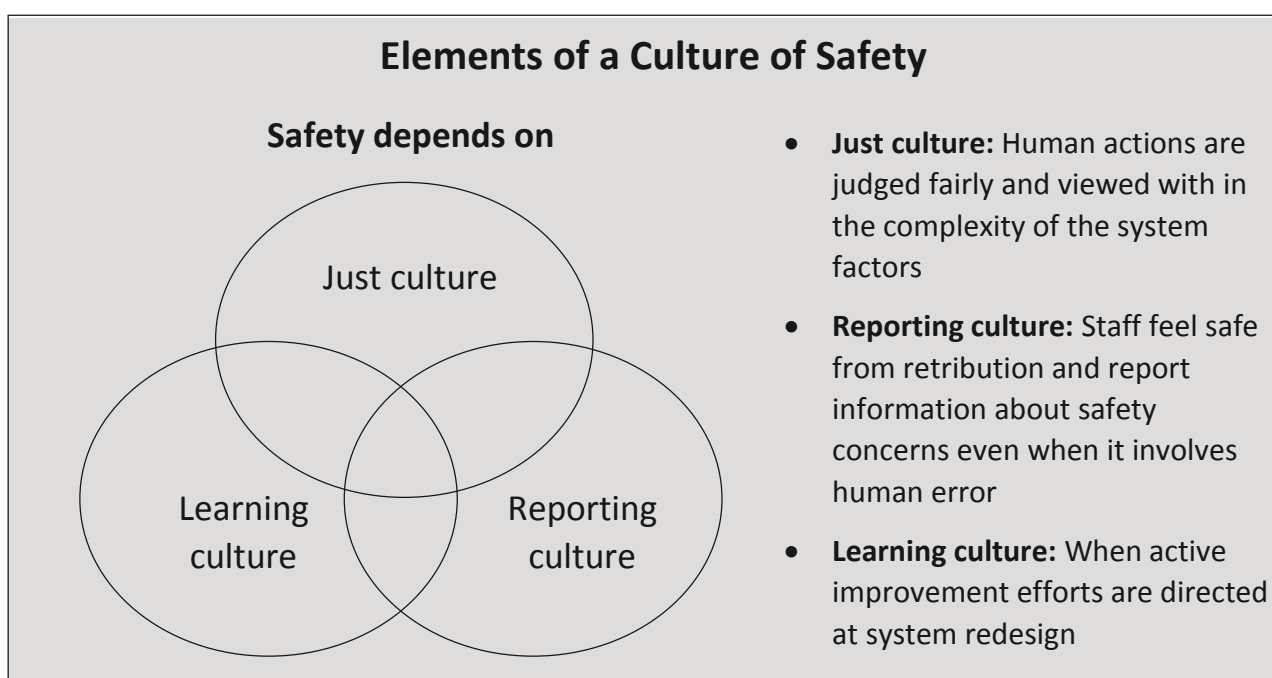

## 10.5 Adverse event reporting

Once an adverse event has been identified, and the woman has been cared for, it is important that the event is documented, reported and analyzed so that information learned can be used to improve care.

- *Record* all information required on the woman’s chart and the facility postabortion logbook.
- *Report* the adverse event to local authorities according to established guidelines.

## 10.6 Learning from adverse events

Learning from the adverse event is best accomplished through a team discussion with all relevant staff members. Conduct the meeting in the “spirit of learning” that is non-punitive and everyone is allowed and encouraged to speak.

As a team, discuss and answer these questions:

1. What happened?
2. Why did it happen?
3. What can be changed to prevent similar events in the future?

**Determine what could be changed to help prevent the adverse event from happening again, and implement that change.**

### Root cause analysis

*Root cause analysis is one of the ways of digging deeper into a problem to see where changes can be made to prevent an adverse event from happening in the future.*

*One technique of doing root cause analysis is called “The Multiple Whys.” With the multiple whys, you keep asking why an event occurred until you arrive at a problem where action can be taken.*

## 11.0 Summary

- Women may present for postabortion care with complications. In settings where unsafe abortion is common, complications may be multiple and severe.
- Women may also suffer complications during or after postabortion care.
- Women presenting for postabortion care need a rapid initial assessment.
- Shock is a life-threatening emergency that needs rapid diagnosis and management.
- While a woman is being stabilized, underlying complications must be diagnosed and managed to reverse the clinical course.
- Referral systems need to be in place if a facility does not have the capacity to manage severe complications.
- Although postabortion care is extremely safe, like with any medical procedure, adverse events can and will occur.
- Adverse events should be documented, reported and analyzed so that information learned can be used to improve care and client safety.

## References:

- Achilles, S. L., & Reeves, M. F. (2011). Prevention of infection after induced abortion: release date October 2010: SFP guideline 20102. *Contraception*, 83(4), 295-309. doi: 10.1016/j.contraception.2010.11.006
- Adler, N. E., David, H. P., Major, B. N., Roth, S. H., Russo, N. F., & Wyatt, G. E. (1990). Psychological responses after abortion. *Science*, 248(4951), 4144.
- American Psychological Association (APA) Task Force on Mental Health and Abortion*. (2008). Report of the APA Task Force on Mental Health and Abortion. Washington DC.
- Centers for Disease Control and Prevention (CDC). (2010). *STD Treatment Guidelines - 2010*. Retrieved from <http://www.cdc.gov/std/treatment/2010/default.htm>
- Chen, B. A., & Creinin, M.D. (2007). Contemporary management of early pregnancy failure. *Clinical Obstetrics and Gynecology*, 50(1), 67-88. doi: 10.1097/GRF.0b013e31802f1233
- Cleland, K., Creinin, M.D., Nucatola, D., Nshom, M., & Trussell, J. (2013). Significant adverse events and outcomes after medical abortion. *Obstetrics and Gynecology*, 121(1), 166-171. doi: <http://10.1097/AOG.0b013e3182755763>
- Copeland, L. J., Jarrell, J. F., & Dodson, R. (2000). *Textbook of gynecology* (Second ed.). Philadelphia: W. B. Saunders.
- Creinin, M.D., Schwartz, J. L., Guido, R. S., & Pymar, H. C. (2001). Early pregnancy failure—current management concepts. *Obstetrical and Gynecological Survey*, 56(2), 105-113.
- Hakim-Elahi, E., Tovell, H. M., & Burnhill, M. S. (1990). Complications of first-trimester abortion: a report of 170,000 cases. *Obstetrics and Gynecology*, 76(1), 129-135.
- Ipas. (2009). *Uterine evacuation with manual vacuum aspiration (MVA): A training manual for conducting short courses*. Chapel Hill, NC: Ipas.
- Ipas. (2013). *Woman-centered, comprehensive abortion care: Reference manual* (second ed.). K.L. Turner & A. Huber (Eds.). Chapel Hill, NC: Ipas.
- Kaunitz, A. M., Rovira, E. Z., Grimes, D. A., & Schulz, K. F. (1985). Abortions that fail. *Obstetrics and Gynecology*, 66(4), 533-537.
- Lichtenberg, E. S., & Grimes, D. A. (2009). Surgical complications: Prevention and management. In M. Paul, E. S. Lichtenberg, L. Borgatta, D. A. Grimes, P. G. Stubblefield & M. D. Creinin (Eds.), *Management of Unintended and Abnormal Pregnancy: Comprehensive Abortion Care* (pp. 224-251). West Sussex, UK: Wiley-Blackwell.
- March, C. M. (2011). Asherman's syndrome. *Seminars in Reproductive Medicine*, 29(2), 83-94. doi: 10.1055/s-0031-1272470
- National Cancer Institute. (2010). *Summary report: Early reproductive events and breast cancer workshop*, second edition.
- Practice, C. o. G. (2009, reaffirmed in 2011). ACOG Committee Opinion No. 434: induced abortion and breast cancer risk. *Obstetrics and Gynecology*, 113(6), 1417-1418. doi: 10.1097/AOG.0b013e3181ac067d
- Solter, C., Miller, S., & Gutierrez, M. (2000). Module 11: Manual Vacuum Aspiration (MVA) For Treatment of Incomplete Abortion *Comprehensive Reproductive Health and Family Planning Curriculum*. Watertown, MA: Pathfinder International.
- Thonneau, P., Fougeryrollas, B., Ducot, B., Boubilly, D., Dif, J., Lalande, M., & Soulat, C. (1998). Complications of abortion performed under local anesthesia. *European Journal Obstetrics Gynecology Reproductive Biology*, 81(1), 59-63.
- World Health Organization. (1994). *Clinical management of abortion complications: A practical guide*. Geneva: World Health Organization.
- World Health Organization. (1995). *Complications of abortion: Technical and managerial guidelines for prevention and treatment*. Geneva: World Health Organization.

World Health Organization. (2007). *Managing complications in pregnancy and childbirth: A guide for midwives and doctors*. Geneva: World Health Organization.

World Health Organization.(2009). World Health Organization’s guidelines for the management of postpartum haemorrhage and retained placenta. Geneva: World Health Organization.

World Health Organization. (2012a). *Safe abortion: Technical and policy guidance for health systems*. Geneva: World Health Organization.

World Health Organization.(2012b). World Health Organization’s recommendations for the prevention and treatment of postpartum hemorrhage. Geneva: World Health Organization.

World Health Organization (WHO). (2011). *IMAI district clinician manual: hospital care for adolescents and adults: guidelines for the management of common illnesses with limited resources* (Vol. 1). Geneva: World Health Organization (WHO).

# Glossary

**0.5% chlorine solution:** A chlorine (sodium hypochlorite) bleach solution that is used as a disinfectant for clinical equipment and instruments and for cleaning the environment; it inactivates some, but not all, microorganisms.

**Hematometra:** An accumulation of blood in the uterine cavity that occasionally occurs after a uterine evacuation procedure.

**Aseptic technique:** The combination of efforts made to prevent entry of microorganisms into any area of the body where they are likely to cause infection. Examples of aseptic technique are using antimicrobial cleansers on the skin or mucous membranes before a procedure and using a no-touch technique when handling instruments that will enter the uterus.

**Back-up method of contraception:** Any method of contraception that is used with another method of contraception in case the first method fails.

**Barrier methods:** Methods of contraception that prevent pregnancy by preventing the sperm from passing beyond the cervix. Some of these methods can also provide protection against certain sexually transmitted infections (STIs). Typical barrier methods include male and female condoms, diaphragms and dental dams.

**Coercive sex:** Includes all forms of sexual behavior that are engaged in through force, deception, cultural expectation, economic circumstances, and so on, and which the person was forced to perform against his or her will.

**Cognitive disabilities:** Cognitive disabilities include mental retardation and other developmental disabilities such as autism, severe and persistent mental illness, traumatic brain injury (TBI), stroke and Alzheimer's disease. Cognitive disability entails sub-average intellectual performance and limitations in adaptive behavior and can originate at any time.

**Complete clinical assessment:** Information taken by the health-care provider which includes physical examination of the client, review of the client's medical and surgical history, and laboratory and other diagnostic testing such as ultrasound, if needed.

**Contraceptive counseling:** Listening to a woman's needs and desires regarding pregnancy, and, if she wishes to delay or prevent pregnancy, explaining the proper use, risks and benefits of the available methods and helping her choose the methods that are best for her. Also known as family-planning counseling.

**Contraceptive services:** Contraceptive counseling and method provision. Also known as family-planning services.

**Contraindication:** If a woman has these specific conditions, under no circumstances should she be offered the contraindicated service or method. Alternatives should be considered or she should be referred to a facility where she can be offered alternate care.

**Emotional support:** Gentle, caring assistance to allay a person's fears or negative feelings. Emotional support can be physical, such as holding a person's hand, or verbal, such as using reassuring or encouraging words.

**Endospores:** Bacteria with a hard outer coating which are difficult to destroy.

**Environmental cleanliness:** Keeping the surroundings clean. Everything in a clinical setting, including patients, instruments and equipment, should be kept clean and dry; workers will be touching clinic surfaces and clients, which can spread infection.

**Family-planning services:** See contraceptive services

**Female genital cutting (FGC):** A term used to refer to any practice that includes the removal or the alteration of the female genitalia for cultural and other non-therapeutic reasons. Also known as female genital mutilation, female circumcision and, in some forms, infibulation.

**GATHER technique:** Used widely in family-planning counseling, this acronym stands for Greet, Ask, Tell, Help, Explain and Refer.

**Gender:** The socially constructed expectations, appearances, behaviors, roles, activities and attributes that a given society considers appropriate for men and women. These ideas and expectations often vary from culture to culture, over time, and are largely shaped by and indicative of societal values.

**High-level disinfection (HLD):** A process that inactivates most, but not all, disease-causing microorganisms on inanimate objects. High-level disinfection through boiling or the use of some chemicals inactivates all microorganisms except some bacterial endospores.

**Human chorionic gonadotropin (hCG):** A hormone produced early in pregnancy by the placenta; its detection in urine is the basis for one kind of pregnancy test.

**Human right:** Any basic right or freedom to which all human beings are entitled and in whose exercise a government may not interfere.

**Indicator:** A quantitative measure for monitoring or evaluating performance or achievement or to determine accountability. Indicators are also used to provide information about the quality of an activity, project or program.

**Infertility:** The diminished ability or the inability for a couple to conceive or bear children.



**Instrument processing:** The removal of microorganisms from instruments to make them safe for use on clients.

**Intrauterine device (IUD):** A contraceptive device that is inserted through the vagina into the uterus. Intrauterine devices are long acting, reversible and highly effective at preventing pregnancy.

**Intrauterine system (IUS):** An intrauterine device (IUD) that also releases hormones.

**Laparotomy:** An operation to open the abdomen.

**Lithotomy position:** The posture assumed by the client lying supine with the hips and the knees flexed and the thighs abducted and rotated externally; also called dorsosacral position.

**Male contraceptive methods:** Methods that men can use to prevent impregnating a woman such as condoms or sterilization.

**Microorganism:** An organism of microscopic or submicroscopic size, especially a bacterium or protozoan.

**Modern methods of contraception:** Contraceptive methods that are scientifically developed and proven to be sound and effective.

**Monitoring:** The routine tracking of health-care services in order to provide feedback for ongoing quality improvement.

**No-touch technique:** Aseptic technique used during a medical procedure that involves keeping processed instruments that will enter the body from touching any contaminated surface. In uterine evacuation, it means avoiding the vaginal walls when handling the intrauterine instruments used for the procedure.

**Nulliparous:** A woman who has never given birth.

**Pain management:** Using medicine, psychological support and other means to decrease a pain.

**Parity:** The classification of a woman by the number of live-born children as well as the number of stillbirths she has delivered at more than 20 weeks of gestation.

**Pathogen:** An agent that causes disease, especially a living microorganism such as a bacterium or fungus.

**Peer counseling:** Counseling performed by those who are considered equal to the person who is being counseled. For example, an adolescent who is seeking contraception may be counseled by another adolescent.

**Perineum:** In a woman, the area between the vulva and the anus.

**Personal protective barriers:** Gowns, gloves and face protection used to protect a health-care provider from germs and pathogens.

**Postabortion care (PAC):** A continuum of care to treat potentially life-threatening complications from incomplete and unsafe abortion and therefore reduce abortion-related morbidity and mortality. The five essential elements of PAC include: community and service provider partnerships, counseling, uterine evacuation treatment, contraceptive and family planning services and reproductive and other health services.

**Precaution:** If a woman has these specific conditions, the method has higher risks than normal. The risks, benefits and alternatives must be considered. Provision of the method may require a higher degree of clinical judgment, skill and monitoring. Referral to a higher-level facility may be appropriate.

**Quality of care:** Health-care services that are effective, efficient, accessible, acceptable, client-centered, equitable, safe and conform with accepted local standards, guidelines and practices.

**Reproductive goals:** The number of children one would like to have and the spacing of those children.

**Sexual health:** The health of one's physical reproductive system, as well as the ability to express sexuality in psychologically healthy ways.

**Sharps container:** Container that is specially designed to hold used sharps until they can be permanently discarded.

**Sharps:** Medical slang for needles or similar pointed objects that can penetrate skin.

**Steam sterilize/autoclave:** A chamber for sterilizing with steam under pressure. The original autoclave was essentially a pressure cooker.

**Sterilize:** To make free from live bacteria or other microorganisms.

**Teratogenic:** Able to disturb the growth or development of the fetus or embryo. Teratogens may lead to pregnancy loss (miscarriage) or birth defects in the child.

**Tools:** Materials, forms or other items that are utilized in conveying or collecting information or assessing or evaluating services.

**Standard precautions:** Infection-control measures—such as handwashing, use of personal protective barriers, environmental cleanliness, respiratory hygiene, preventing injury with sharps and correct instrument processing—that are designed to block transmission of potential infection. Standard precautions are an expansion of universal precautions to include practices that reduce the risk of infection in both health-care workers and among clients and visitors to health facilities.

**Unsafe abortion** is defined by the World Health Organization as a procedure for terminating an unintended pregnancy, carried out either by persons lacking the necessary skills or in an environment that does not conform to minimal medical standards, or both.

**Vagal reaction:** Also known as vasovagal syncope, it is a transient reaction marked by a drop in blood pressure and heart rate. Signs of a vagal reaction are pallor, nausea, sweating and loss of consciousness. A vagal reaction is often evoked by stress associated with fear or pain.

**Verbal support:** Caring, spoken encouragement to ease a person's fears or negative feelings.

**Violence against women:** Any act of gender-based violence that results in or is likely to result in, physical, sexual or mental harm or suffering to women, including threats of such acts, coercion or arbitrary deprivation of liberty, whether occurring in public or in private life.

